

Job Name: 23-1914 - KYTC Daviess County ID 231032
Job Location: Owensboro, KY 42701
Contractor: Mick-Murf Construction Inc.

PC: C. Goff
 TECH: J. Horsley
 Plant: 100



Structure ID: **063 (KY B 10ft)**
 Spec: KYTC
 Type: CBI TYPE B (10') private
 Size: 24" x 24"

Rim: 425.55'
 Invert: 418.82'
 Rim to Invert: 6.73'

Sump: 0"
 Floor (Top): 418.82'
 Floor Height: 8"

Floor (Bot): 418.153'
 Overall Height: 7.333'
 Slack: 0.76"

Structure Notes:

- ** KYTC STATE PROJECT ****
- PER KYTC CBI TYPE B / ASTM C913 SPEC'S.
 - CONCRETE = 4,000 PI AT 28 DAYS.
 - NO STEPS & NO INVERT CHANNEL.
 - CBI KY B F/G - BY OTHERS.
- REINFORCING PER ASTM A615 (GRADE 60).
 - TOP PHASE (As .62) #5 BARS AT 6" C.C.E.W.
 - WALLS (As .31) #5 BARS AT 12" C.C.E.W.
 - FLOOR (As .31) #5 BARS AT 12" C.C.E.W.

STRUCTURE SUMMARY:

P4) 8" x 120" - CB INLET KY B 10' TOP F/G - 9"	1660 lb
P3) 24" x 120" - CB INLET KY B 10' BOTTOM LEFT T/G - 17"	2650 lb
P2) 24" x 24" - FIELD ADJUSTMENT - 3"	0 lb
P1) 24" x 24" - BOX BASE 8inW, 8inF, Variable Ht F/n - 51"	4927 lb
2) 24" x 24" - Conseal CS-102 1.00"	0 lb
2) Hole - 22	0 lb
1) Hole - 6	0 lb
Structure Total:	9237 lb

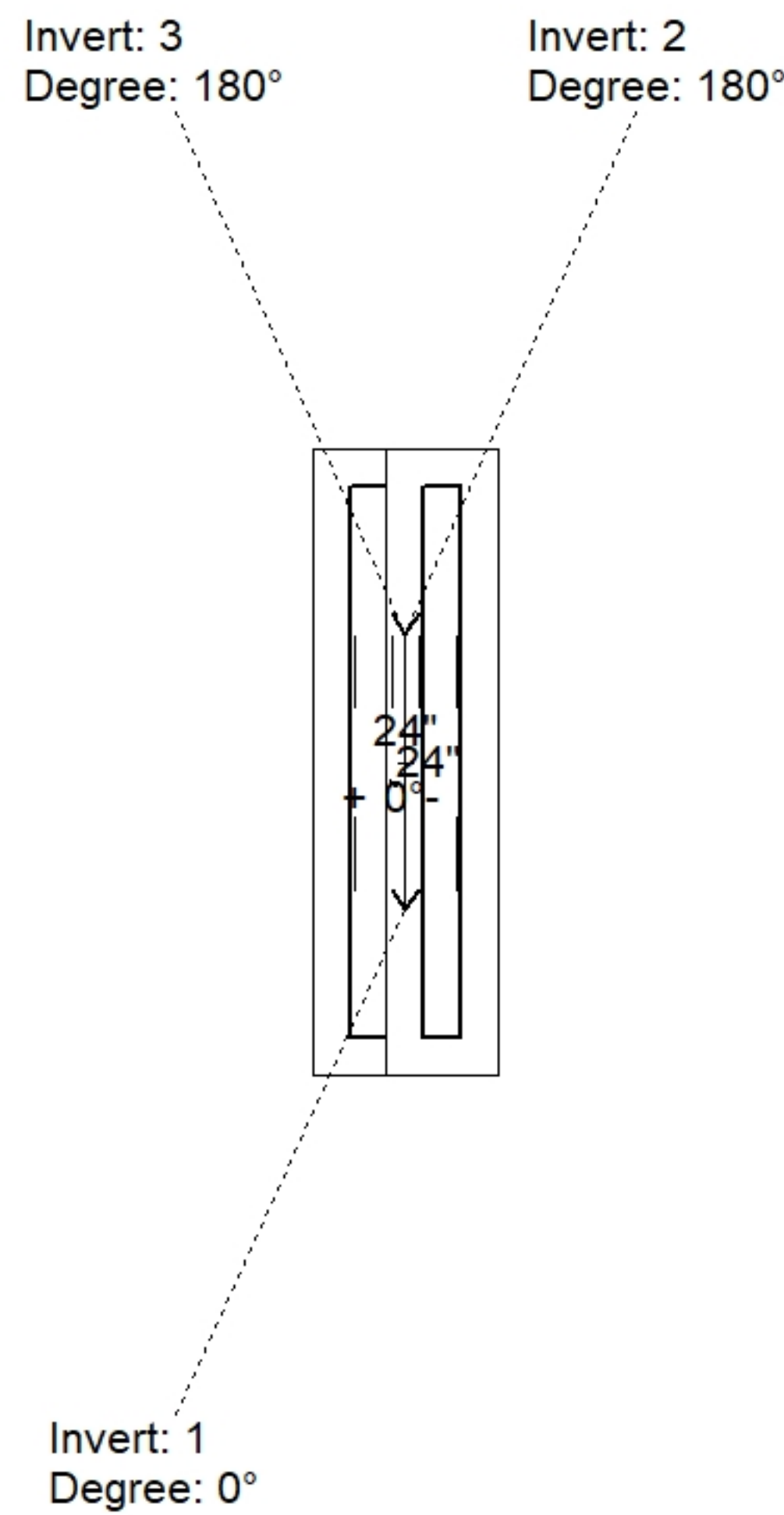

Position	Elev	Angle	Pipe	Pipe OD	Hole	Connector	Up ()	Ref
Rim	425.55'							
Reducer								
Invert 1	418.82'	0°	18" CMP	19"	22"	Hole 22	-0.5"	P1
Invert 2	418.91'	180°	18" CMP	19"	22"	Hole 22	0.625"	P1
Invert 3	422'	180°	4" HDPE (perf pipe)	4.8"	6"	Hole 6	37.75"	P1
Invert 4								
Invert 5								
Invert 6								
Invert 7								
Invert 8								

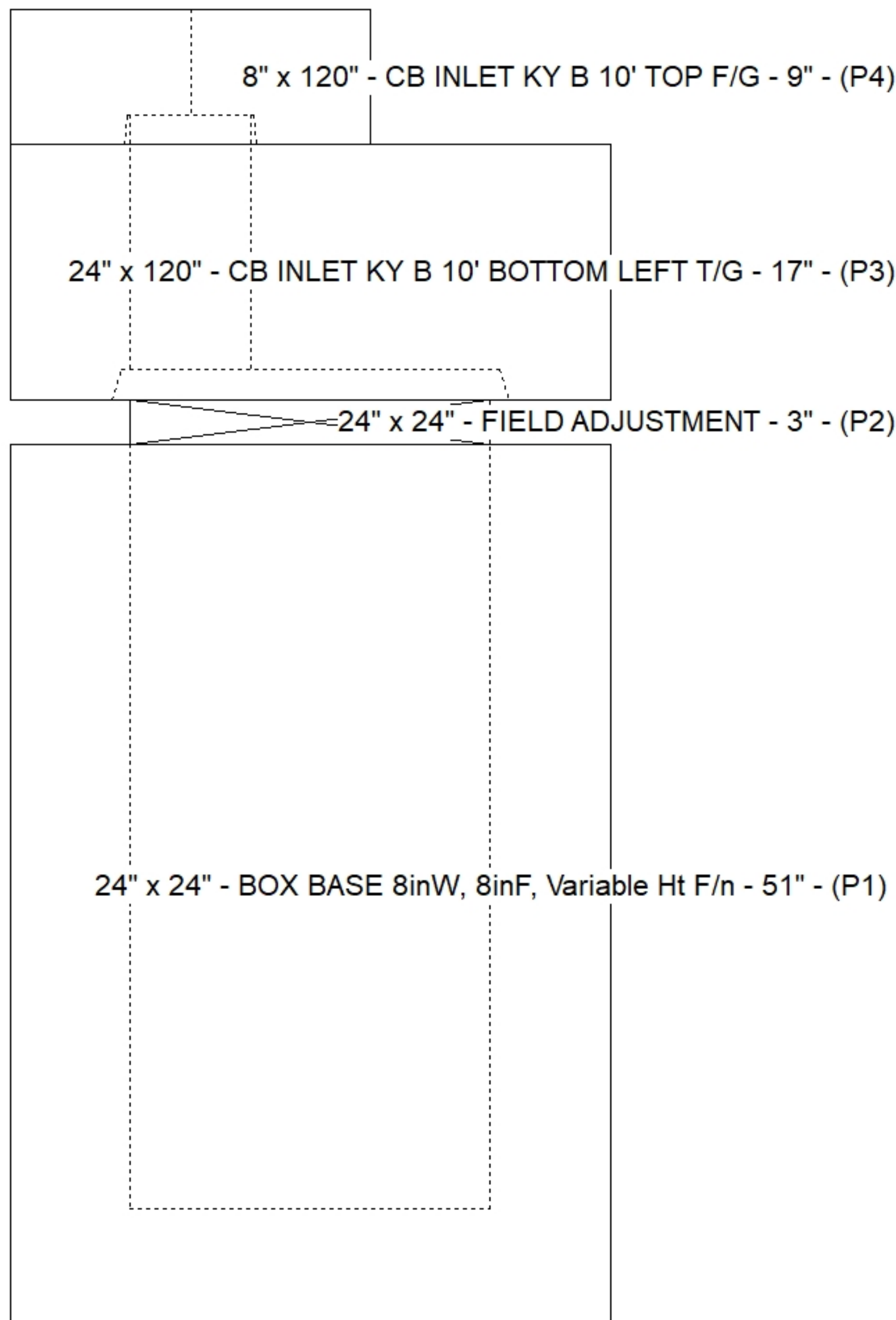

Cast (Int. Dim.) - Interior Dimensions

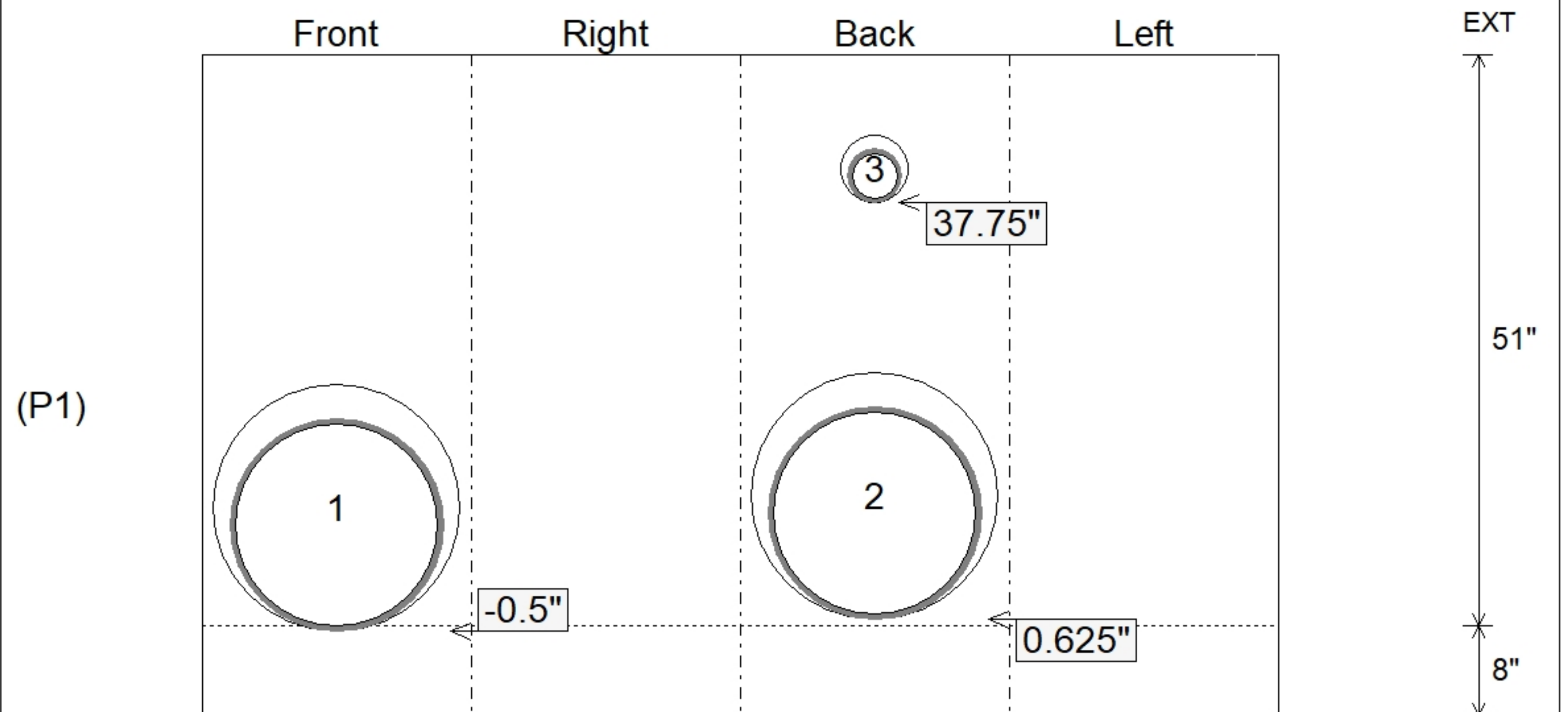

Submittal Drawing
 1/8/2026 10:13:11 AM

SUBMITTAL
 APPROVED BY: