

Structure ID: QL2
P2 MH036RS72

MH RISER T/G

P5) 24" - CASTING HEIGHT - 7" P4) 36" - MH FLAT TOP w/ 24" Ctr. Hole F/G - 10" P3) 36" - MH RISER Custom Ht T/G - 47" P2) 36" - MH RISER T/G - 72" P1) 36" - MH BASE T/n - 18" 1) JOINT WRAP - 0.065"x6"x50' CONSEAL CS212 1) JOINT WRAP PRIMER - CONSEAL CS-75 (1 gal.) 1) ASSEMBLY REQUIRED 1) CASTING - HOE MC-375 F/C Storm 3) 36" - Conseal CS-102 1.00" (Double) 2) Hole - 16	0 lb 896 lb 1982 lb 2898 lb 1525 lb 0 lb 0 lb 0 lb 271 lb 0 lb 0 lb ----- Structure Total: 7572 lb
-------------------------------------------------------------------------------------------------------------------------------------------------------------------------------------------------------------------------------------------------------------------------------------------------------------------------------------------------------------------------------------------------------------------	----------------------------------------------------------------------------------------------------------------------------------------

Structure Notes:
 1. PER ASTM C478 SPECIFICATIONS.
 2. CONCRETE = 4,000 PSI AT 28 DAYS.
 3. CASTING BY ICAST (HOE MC-375 F/C "STORM").

REINFORCING PER ASTM A615 (GRADE 60).
 - TOP SLAB (As .62) #5 BARS AT 6" C.C.E.W..
 - RISER/WALLS (As .12)
 - FLOOR (As .31) #5 BARS AT 12" C.C.E.W.

Rim: 679.22' Rim to Invert: 8.29' Slack: 0.44" Sump: 54.96" Step Position:

Position	Elev	Angle	Ext. (cw)	Pipe	Pipe OD	Connector	Hole	Horz Size	Up ()	Offset
Invert 1	670.93'	0°	0"	12" HDPE	14.5"	Hole 16	16"	16.58"	31.46"	0"
Invert 2	670.93'	62°	23.806"	12" HDPE	14.5"	Hole 16	16"	16.58"	31.46"	0"
Invert 3										
Invert 4										
Invert 5										
Invert 6										
Invert 7										
Invert 8										

RIGHT-SIDE UP VIEW (int. dimensions)

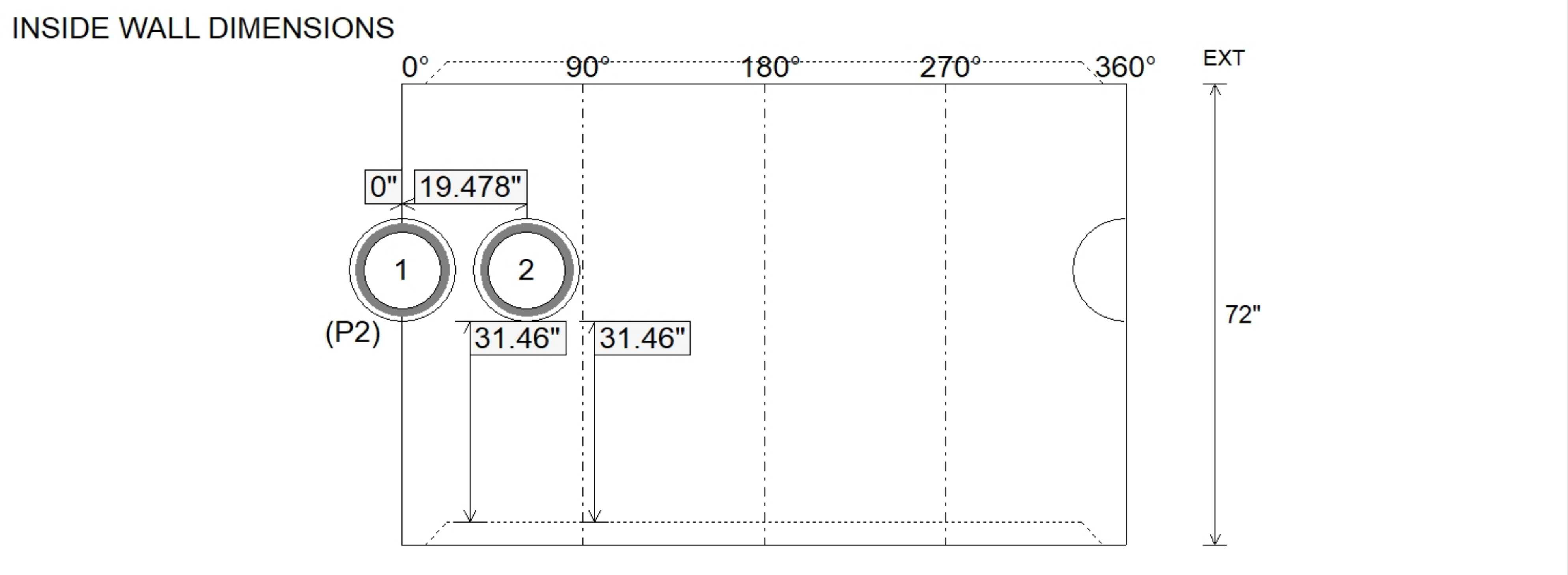
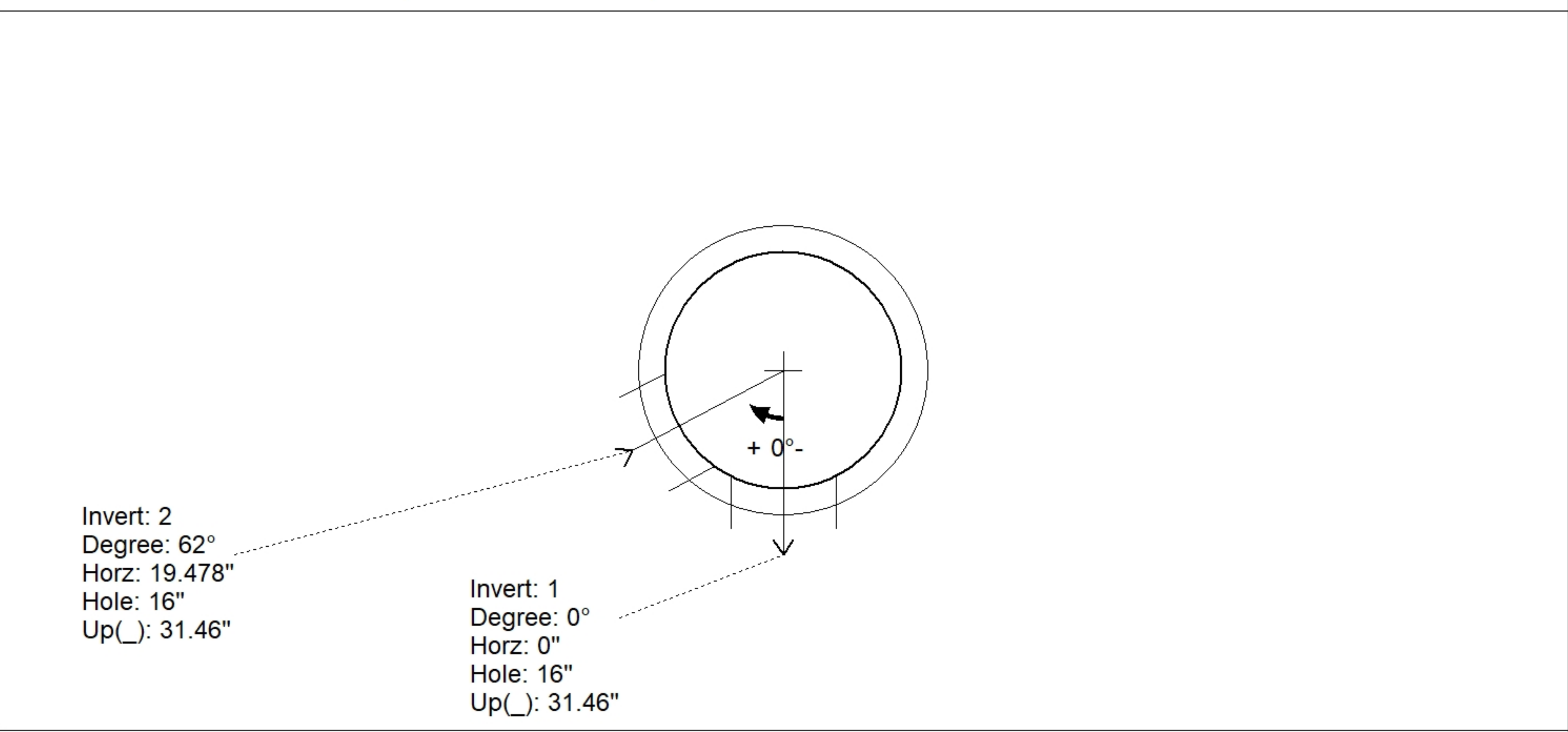
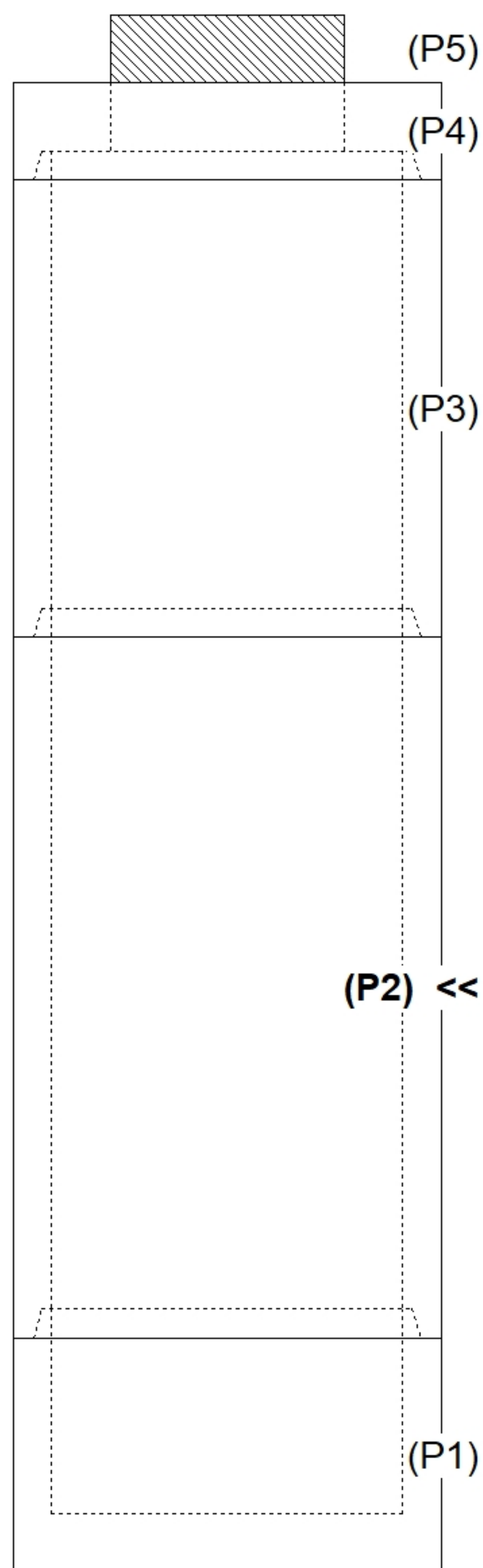

Coating (Int): Coating (Ext):	Seam Up: Tongue Seam Dn: Groove	Wall Thickness: 4" Floor Height: 0"	Height (Int): 72" Height (Ext): 72"	Weight (Net): 2898 lb Volume (Net): 0.74cu.yd
----------------------------------	------------------------------------	----------------------------------------	----------------------------------------	--------------------------------------------------