

Job Name: 25-4733 - The Paddock
 Job Location: Springfield, KY
 Contractor: Core & Main LP (Lou)

Plant: 100

Tech: Jared - F

5/14/2026 1:09:00 PM

PC: T. Lewis



Structure ID: STMH-D1

P1 MH048BA36

MH BASE T/n

- P3) 24" - CASTING HEIGHT - 7"
- P2) 48" - MH FLAT TOP w/ 24" ECC Hole F/G - 12"
- P1) 48" - MH BASE T/n - 36"
- 1) CASTING - HOE MC-315 F/C Storm
- 1) 48" - Conseal CS-102 1.00"
- 2) Hole - 20
- 3) MH Step ML-10-TDS-NCR - 10"

0 lb
 1561 lb
 3575 lb
 258 lb
 0 lb
 0 lb
 0 lb

 Structure Total: 5394 lb

Structure Notes:

1. PER ASTM C478 SPECIFICATIONS.
2. CONCRETE = 4,000 PSI AT 28 DAYS.
3. NO INVERT CHANNEL.
4. CASTING BY ICAST (HOE MC-315 F/C STORM).

REINFORCING PER ASTM A615 (GRADE 60).
 - TOP SLAB (As .62) #5 BARS AT 6" C.C.E.W..
 - RISER/WALLS (As .12)
 - FLOOR (As .31) #5 BARS AT 12" C.C.E.W.

Rim: 885.01' Rim to Invert: 4.55' Slack: 0.9" Sump: 1.3" Step Position: 270

Position	Elev	Angle	Ext. (cw)	Pipe	Pipe OD	Connector	Hole	Horz Size	Up ()	Offset
Invert 1	880.46'	0°	0"	15" HDPE	17.6"	Hole 20	20"	20.629"	0"	0"
Invert 2	880.46'	102°	51.625"	15" HDPE	17.6"	Hole 20	20"	20.629"	0"	0"
Invert 3										
Invert 4										
Invert 5										
Invert 6										
Invert 7										
Invert 8										

RIGHT-SIDE UP VIEW (int. dimensions)

UPSIDE-DOWN VIEW (int. dimenions)

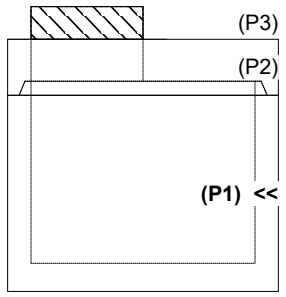
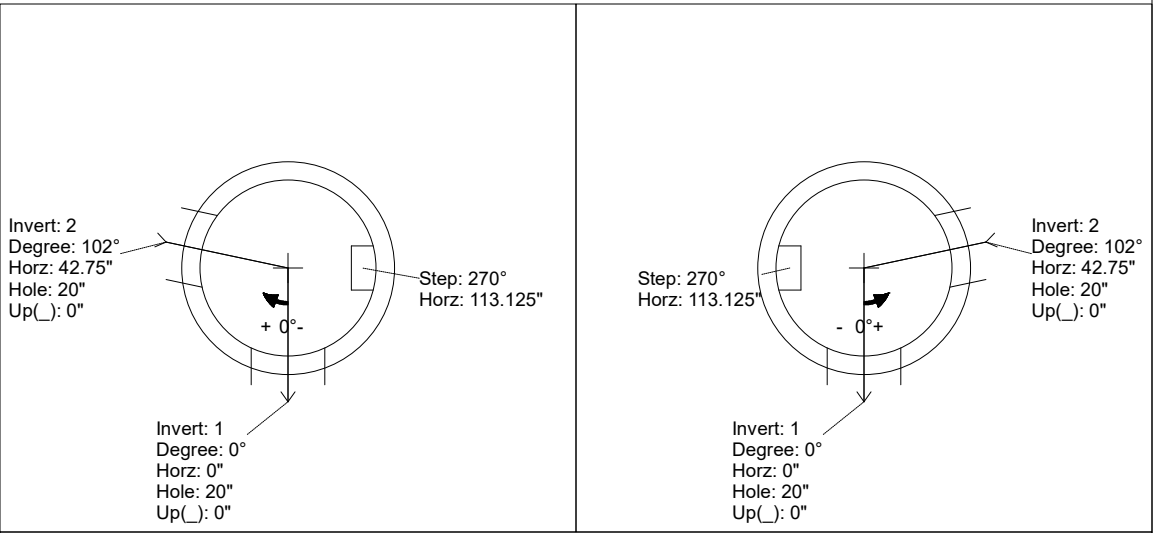

INSIDE WALL DIMENSIONS

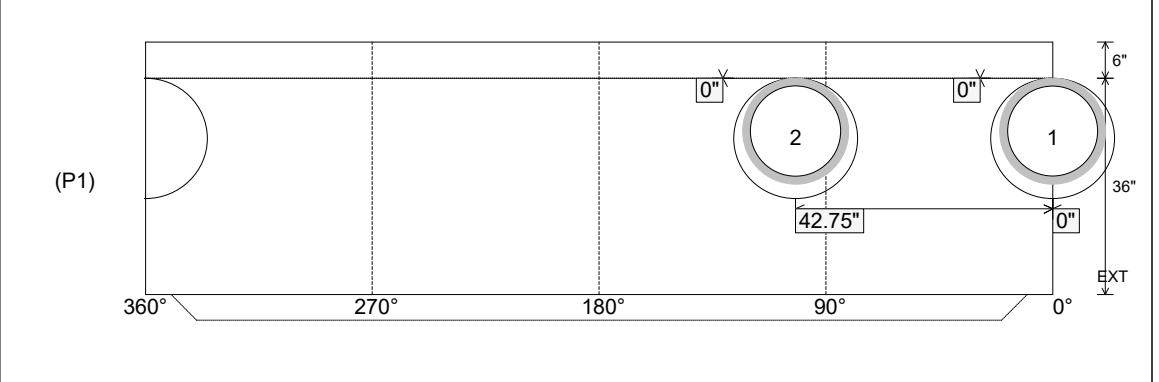

Coating (Int): Coating (Ext):	Seam Up: Tongue Seam Dn: n/a	Wall Thickness: 5" Floor Height: 6"	Height (Int): 36" Height (Ext): 42"	Weight (Net): 3575 lb Volume (Net): 0.91cu.yd
----------------------------------	---------------------------------	--	--	--