

Job Name: 25-4733 - The Paddock
 Job Location: Springfield, KY
 Contractor: Core & Main LP (Lou)

Plant: 100
 5/14/2026 1:09:02 PM

Tech: Jared - F
 PC: T. Lewis



Structure ID: CI-D3

P1 BX2436-08BVF

BOX BASE 8inW, 8inF, Variable Ht F/n

- P2) 24" x 36" - CASTING HEIGHT - 6"
- P1) 24" x 36" - BOX BASE 8inW, 8inF, Variable Ht F/n - 34"
- 1) CASTING - HOE 525 SET FLAT GRATE (F/G/H)
- 1) 24" x 36" - Conseal CS-102 1.00"
- 1) Hole - 20

0 lb
 4641 lb
 442 lb
 0 lb
 0 lb

 5083 lb

Structure Total: 5083 lb

Structure Notes:
 1. PER ASTM C913 SPECIFICATIONS.
 2. CONCRETE = 4,000 PSI AT 28 DAYS.
 3. NO STEPS AND NO INVERT CHANNEL.
 4. CASTING BY ICAST (HOE 525 SET FLAT GRATE (F/G/H)).

REINFORCING PER ASTM A615 (GRADE 60).
 - WALLS (As .12) #5 BARS AT 12" C.C.E.W.
 - FLOOR (As .12) #5 BARS AT 12" C.C.E.W.

Rim: 884.95' Rim to Invert: 3.39' Slack: 1.93' Sump: 1.25' Step Position:

Position	Elev	Angle	Ext. (cw)	Pipe	Pipe OD	Connector	Hole	Horz Size	Up ()	Offset
Invert 1	881.56'	70°	23"	15" HDPE	17.6"	Hole 20	20"	21.284"	0"	4"
Invert 2										
Invert 3										
Invert 4										
Invert 5										
Invert 6										
Invert 7										
Invert 8										

RIGHT-SIDE UP VIEW (int. dimensions)

UPSIDE-DOWN VIEW (int. dimenions)

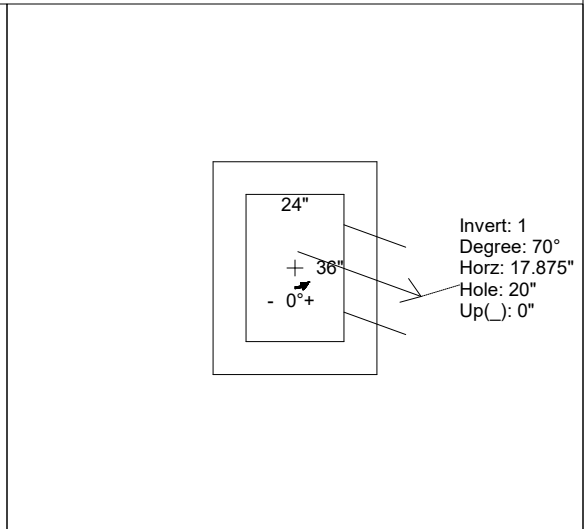
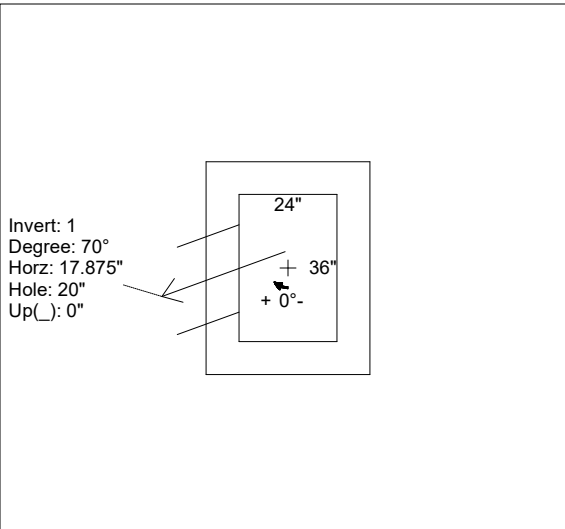
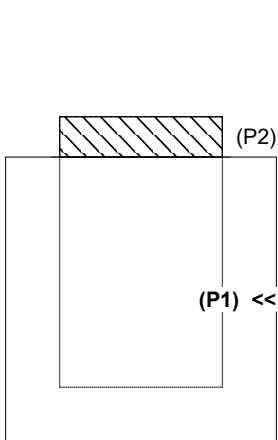

INSIDE WALL DIMENSIONS

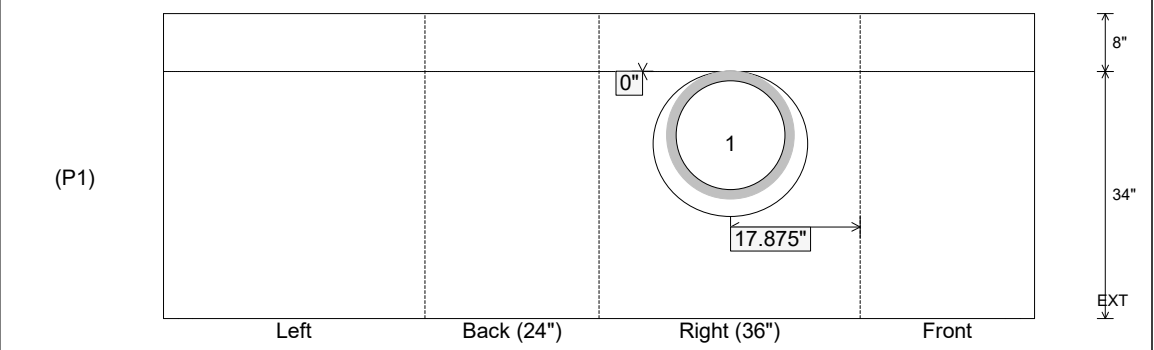

Coating (Int):
 Coating (Ext):

Seam Up: Flat
 Seam Dn: n/a

Wall Thickness: 8"
 Floor Height: 8"

Height (Int): 34"
 Height (Ext): 42"

Weight (Net): 4641 lb
 Volume (Net): 1.18cu.yd