

Job Name: 26-1368 Freeman Lake Park Parking Lot Project
 Job Location: Elizabethtown, KY
 Contractor: Kauffeld Brothers Construction

Plant: Beaver Dam
 5/28/2026 9:51:48 AM

Tech: S. Felletter
 PC: T. Ryan



Structure ID: JB #1-6 JBB

P3 BX024030-08LD08S

BX FLAT LID 8inW SPEC. (KY JB-B1) F/F

- P4) CASTING (cast in) - 0
- P3) 24" x 30" - BX FLAT LID 8inW SPEC. (KY JB-B1) F/F - 8"
- P2) 24" x 30" - BOX RISER 8inW F/G - 24"
- P1) 24" x 30" - BOX BASE 8inW, 8inF T/n - 48"
- 1) CASTING - HOE KY-206 F/C (KY TY1)
- 1) This Structure Includes a Cast-in Item
- 2) 24" x 30" - Conseal CS-102 1.00"
- 1) 24" - Conseal CS-102 1.00"
- 2) Hole - 24

0 lb
 931 lb
 2256 lb
 5139 lb
 206 lb
 0 lb
 0 lb
 0 lb
 0 lb
 0 lb
 Structure Total: 8532 lb

Structure Notes:
 1. KYTC JUNCTION BOX B1 / PER ASTM C913 SPEC'S.
 2. CONCRETE = 4,000 PSI AT 28 DAYS.
 3. TOP SLAB w KYTC TYPE 1 F/C CAST FLUSH.
 4. CASTING BY ICAST (HOE KY-206 F/C). CAST-IN.
 REINFORCING PER ASTM A615 (GRADE 60).
 - TOP SLAB (As. 62) #5 BARS AT 4" C.C.E.W.
 - WALLS (As .31) #5 BARS AT 12" C.C.E.W.
 - FLOOR (As .31) #5 BARS AT 12" C.C.E.W.

NOTES:

1. MANUFACTURED TO KYTC JUNCTION BOX B1/ASTM C-931 (LATEST REVISION).
2. CONCRETE: 4,000 PSI AT 28 DAYS.
3. REINFORCING: #5 BAR @ 4" C.C. E.W. (GRADE 60).
4. CASTING BY ICAST (HOE KY-206 F/C). CAST-IN.

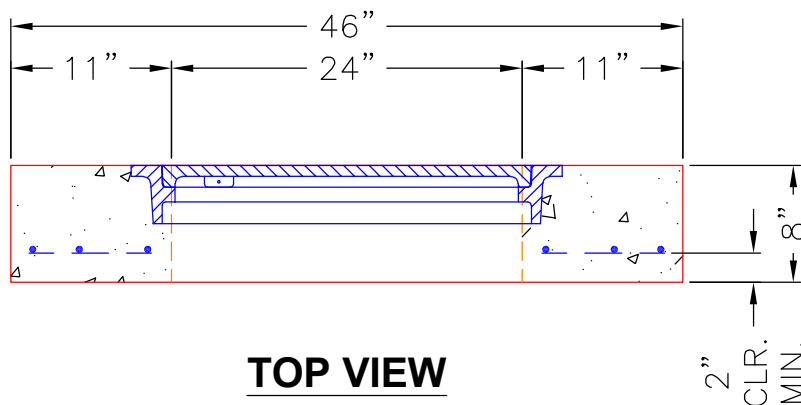
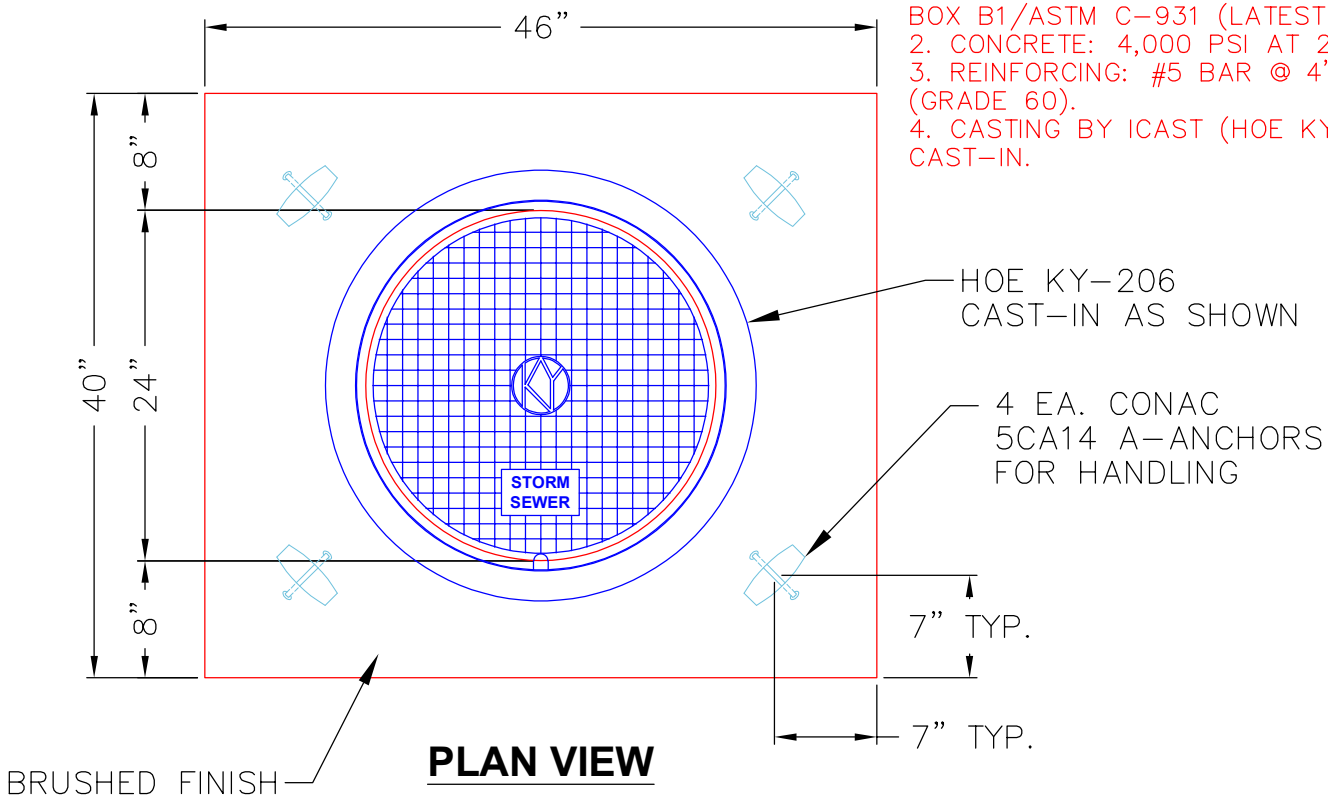

Coating (Int):
 Coating (Ext):

Seam Up: Flat
 Seam Dn: Flat

Wall Thickness: 8"

Height (Ext): 8"

Weight (Net): 931 lb
 Volume (Net): 0.24cu.yd