

Job Name: 25-2422 - Woodland Springs Section 3 (Sanitary)
 Job Location: Clarksville, TN
 Contractor: Byard Construction, LLC

Plant: 100

5/14/2026 2:17:30 PM

Tech: Jared - A

PC: A. Chambers



Structure ID: B-1

P3 MH048CN30CDARED

ECC CONE w/ 24" HOLE, w/ConBlock-CDA Red F/G

P5) 24" - CASTING HEIGHT - 6"	0 lb
P4) 24" - GRADE RING w/ConBlock-CDA Red F/F - 3"	202 lb
P3) 48" - ECC CONE w/ 24" HOLE, w/ConBlock-CDA Red F/G - 30"	1961 lb
P2) 48" - MH RISER w/ConBlock-CDA Red T/G - 48"	3353 lb
P1) 48" - MH BASE w/ConBlock-CDA Red T/n - 24"	2911 lb
1) 48" - MH INVERT CHANNEL w/ConBlock-CDA Red - FULL HEIGHT	1440 lb
1) JOINT WRAP - 0.065"x6"x50" CONSEAL CS212	0 lb
1) JOINT WRAP PRIMER - CONSEAL CS-75 (1 gal.)	0 lb
1) ADMIXTURE CONBLOCK CDA RED	0 lb
1) CASTING - JBS 1155 F/C SANITARY	250 lb
2) 48" - Conseal CS-102 1.00" (Double)	0 lb
1) 24" - Conseal CS-102 1.00" (Double)	0 lb
2) PSX - 12-08 NYLO	16 lb
9) MH Step ML-10-TDS-NCR - 10"	0 lb
Structure Total:	10134 lb

Structure Notes:
 1. PER ASTM C-478 SPECIFICATIONS
 2. CONCRETE: 4,000 PSI AT 28 DAYS
 3. REINFORCEMENT: PER ASTM A615
 4. CONBLOCK CDA RED ADMIXTURE REQUIRED
 5. STEPS REQUIRED
 6. JBS 1155 FRAME & COVER "SANITARY" SUPPLIED BY ICAST

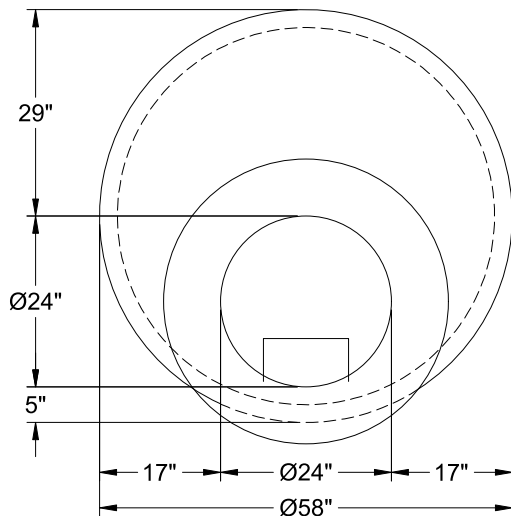

48" - ECC CONE w/ 24" HOLE, w/ConBlock-CDA Red F/G - 30" - (P3)

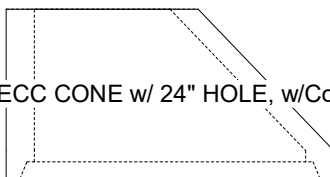

Coating (Int):
 Coating (Ext):

Seam Up: Flat
 Seam Dn: Groove

Wall Thickness: 5"

Height (Ext): 30"

Weight (Net): 1961 lb
 Volume (Net): 0.5cu.yd