

Job Name: 25-2422 - Woodland Springs Section 3 (Sanitary)  
 Job Location: Clarksville, TN  
 Contractor: Byard Construction, LLC

Plant: 100

5/14/2026 2:17:28 PM

Tech: Jared - A

PC: A. Chambers



**Structure ID: A-7**

**P3 MH048CN42CDARED**

**ECC CONE w/ 24" HOLE, w/ConBlock-CDA Red F/G**

P4) 24" - CASTING HEIGHT - 6"	0 lb
P3) 48" - ECC CONE w/ 24" HOLE, w/ConBlock-CDA Red F/G - 42"	3116 lb
P2) 48" - MH RISER SPECIAL w/ConBlock-CDA Red T/G - 60"	4170 lb
P1) 48" - MH BASE w/ConBlock-CDA Red T/n - 36"	3749 lb
1) 48" - MH INVERT CHANNEL w/ConBlock-CDA Red - FULL HEIGHT	1440 lb
1) JOINT WRAP - 0.065"x6"x50' CONSEAL CS212	0 lb
1) JOINT WRAP PRIMER - CONSEAL CS-75 (1 gal.)	0 lb
1) ADMIXTURE CONBLOCK CDA RED	0 lb
1) CASTING - JBS 1155 F/C SANITARY	250 lb
2) 48" - Conseal CS-102 1.00" (Double)	0 lb
1) 24" - Conseal CS-102 1.00" (Double)	0 lb
2) PSX - 12-08 NYLO	16 lb
1) PSX - 8QRS DD	6 lb
12) MH Step ML-10-TDS-NCR - 10"	0 lb
<b>Structure Total:</b>	<b>12749 lb</b>

Structure Notes:  
 1. PER ASTM C-478 SPECIFICATIONS  
 2. CONCRETE: 4,000 PSI AT 28 DAYS  
 3. REINFORCEMENT: PER ASTM A615  
 4. CONBLOCK CDA RED ADMIXTURE REQUIRED  
 5. STEPS REQUIRED  
 6. JBS 1155 FRAME & COVER "SANITARY" SUPPLIED BY ICAST

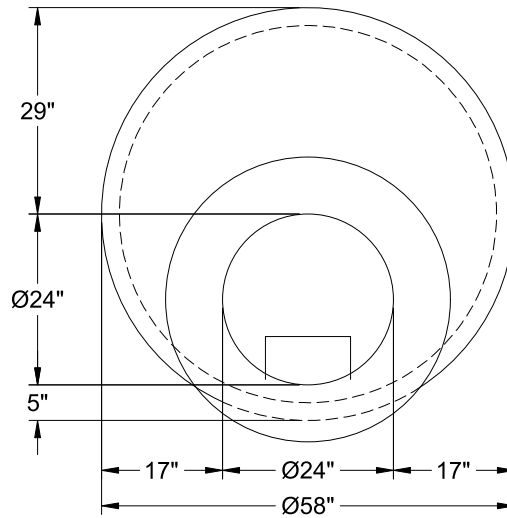

48" - ECC CONE w/ 24" HOLE, w/ConBlock-CDA Red F/G - 42" - (P3)



Coating (Int): Coating (Ext):	Seam Up: Flat Seam Dn: Groove	Wall Thickness: 5"	Height (Ext): 42"	Weight (Net): 3116 lb Volume (Net): 0.8cu.yd
----------------------------------	----------------------------------	--------------------	-------------------	---