

Job Name: 25-4279 - KYTC Christian Co (251031)
 Job Location: Hopkinsville, KY
 Contractor: CITCO Water

Plant: 100
 5/8/2026 11:23:27 AM

Tech: Jared- F
 PC: C. Goff



Structure ID: 90+66 ARV

P2 MH048DHVF

MH DH RISER Custom Ht T/F

- P4) 24" - CASTING HEIGHT - 7"
- P3) 48" - MH FLAT TOP w/ 24" ECC Hole F/G - 12"
- P2) 48" - MH DH RISER Custom Ht T/F - 35"
- P1) 48" - P.I.P. BY OTHERS - BTM SLAB F/n - 0"
- 1) JOINT WRAP - 0.065"x6"x50' CONSEAL CS212
- 1) JOINT WRAP PRIMER - CONSEAL CS-75 (1 gal.)
- 2) 48" - Conseal CS-102 1.00" (Double)
- 2) DOGHOUSE - 8"x8"

0 lb
 1561 lb
 2370 lb
 0 lb
 0 lb
 0 lb
 0 lb
 0 lb
 0 lb

 Structure Total: 3931 lb

Structure Notes:
 1. PER ASTM C478 SPECIFICATIONS.
 2. CONCRETE = 4,000 PSI AT 28 DAYS.
 3. NO STEPS.
 4. CASTING SUPPLIED BY OTHERS.

 REINFORCING PER ASTM A615 (GRADE 60).
 - TOP SLAB = H20 LOADING.
 - RISER/WALLS (As .12)

Rim: 529.99' Rim to Invert: 4' Slack: 0" Sump: 6" Step Position:

Position	Elev	Angle	Ext. (cw)	Pipe	Pipe OD	Connector	Hole	Horz Size	Up ()	Offset
Invert 1	525.99'	0°	0"	4" PVC SDR21	4.375"	DOGHOUSE 8"x8"	8" x 8"	8.038"	4"	0"
Invert 2	525.99'	180°	91.125"	4" PVC SDR21	4.375"	DOGHOUSE 8"x8"	8" x 8"	8.038"	4"	0"
Invert 3										
Invert 4										
Invert 5										
Invert 6										
Invert 7										
Invert 8										

RIGHT-SIDE UP VIEW (int. dimensions)

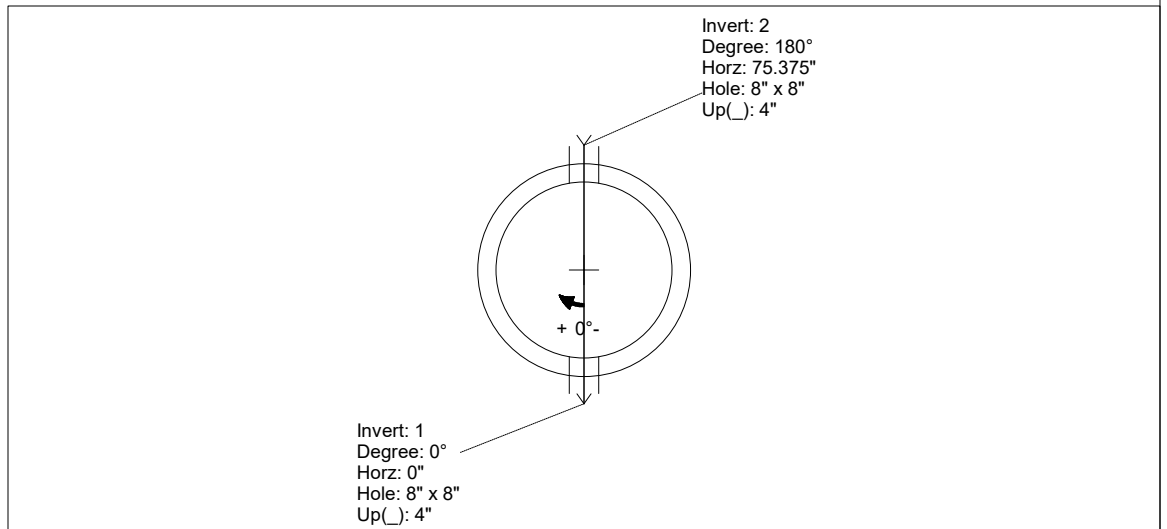
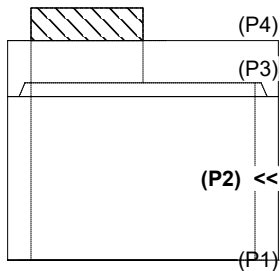

INSIDE WALL DIMENSIONS

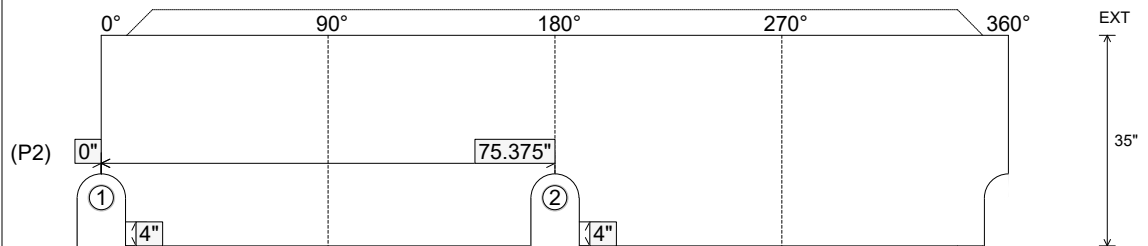

Coating (Int):
 Coating (Ext):

Seam Up: Tongue
 Seam Dn: Flat

Wall Thickness: 5"
 Floor Height: 0"

Height (Int): 35"
 Height (Ext): 35"

Weight (Net): 2370 lb
 Volume (Net): 0.6cu.yd