

Job Name: 25-3310 - Mammoth Cave NP-MACA 12  
 Job Location: Mammoth Cave , KY  
 Contractor: Phillips Brothers

Plant: 100

5/5/2026 5:08:55 PM

Tech: J. Horsley - F

PC: C. Goff



**Structure ID: SAN**

**P2 MH048RSVF**

**MH RISER Custom Ht T/F**

- P5) 24" - CASTING HEIGHT - 7" 0 lb
- P4) 48" - ECC CONE w/ 24" HOLE F/G - 42" 3200 lb
- P3) 48" - MH RISER T/G - 24" 1677 lb
- P2) 48" - MH RISER Custom Ht T/F - 62" 4137 lb
- P1) 48" - P.I.P. BY OTHERS - BTM SLAB F/n - 0" 0 lb
- 1) JOINT WRAP - 0.065"x6"x50' CONSEAL CS212 0 lb
- 1) JOINT WRAP PRIMER - CONSEAL CS-75 (1 gal.) 0 lb
- 3) 48" - Conseal CS-102 1.00" (Double) 0 lb
- 2) DOGHOUSE - 12"x16" 0 lb
- 1) PSX - 12-08 NYLO 8 lb
- 11) MH Step ML-10-TDS-NCR - 10" 0 lb

Structure Total: 9022 lb

**Structure Notes:**  
 1. PER ASTM C478 SPECIFICATIONS.  
 2. CONCRETE = 4,000 PSI AT 28 DAYS.  
 3. CASTING SUPPLIED BY OTHERS - MC-350

REINFORCING PER ASTM A615 (GRADE 60).  
 - CONE (As .12)  
 - RISER/WALLS (As .18)

Rim: 738.5' Rim to Invert: 10.96' Slack: 0.52" Sump: 4" Step Position: 270°

Position	Elev	Angle	Ext. (cw)	Pipe	Pipe OD	Connector	Hole	Horz Size	Up ( )	Offset
Invert 1	727.54'	0°	0"	8" PVC SDR35	8.5"	DOGHOUSE 12"x16"	12" x 16"	12.129"	0"	0"
Invert 2	731.1'	58°	29.375"	8" PVC SDR35	8.5"	PSX 12-08 NYLO	12"	12.129"	44.75"	0"
Invert 3	727.56'	180°	91.125"	8" PVC SDR35	8.5"	DOGHOUSE 12"x16"	12" x 16"	12.129"	0.25"	0"
Invert 4										
Invert 5										
Invert 6										
Invert 7										
Invert 8										

**RIGHT-SIDE UP VIEW (int. dimensions)**

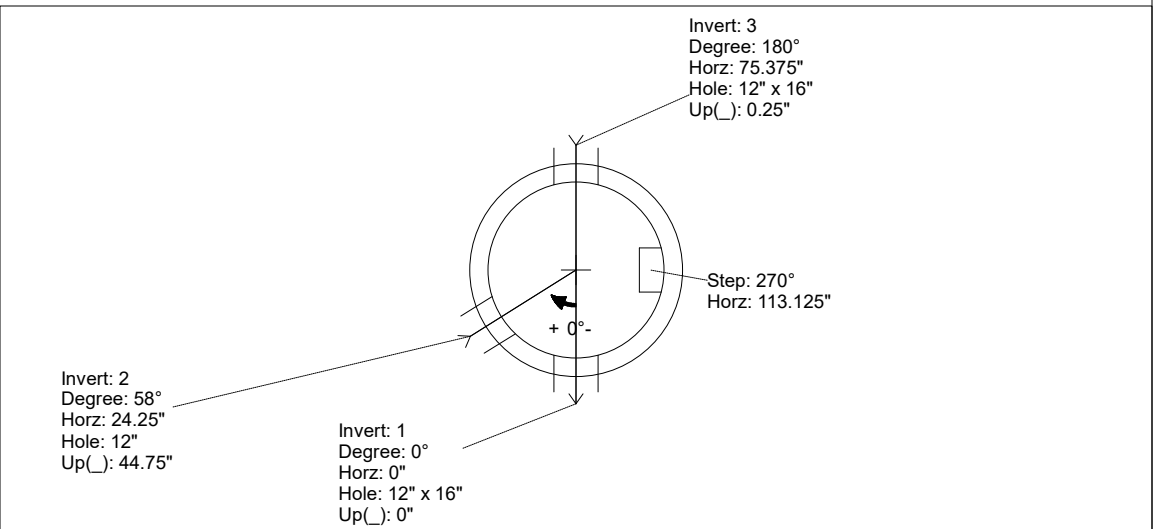
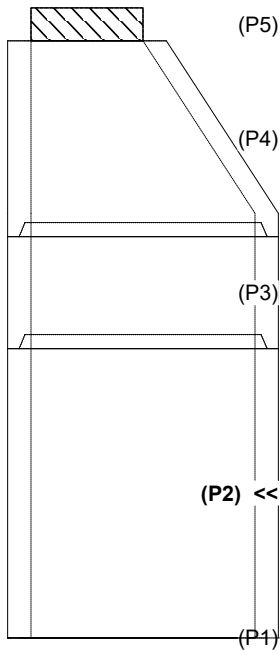

**INSIDE WALL DIMENSIONS**

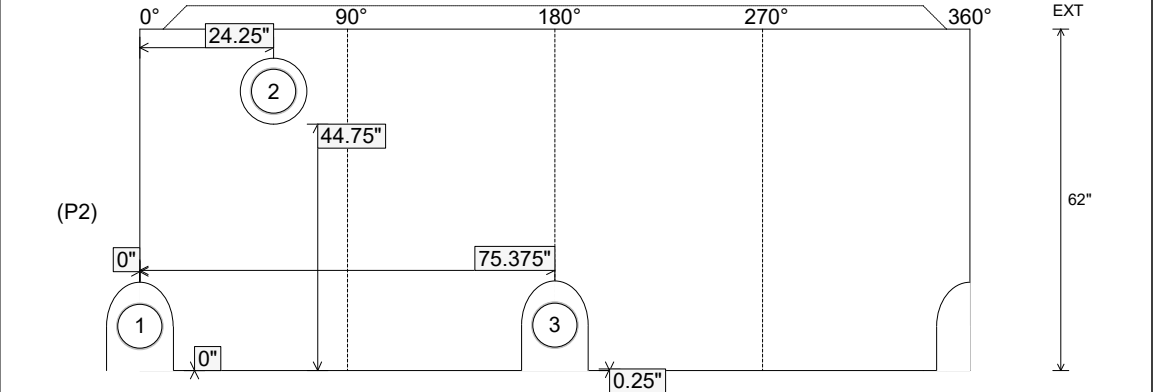

Coating (Int): Coating (Ext):	Seam Up: Tongue Seam Dn: Flat	Wall Thickness: 5" Floor Height: 0"	Height (Int): 62" Height (Ext): 62"	Weight (Net): 4137 lb Volume (Net): 1.06cu.yd
----------------------------------	----------------------------------	--	--	--