

Job Name: 25-3310 - Mammoth Cave NP-MACA 12
 Job Location: Mammoth Cave, KY
 Contractor: Phillips Brothers

Plant: 100

Tech: J. Horsley - F

5/5/2026 5:08:04 PM

PC: C. Goff



Structure ID: INL 10B

P1 BX3636-08BAVF

BOX BASE 8inW, 8inF, Variable Ht F/n

- P2) 36" x 36" - P.I.P. - BY OTHERS - 8"
- P1) 36" x 36" - BOX BASE 8inW, 8inF, Variable Ht F/n - 35"
- 1) 36" x 36" - Conseal CS-102 1.00"
- 1) Hole - 22
- 1) Hole - 16
- 2) Hole - 2

0 lb
 5556 lb
 0 lb
 0 lb
 0 lb
 0 lb
 0 lb
 Structure Total: 5556 lb

Structure Notes:
 1. PER ASTM C913 SPECIFICATIONS.
 2. CONCRETE = 4,000 PSI AT 28 DAYS.
 3. NO INVERT CHANNEL.
 4. CASTING SUPPLIED BY OTHERS - KY-316
 5. #5 DOWELS @ 12" O.C. STUBBED 12" OUT THE TOP OF THE WALLS FOR APRON & GUTTER ATTACHMENT BY OTHERS.

REINFORCING PER ASTM A615 (GRADE 60).
 - WALLS (As .12) #5 BARS AT 6" C.C.E.W.
 - FLOOR (As .12) #5 BARS AT 6" C.C.E.W.

Rim: 741.9' Rim to Invert: 3.64' Slack: 0.68" Sump: 0" Step Position:

Position	Elev	Angle	Ext. (cw)	Pipe	Pipe OD	Connector	Hole	Horz Size	Up ()	Offset
Invert 1	738.26'	0°	26"	15" RCP B WALL	19.5"	Hole 22	22"	22"	-2.25"	0"
Invert 2	738.26'	90°	26"	12" HDPE	14.5"	Hole 16	16"	16"	-1.25"	0"
Invert 3	740.23'	180°	26"	2" WEEP HOLE	2"	Hole 2	2"	2"	23.625"	0"
Invert 4	740.23'	270°	26"	2" WEEP HOLE	2"	Hole 2	2"	2"	23.625"	0"
Invert 5										
Invert 6										
Invert 7										
Invert 8										

RIGHT-SIDE UP VIEW (int. dimensions)

UPSIDE-DOWN VIEW (int. dimensions)

#5 DOWELS @ 12" O.C. STUBBED 12" OUT THE TOP OF THE WALLS

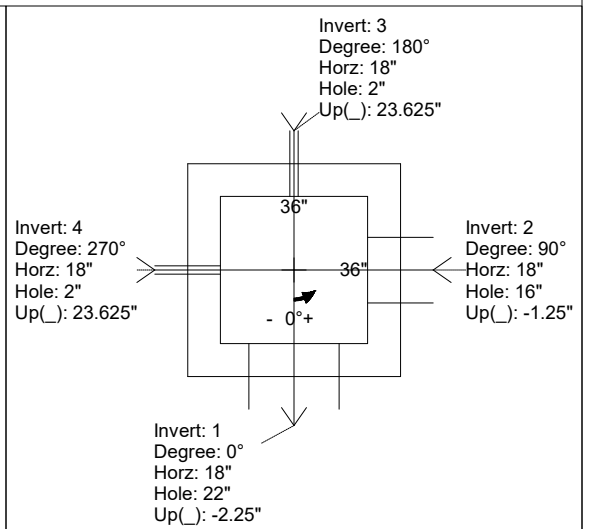
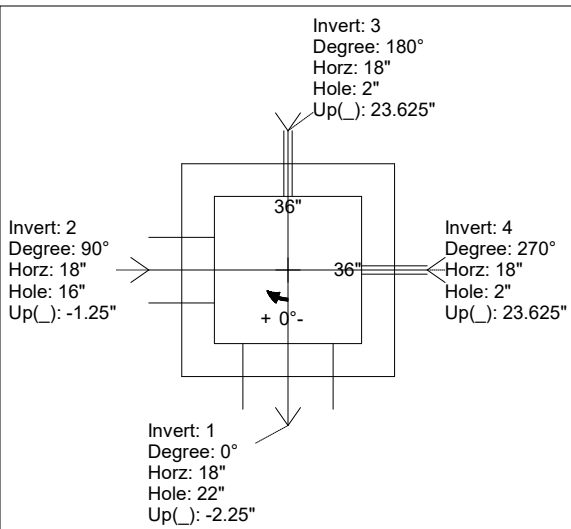
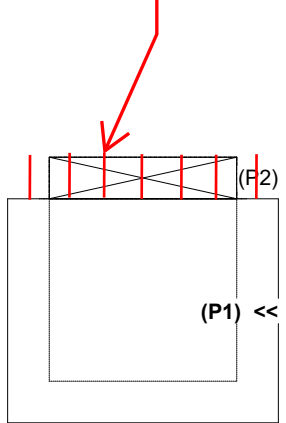

INSIDE WALL DIMENSIONS

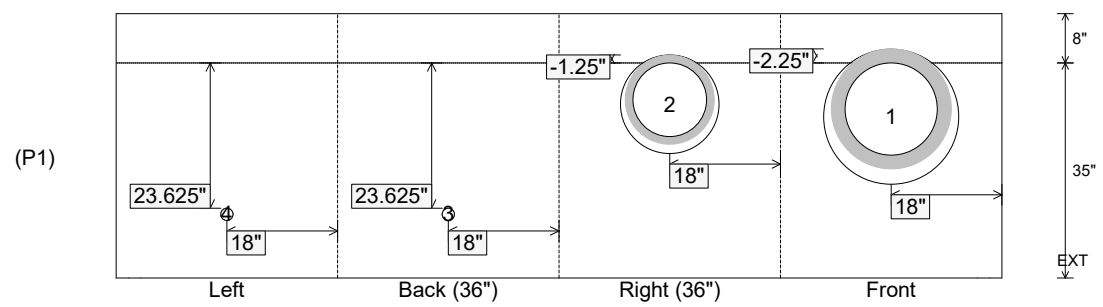

Coating (Int): Coating (Ext):	Seam Up: Flat Seam Dn: n/a	Wall Thickness: 8" Floor Height: 8"	Height (Int): 35" Height (Ext): 43"	Weight (Net): 5556 lb Volume (Net): 1.42cu.yd
----------------------------------	-------------------------------	--	--	--