

Job Name: 26-1075 - Walmart Fuel Station 00674-1008  
 Job Location: Gallatin, TN  
 Contractor: Stewart Richey

Plant: 100

5/26/2026 11:48:23 AM

Tech: Jared - A

PC: T. Lewis



**Structure ID: JB 2 (1)**

**P1 MH048BAEVF**

**MH BASE w/FLANGE T/n**

- P3) 24" - CASTING HEIGHT - 7"
- P2) 48" - MH FLAT TOP w/ 24" ECC Hole F/G - 12"
- P1) 48" - MH BASE w/FLANGE T/n - 36"
- 1) CASTING - JBS 1150 F/C STORM
- 1) 48" - Conseal CS-102 1.00"
- 1) 24" - Conseal CS-102 1.00"
- 2) Hole - 30
- 1) Hole - 12

0 lb  
 1561 lb  
 4722 lb  
 250 lb  
 0 lb  
 0 lb  
 0 lb  
 0 lb  
 0 lb  
 Structure Total: 6533 lb

- Structure Notes:**
1. PER ASTM C-478 SPECIFICATIONS
  2. CONCRETE: 4,000 PSI AT 28 DAYS
  3. REINFORCEMENT: PER ASTM A615
  4. STORM INVERT BY OTHERS
  5. NO STEPS
  6. JBS 1150 FRAME & COVER "STORM" SUPPLIED BY ICAST

Rim: 517.2' Rim to Invert: 4.43' Slack: 0.06" Sump: 1.9" Step Position:

Position	Elev	Angle	Ext. (cw)	Pipe	Pipe OD	Connector	Hole	Horz Size	Up ( )	Offset
Invert 1	512.77'	0°	0"	24" HDPE	27.8"	Hole 30	30"	32.406"	0"	0"
Invert 2	512.77'	225°	113.875"	24" HDPE	27.8"	Hole 30	30"	32.406"	0"	0"
Invert 3	513.35'	297°	150.375"	8" HDPE	9.1"	Hole 12	12"	12.129"	8.25"	0"
Invert 4										
Invert 5										
Invert 6										
Invert 7										
Invert 8										

RIGHT-SIDE UP VIEW (int. dimensions)

UPSIDE-DOWN VIEW (int. dimensions)

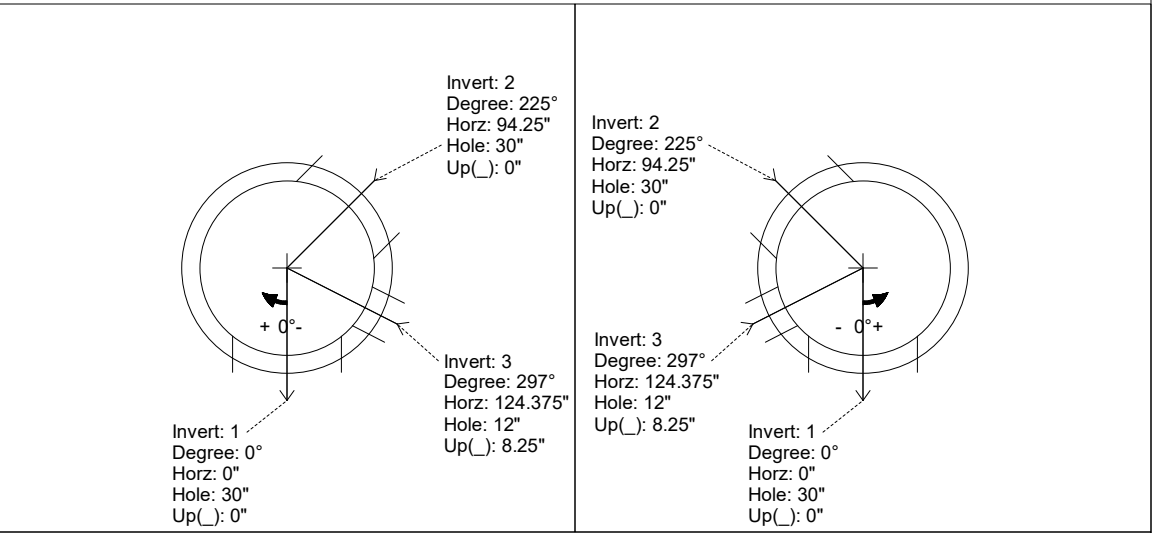
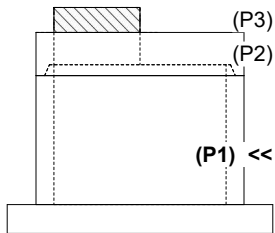

INSIDE WALL DIMENSIONS

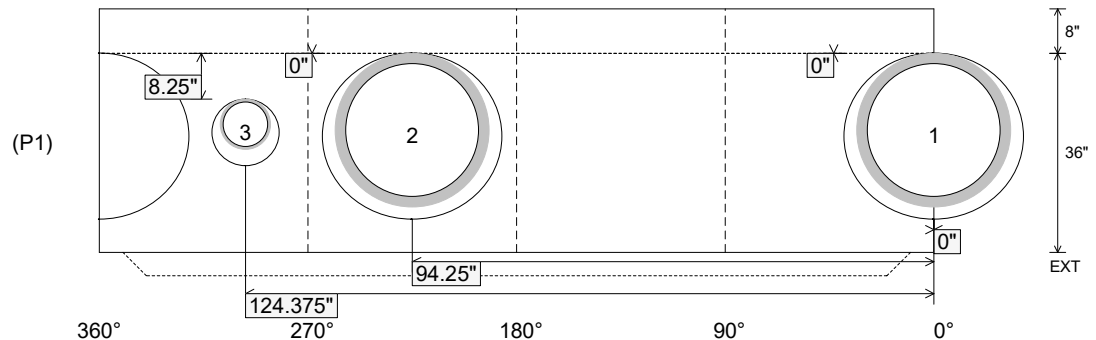

Coating (Int):  
 Coating (Ext):

Seam Up: Tongue  
 Seam Dn: n/a

Wall Thickness: 5"  
 Floor Height: 8"

Height (Int): 36"  
 Height (Ext): 44"

Weight (Net): 4722 lb  
 Volume (Net): 1.21cu.yd