

Job Name: 26-1075 - Walmart Fuel Station 00674-1008  
 Job Location: Gallatin, TN  
 Contractor: Stewart Richey

Plant: 100  
 5/26/2026 12:10:00 PM

Tech: Jared - A  
 PC: T. Lewis



**Structure ID: JB 1 (2)**

**P2 MH048CCN24S**

**CON CONE w/24" HOLE, NO STEPS F/G**

- P3) 24" - CASTING HEIGHT - 7"
- P2) 48" - CON CONE w/24" HOLE, NO STEPS F/G - 24"
- P1) 48" - MH BASE EF Cust. Ht. 08"F (08"EF =74"OD) T/n - 40"
- 1) CASTING - JBS 1150 F/C STORM
- 1) 48" - Conseal CS-102 1.00"
- 1) 24" - Conseal CS-102 1.00"
- 2) Hole - 30

0 lb  
 2252 lb  
 5049 lb  
 250 lb  
 0 lb  
 0 lb  
 0 lb  
 -----  
 Structure Total: 7552 lb

- Structure Notes:
1. PER ASTM C-478 SPECIFICATIONS
  2. CONCRETE: 4,000 PSI AT 28 DAYS
  3. REINFORCEMENT: PER ASTM A615
  4. NO STEPS
  5. JBS 1150 FRAME & COVER "STORM" SUPPLIED BY ICAST

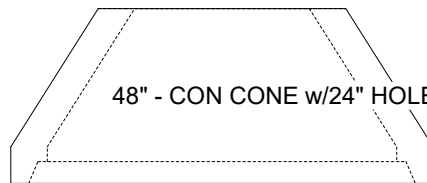
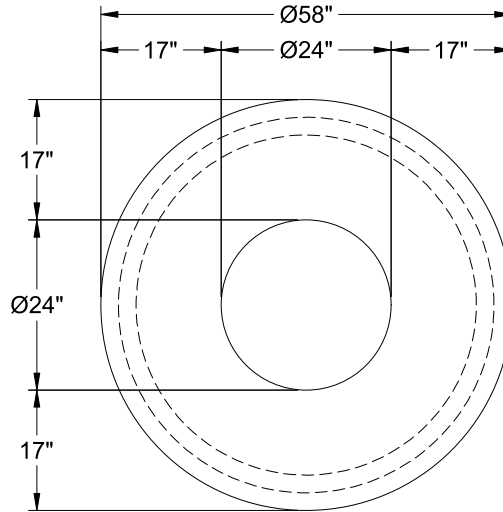

Coating (Int):  
 Coating (Ext):

Seam Up: Flat  
 Seam Dn: Groove

Wall Thickness: 5"

Height (Ext): 24"

Weight (Net): 2252 lb  
 Volume (Net): 0.57cu.yd