

Structure ID: 10-CS-6

P2 MH072RS84

MH RISER T/G

P5) 30" - CASTING HEIGHT - 4" P4) 72" - MH FLAT TOP SPEC. (30" ECC HOLE) F/G - 15" P3) 72" - MH RISER T/G - 60" P2) 72" - MH RISER T/G - 84" P1) 72" - MH BASE T/n - 24" 1) ASSEMBLY REQUIRED 1) CVSTENCILING 3) 72" - Conseal CS-102 1.00" 2) Hole - 16	0 lb 4661 lb 8747 lb 12008 lb 7398 lb 0 lb 0 lb 0 lb 0 lb 0 lb ----- Structure Total: 32814 lb
--	---

Structure Notes:
 4" CASTING BY OTHERS
 .
 LIFTING ANCHORS TO BE INSTALLED ON THE OUTSIDE OF THE STRUCTURE
 .
 ICAST TO INSTALL THE INTERNALS
 .
 CONTECH'S LOGO AS WELL AS THE INLET AND OUTLET MUST BE STENCILED ONTO THE STRUCTURE

Rim: 455.84' Rim to Invert: 10.76' Slack: 11.156" Sump: 69.036" Step Position: 0°

Position	Elev	Angle	Ext. (cw)	Pipe	Pipe OD	Connector	Hole	Horz Size	Up ()	Offset
Invert 1	445.08'	270°	202.633"	10" HDPE	11.4"	Hole 16	16"	16.135"	37.036"	0"
Invert 2	445.08'	157°	117.827"	10" HDPE	11.4"	Hole 16	16"	16.135"	37.036"	0"
Invert 3										
Invert 4										
Invert 5										
Invert 6										
Invert 7										
Invert 8										

RIGHT-SIDE UP VIEW (int. dimensions)

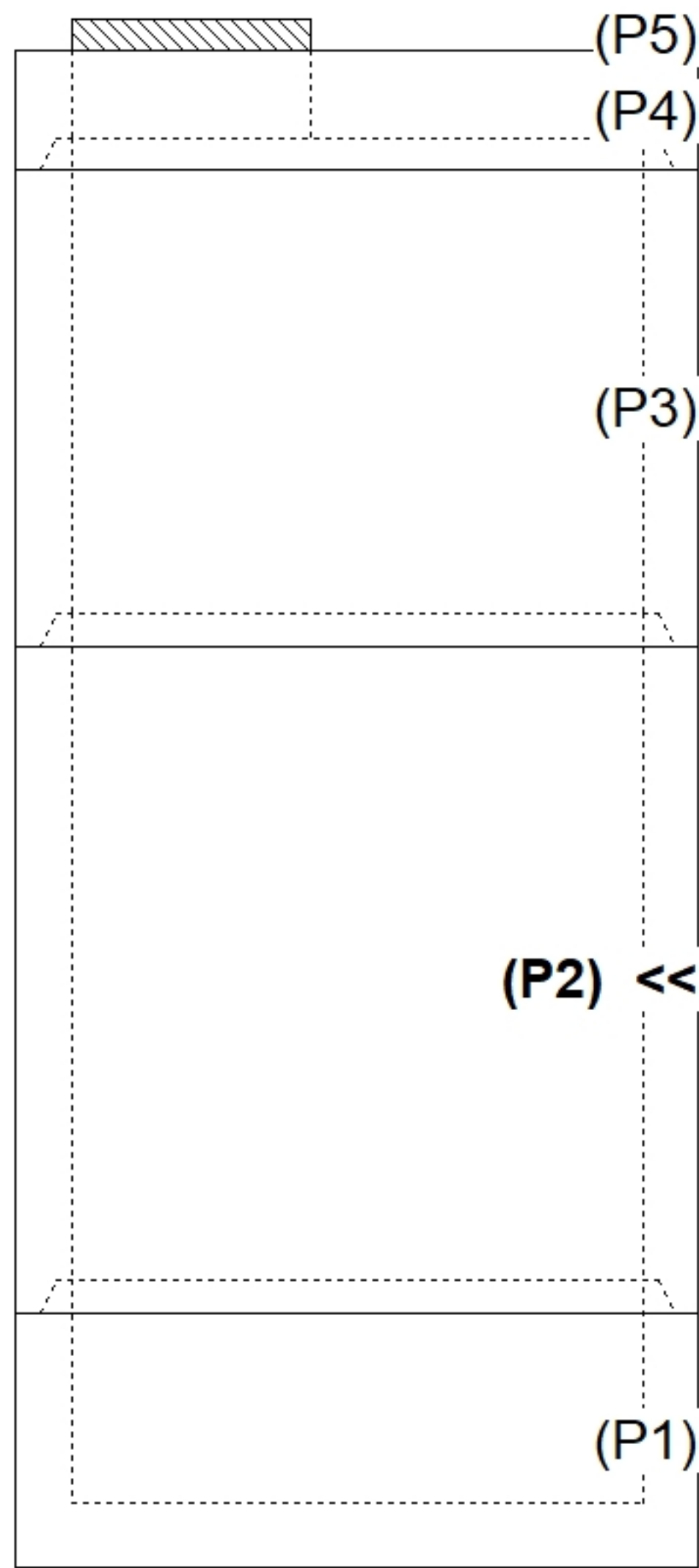

Invert: 2
 Degree: 157°
 Horz: 98.646"
 Hole: 16"
 Up(): 37.036"

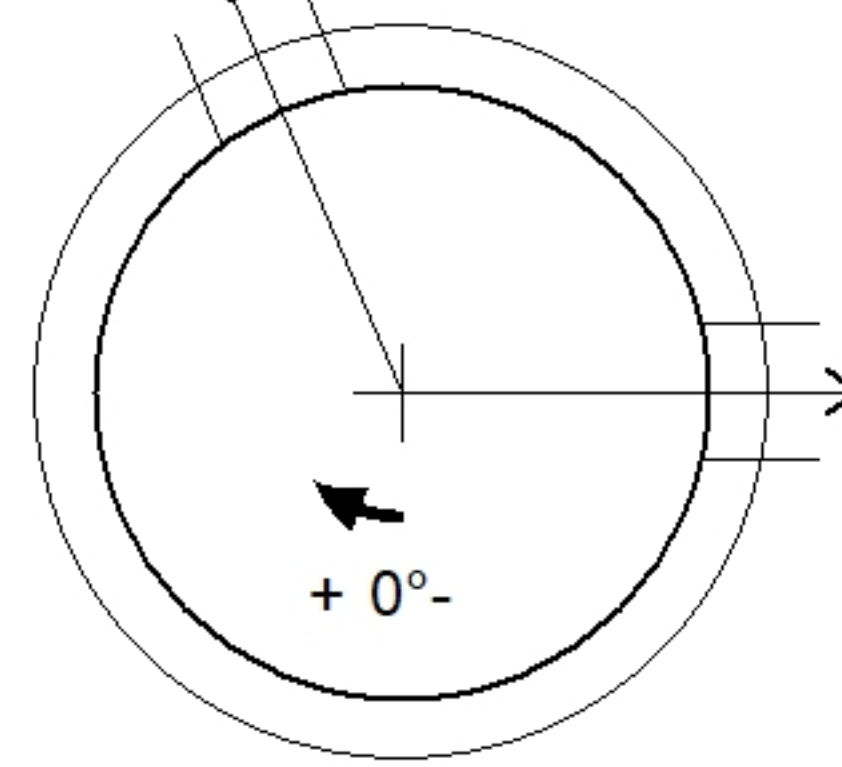

Invert: 1
 Degree: 270°
 Horz: 169.646"
 Hole: 16"
 Up(): 37.036"

INSIDE WALL DIMENSIONS

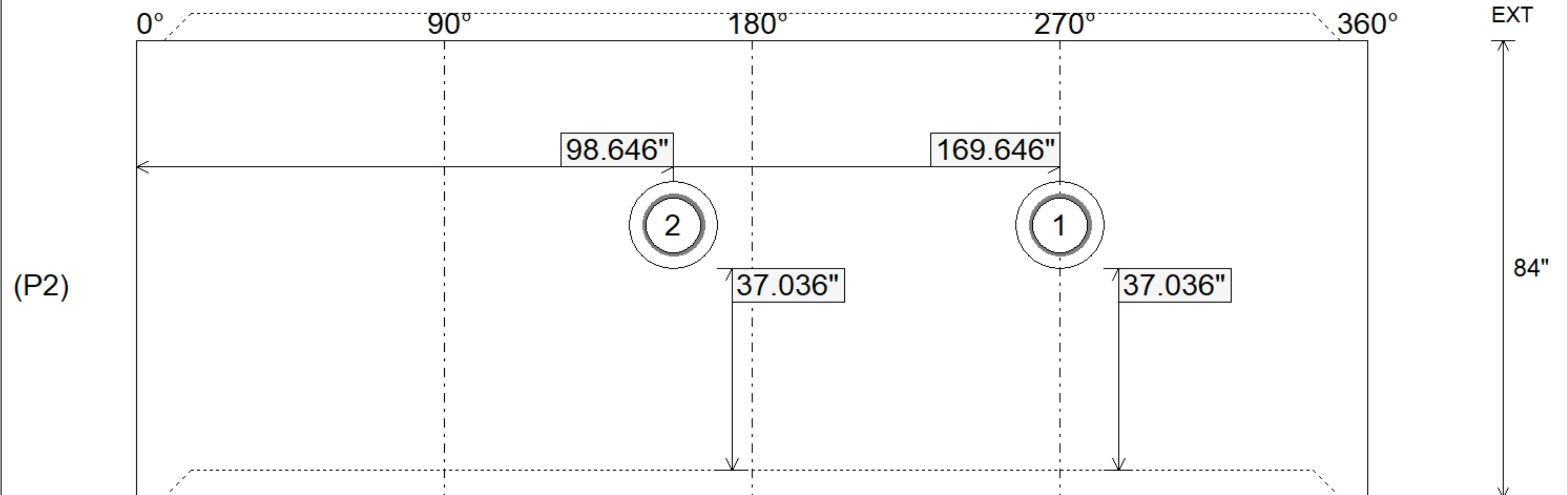

Coating (Int): Coating (Ext):	Seam Up: Tongue Seam Dn: Groove	Wall Thickness: 7" Floor Height: 0"	Height (Int): 84" Height (Ext): 84"	Weight (Net): 12008 lb Volume (Net): 3.07cu.yd
----------------------------------	------------------------------------	--	--	---