

Structure ID: 1

P2 MH036RS60

MH RISER T/G

P6) 24" - CASTING HEIGHT - 7" P5) 24" - GRADE RING F/F - 3" P4) 36" - MH FLAT TOP w/ 24" Ctr. Hole F/G - 10" P3) 36" - MH RISER T/G - 24" P2) 36" - MH RISER T/G - 60" P1) 36" - MH BASE T/n - 18" 1) JOINT WRAP - 0.065"x6"x50' CONSEAL CS212 1) JOINT WRAP PRIMER - CONSEAL CS-75 (1 gal.) 1) ASSEMBLY REQUIRED 1) CASTING - HOE MC-375 F/C Storm 3) 36" - Conseal CS-102 1.00" (Double) 2) Hole - 12	0 lb 202 lb 896 lb 1012 lb 2454 lb 1525 lb 0 lb 0 lb 0 lb 271 lb 0 lb 0 lb ----- 6360 lb	Structure Notes: 1. PER ASTM C478 SPECIFICATIONS. 2. CONCRETE = 4,000 PSI AT 28 DAYS. 3. CASTING BY ICAST (HOE MC-375 F/C "STORM"). 4. LIFTING ANCHORS TO BE INSTALLED ON THE OUTSIDE OF THE STRUCTURE. REINFORCING PER ASTM A615 (GRADE 60). - TOP SLAB (As .62) #5 BARS AT 6" C.C.E.W.. - RISER/WALLS (As .12) - FLOOR (As .31) #5 BARS AT 12" C.C.E.W.
--	---	--

Structure Total: 6360 lb

Rim: 558' Rim to Invert: 5.64' Slack: 0.64" Sump: 54.96" Step Position:

Position	Elev	Angle	Ext. (cw)	Pipe	Pipe OD	Connector	Hole	Horz Size	Up ()	Offset
Invert 1	552.36'	330°	126.711"	8" HDPE	9.1"	Hole 12	12"	12.234"	31.46"	0"
Invert 2	552.36'	30°	11.519"	8" HDPE	9.1"	Hole 12	12"	12.234"	31.46"	0"
Invert 3										
Invert 4										
Invert 5										
Invert 6										
Invert 7										
Invert 8										

RIGHT-SIDE UP VIEW (int. dimensions)

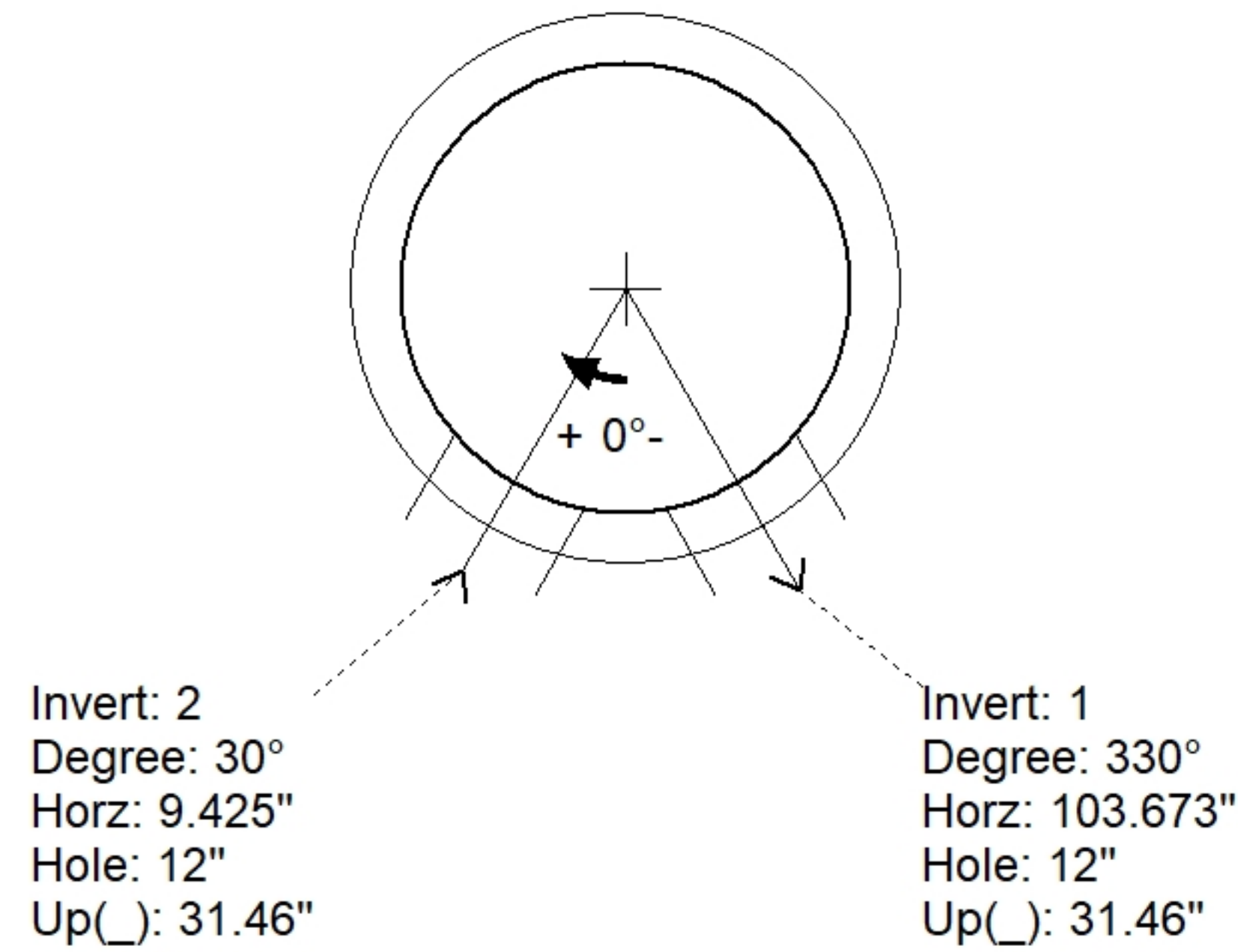
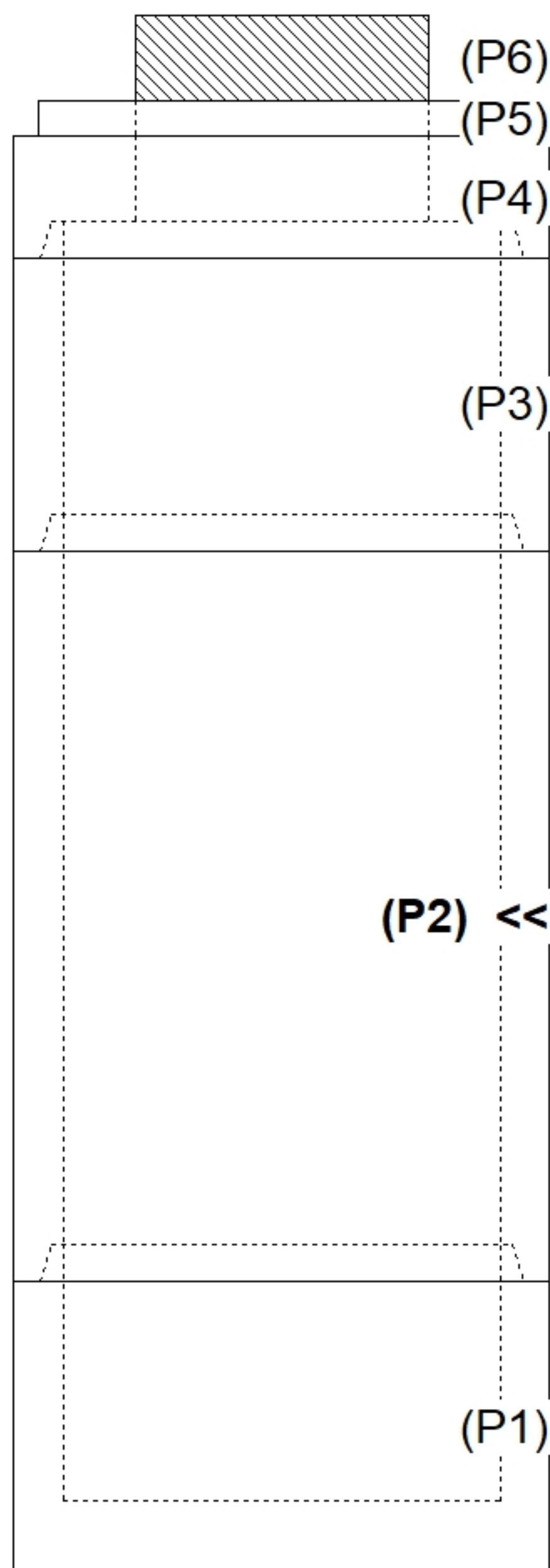

INSIDE WALL DIMENSIONS

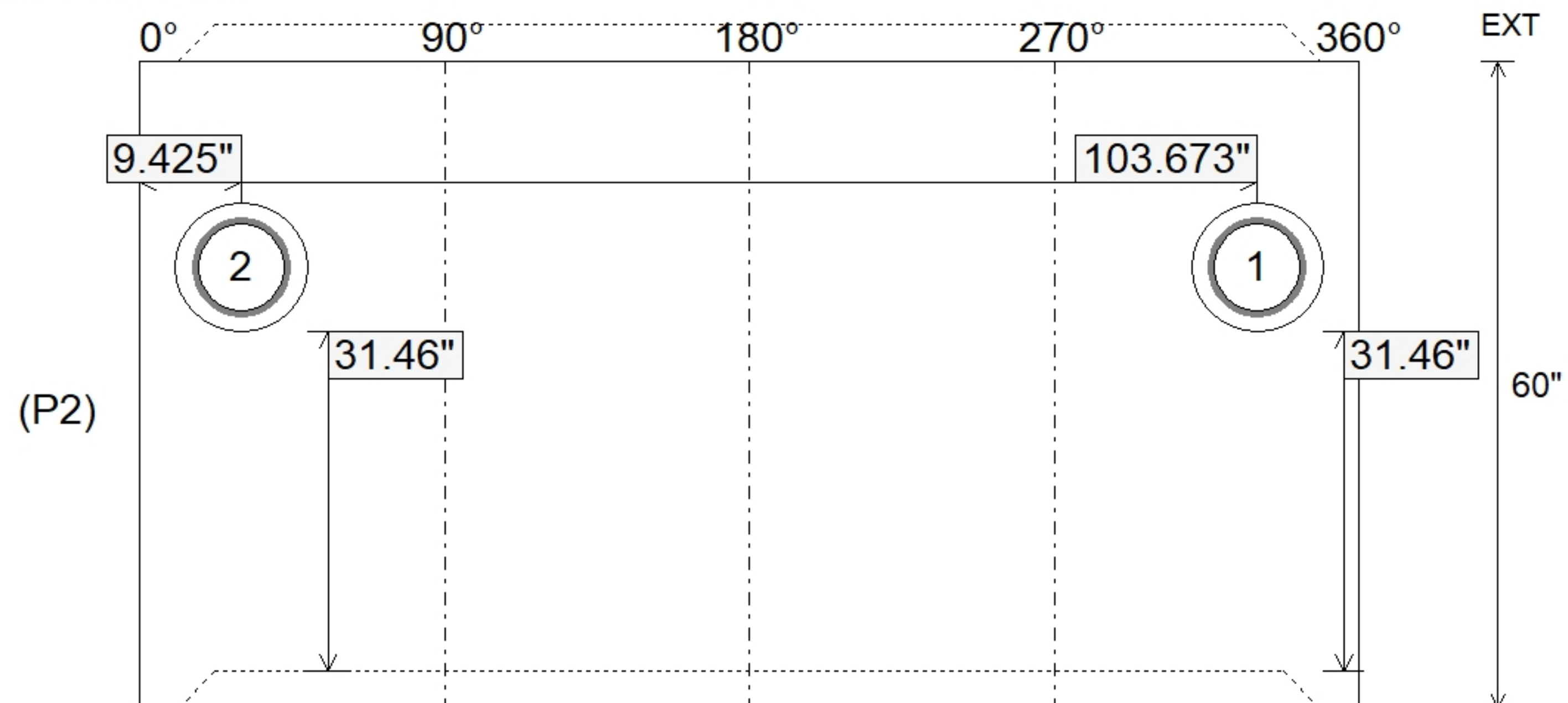

Coating (Int): Coating (Ext):	Seam Up: Tongue Seam Dn: Groove	Wall Thickness: 4" Floor Height: 0"	Height (Int): 60" Height (Ext): 60"	Weight (Net): 2454 lb Volume (Net): 0.63cu.yd
----------------------------------	------------------------------------	--	--	--