

Job Name: 25-2422 - Woodland Springs Section 3 (Sanitary)
 Job Location: Clarksville, TN
 Contractor: Byard Construction, LLC

Plant: 100

Tech: Jared - A

5/14/2026 2:16:53 PM

PC: A. Chambers



Structure ID: A-3

P2 MH048RS60CDARED

MH RISER w/ConBlock-CDA Red T/G

- P5) 24" - CASTING HEIGHT - 6" 0 lb
- P4) 48" - ECC CONE w/ 24" HOLE, w/ConBlock-CDA Red F/G - 36" 2251 lb
- P3) 48" - MH RISER w/ConBlock-CDA Red T/G - 60" 4192 lb
- P2) 48" - MH RISER w/ConBlock-CDA Red T/G - 60" 4192 lb
- P1) 48" - MH BASE w/ConBlock-CDA Red T/n - 30" 3330 lb
- 1) 48" - MH INVERT CHANNEL w/ConBlock-CDA Red - FULL HEIGHT 1440 lb
- 1) JOINT WRAP - 0.065"x6"x50" CONSEAL CS212 0 lb
- 1) JOINT WRAP PRIMER - CONSEAL CS-75 (1 gal.) 0 lb
- 1) ADMIXTURE CONBLOCK CDA RED 0 lb
- 1) CASTING - JBS 1155 F/C SANITARY 250 lb
- 3) 48" - Conseal CS-102 1.00" (Double) 0 lb
- 1) 24" - Conseal CS-102 1.00" (Double) 0 lb
- 2) PSX - 12-08 NYLO 16 lb
- 15) MH Step ML-10-TDS-NCR - 10" 0 lb

- Structure Notes:
1. PER ASTM C-478 SPECIFICATIONS
 2. CONCRETE: 4,000 PSI AT 28 DAYS
 3. REINFORCEMENT: PER ASTM A615
 4. CONBLOCK CDA RED ADMIXTURE REQUIRED
 5. STEPS AT 90 DEGREES
 6. JBS 1155 FRAME & COVER "SANITARY" SUPPLIED BY ICAST

Structure Total: 15670 lb

Rim: 429.93' Rim to Invert: 15.91' Slack: 0.92" Sump: 2" Step Position: 90°

Position	Elev	Angle	Ext. (cw)	Pipe	Pipe OD	Connector	Hole	Horz Size	Up ()	Offset
Invert 1										
Invert 2										
Invert 3										
Invert 4										
Invert 5										
Invert 6										
Invert 7										
Invert 8										

RIGHT-SIDE UP VIEW (int. dimensions)

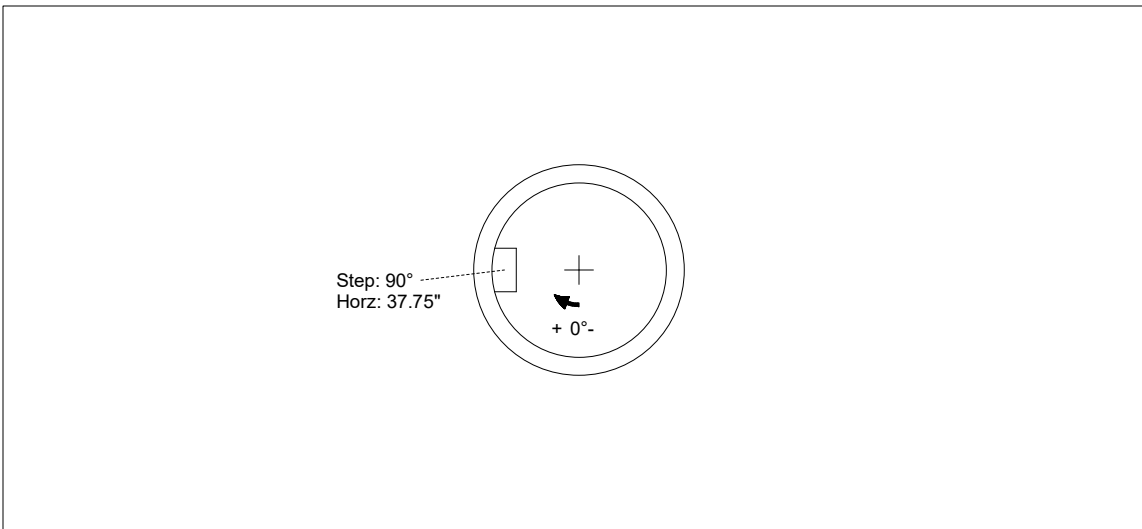
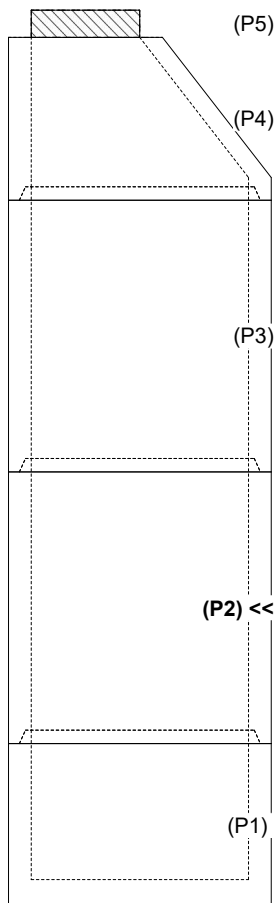

INSIDE WALL DIMENSIONS

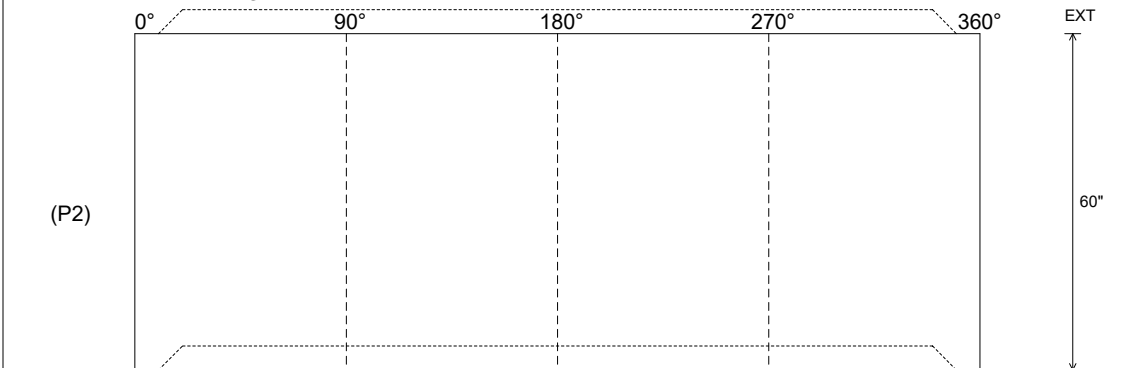

Coating (Int):
Coating (Ext):

Seam Up: Tongue
Seam Dn: Groove

Wall Thickness: 5"
Floor Height: 0"

Height (Int): 60"
Height (Ext): 60"

Weight (Net): 4192 lb
Volume (Net): 1.07cu.yd