

Job Name: 25-2422 - Woodland Springs Section 3 (Sanitary)  
 Job Location: Clarksville, TN  
 Contractor: Byard Construction, LLC

Plant: 100

5/14/2026 2:15:57 PM

Tech: Jared - A

PC: A. Chambers



**Structure ID: A-1**

**P1 MH048BA30CDARED**

**MH BASE w/ConBlock-CDA Red T/n**

P5) 24" - CASTING HEIGHT - 6"	0 lb
P4) 48" - ECC CONE w/ 24" HOLE, w/ConBlock-CDA Red F/G - 30"	1961 lb
P3) 48" - MH RISER w/ConBlock-CDA Red T/G - 72"	5030 lb
P2) 48" - MH RISER w/ConBlock-CDA Red T/G - 72"	5030 lb
P1) 48" - MH BASE w/ConBlock-CDA Red T/n - 30"	3330 lb
1) 48" - MH INVERT CHANNEL w/ConBlock-CDA Red - FULL HEIGHT	1440 lb
1) JOINT WRAP - 0.065"x6"x50" CONSEAL CS212	0 lb
1) JOINT WRAP PRIMER - CONSEAL CS-75 (1 gal.)	0 lb
1) ADMIXTURE CONBLOCK CDA RED	0 lb
1) CASTING - JBS 1155 F/C SANITARY	250 lb
3) 48" - Conseal CS-102 1.00" (Double)	0 lb
1) 24" - Conseal CS-102 1.00" (Double)	0 lb
2) PSX - 12-08 NYLO	16 lb
17) MH Step ML-10-TDS-NCR - 10"	0 lb
<b>Structure Total:</b>	<b>17057 lb</b>

**Structure Notes:**  
 1. PER ASTM C-478 SPECIFICATIONS  
 2. CONCRETE: 4,000 PSI AT 28 DAYS  
 3. REINFORCEMENT: PER ASTM A615  
 4. INVERT CHANNEL REQUIRED  
 5. CONBLOCK CDA RED ADMIXTURE REQUIRED  
 6. STEPS AT 135 DEGREES  
 7. JBS 1155 FRAME & COVER "SANITARY" SUPPLIED BY ICAST

Rim: 428.02' Rim to Invert: 17.38' Slack: 0.56" Sump: 2" Step Position: 135°

Position	Elev	Angle	Ext. (cw)	Pipe	Pipe OD	Connector	Hole	Horz Size	Up ( )	Offset
Invert 1	410.64'	0°	0"	8" PVC SDR26	8.5"	PSX 12-08 NYLO	12"	12.129"	0"	0"
Invert 2	410.74'	270°	136.625"	8" PVC SDR26	8.5"	PSX 12-08 NYLO	12"	12.129"	1.25"	0"
Invert 3										
Invert 4										
Invert 5										
Invert 6										
Invert 7										
Invert 8										

RIGHT-SIDE UP VIEW (int. dimensions)

UPSIDE-DOWN VIEW (int. dimensions)

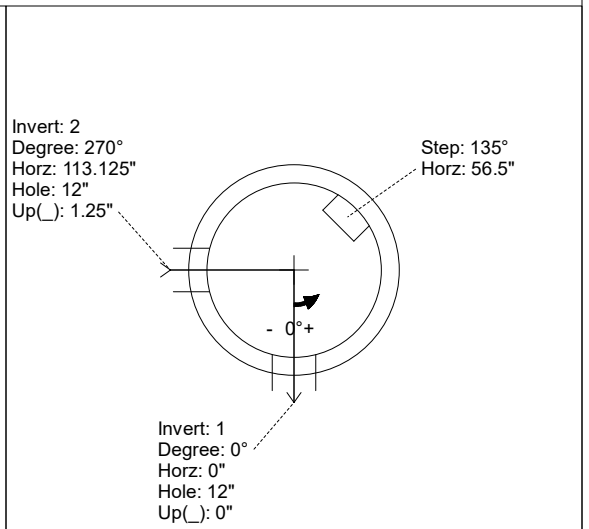
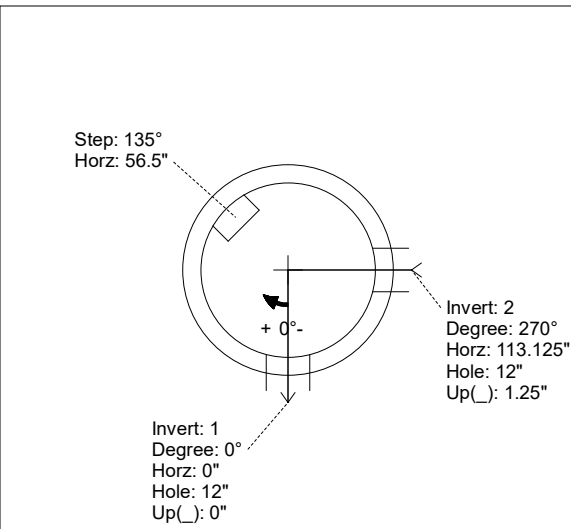
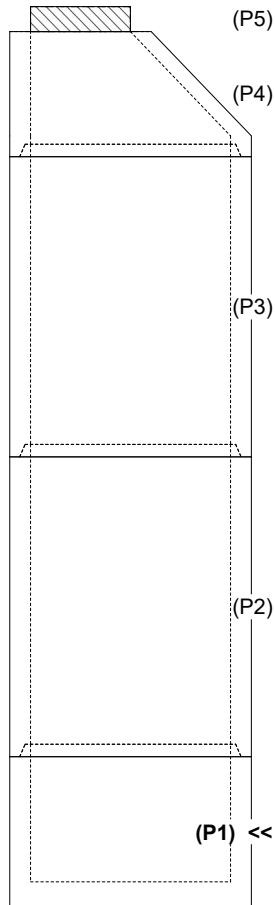

INSIDE WALL DIMENSIONS

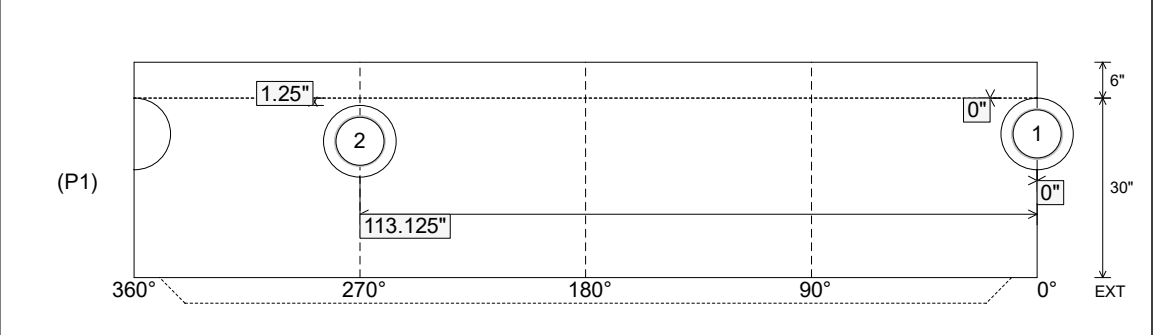

Coating (Int): Coating (Ext):	Seam Up: Tongue Seam Dn: n/a	Wall Thickness: 5" Floor Height: 6"	Height (Int): 30" Height (Ext): 36"	Weight (Net): 3330 lb Volume (Net): 0.85cu.yd
----------------------------------	---------------------------------	--	--	--

Job Name: 25-2422 - Woodland Springs Section 3 (Sanitary)  
 Job Location: Clarksville, TN  
 Contractor: Byard Construction, LLC

Plant: 100

5/14/2026 2:15:57 PM

Tech: Jared - A

PC: A. Chambers



**Structure ID: A-1**

**P1 MH048BA30CDARED**

**MH BASE w/ConBlock-CDA Red T/n**

- P5) 24" - CASTING HEIGHT - 6" 0 lb
- P4) 48" - ECC CONE w/ 24" HOLE, w/ConBlock-CDA Red F/G - 30" 1961 lb
- P3) 48" - MH RISER w/ConBlock-CDA Red T/G - 72" 5030 lb
- P2) 48" - MH RISER w/ConBlock-CDA Red T/G - 72" 5030 lb
- P1) 48" - MH BASE w/ConBlock-CDA Red T/n - 30" 3330 lb
- 1) 48" - MH INVERT CHANNEL w/ConBlock-CDA Red - FULL HEIGHT 1440 lb
- 1) JOINT WRAP - 0.065"x6"x50" CONSEAL CS212 0 lb
- 1) JOINT WRAP PRIMER - CONSEAL CS-75 (1 gal.) 0 lb
- 1) ADMIXTURE CONBLOCK CDA RED 0 lb
- 1) CASTING - JBS 1155 F/C SANITARY 250 lb
- 3) 48" - Conseal CS-102 1.00" (Double) 0 lb
- 1) 24" - Conseal CS-102 1.00" (Double) 0 lb
- 2) PSX - 12-08 NYLO 16 lb
- 17) MH Step ML-10-TDS-NCR - 10" 0 lb

- Structure Notes:**
1. PER ASTM C-478 SPECIFICATIONS
  2. CONCRETE: 4,000 PSI AT 28 DAYS
  3. REINFORCEMENT: PER ASTM A615
  4. INVERT CHANNEL REQUIRED
  5. CONBLOCK CDA RED ADMIXTURE REQUIRED
  6. STEPS AT 135 DEGREES
  7. JBS 1155 FRAME & COVER "SANITARY" SUPPLIED BY ICAST

Structure Total: 17057 lb

Rim: 428.02' Rim to Invert: 17.38' Slack: 0.56" Sump: 2" Step Position: 135°

Position	Elev	Angle	Ext. (cw)	Pipe	Pipe OD	Connector	Hole	Horz Size	Up ( )	Offset
Invert 1	410.64'	0°	0"	8" PVC SDR26	8.5"	PSX 12-08 NYLO	12"	12.129"	0"	0"
Invert 2	410.74'	270°	136.625"	8" PVC SDR26	8.5"	PSX 12-08 NYLO	12"	12.129"	1.25"	0"
Invert 3										
Invert 4										
Invert 5										
Invert 6										
Invert 7										
Invert 8										

RIGHT-SIDE UP VIEW (int. dimensions)

UPSIDE-DOWN VIEW (int. dimensions)

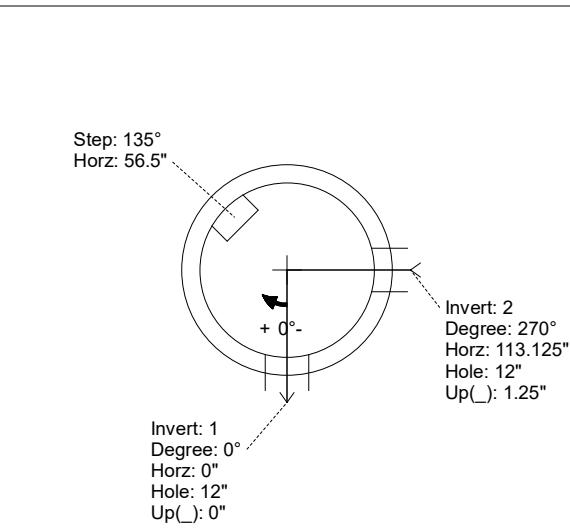
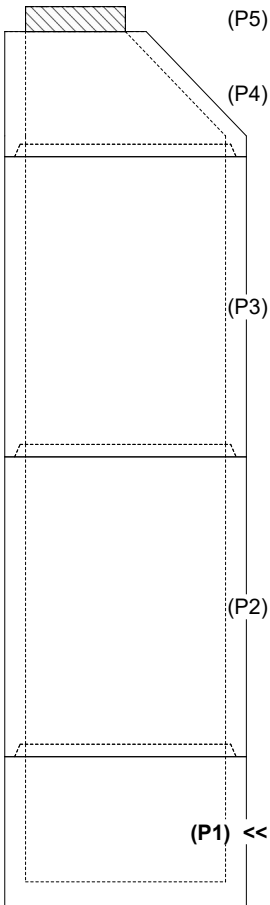

INVERT CHANNEL  
DRAWING

INSIDE WALL DIMENSIONS

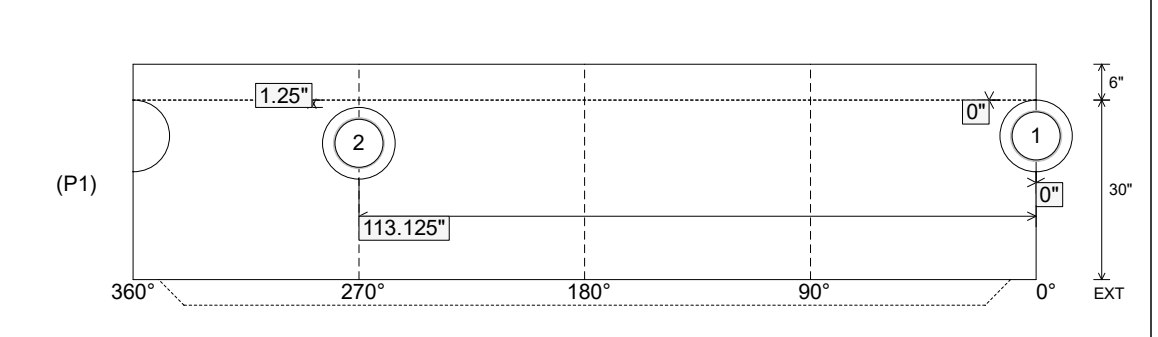

Coating (Int):  
Coating (Ext):

Seam Up: Tongue  
Seam Dn: n/a

Wall Thickness: 5"  
Floor Height: 6"

Height (Int): 30"  
Height (Ext): 36"

Weight (Net): 3330 lb  
Volume (Net): 0.85cu.yd