

Structure ID: 10-CS-6

P3 MH072RS24S

MH RISER NO STEPS T/G

P5) 30" - CASTING HEIGHT - 4" P4) 72" - MH FLAT TOP SPEC. (30" ECC HOLE) F/G - 15" P3) 72" - MH RISER NO STEPS T/G - 24" P2) 72" - MH RISER Custom Ht T/G - 63" P1) 72" - MH BASE Custom Ht T/n - 27" 1) ASSEMBLY REQUIRED 1) CVSTENCILING 3) 72" - Conseal CS-102 1.00" 2) Hole - 36	0 lb 4661 lb 3499 lb 7941 lb 7835 lb 0 lb 0 lb 0 lb 0 lb 0 lb	Structure Total: 23936 lb
---	--	---------------------------

Structure Notes:
 4" CASTING BY OTHERS

LIFTING ANCHORS TO BE INSTALLED ON THE OUTSIDE OF THE STRUCTURE

ICAST TO INSTALL THE INTERNALS

CONTECH'S LOGO AS WELL AS THE INLET AND OUTLET MUST BE STENCILED ONTO THE STRUCTURE

BASE & P2 RISER TO BE MECHANICALLY ATTACHED BEFORE INSTALL

Rim: 476.78' Rim to Invert: 6.27' Slack: 2.276" Sump: 60.036" Step Position:

Position	Elev	Angle	Ext. (cw)	Pipe	Pipe OD	Connector	Hole	Horz Size	Up ()	Offset
Invert 1	470.51'	270°	202.633"	24" RCP B WALL	30"	Hole 36	36"	37.699"	-40.964"	0"
Invert 2	470.51'	90°	67.544"	24" RCP B WALL	30"	Hole 36	36"	37.699"	-40.964"	0"
Invert 3										
Invert 4										
Invert 5										
Invert 6										
Invert 7										
Invert 8										

RIGHT-SIDE UP VIEW (int. dimensions)

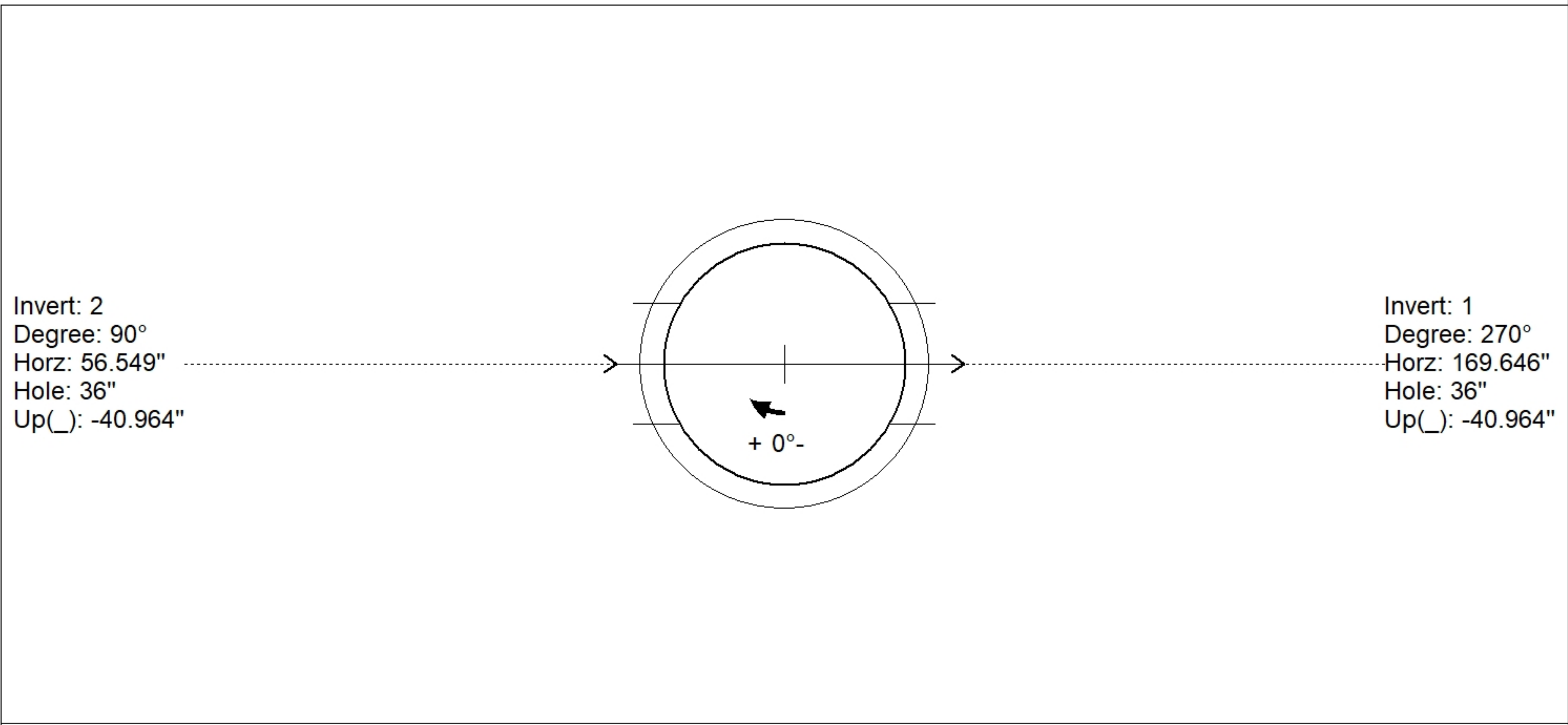
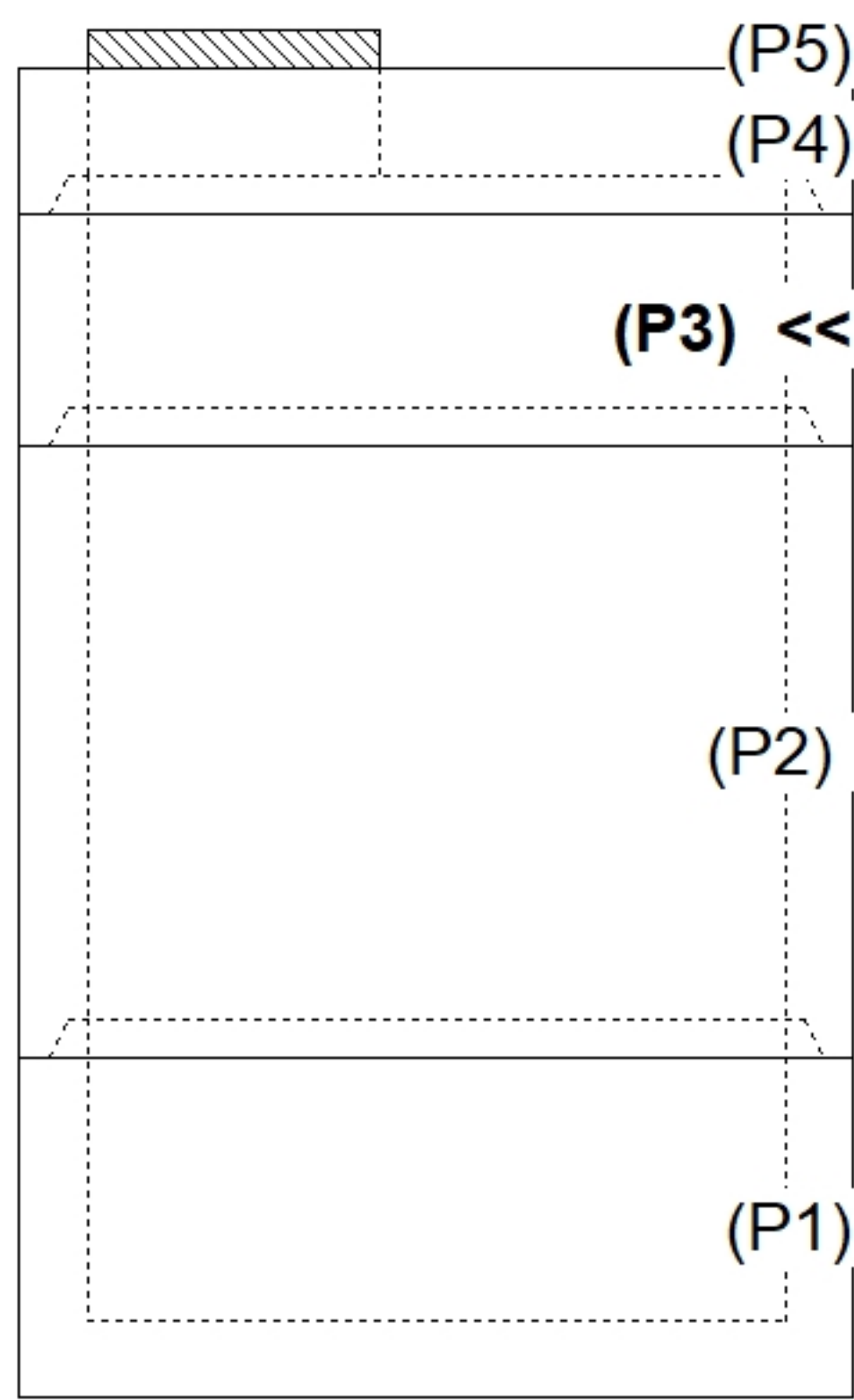

INSIDE WALL DIMENSIONS

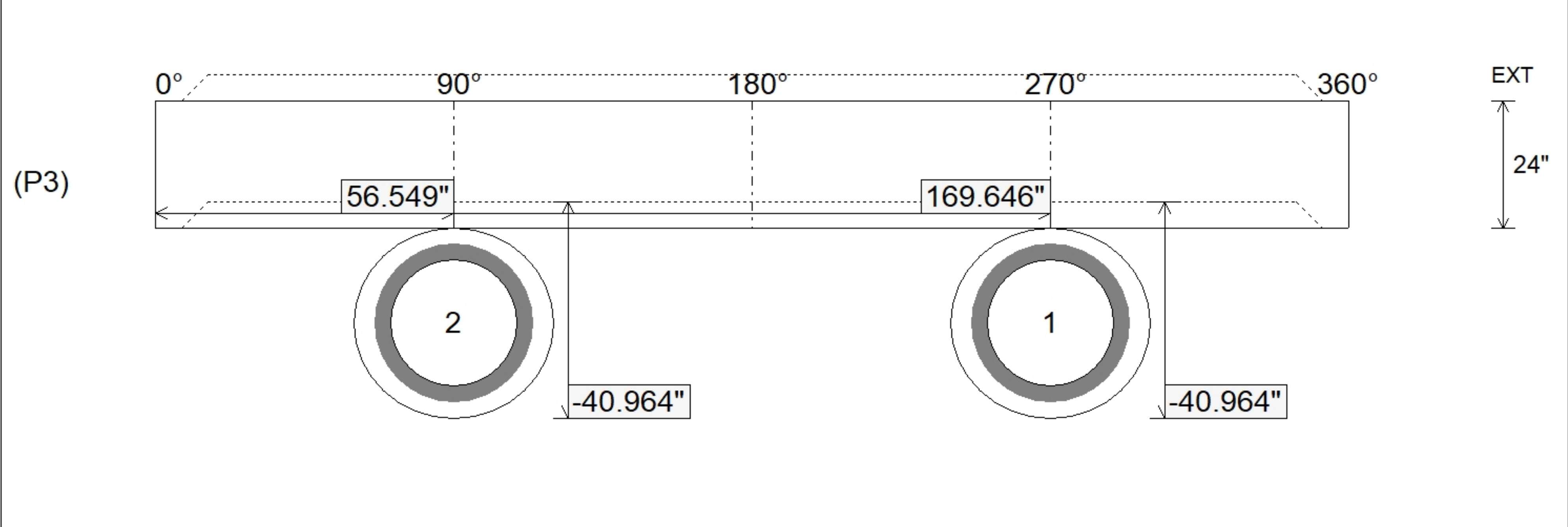

Coating (Int):	Seam Up: Tongue Seam Dn: Groove	Wall Thickness: 7" Floor Height: 0"	Height (Int): 24" Height (Ext): 24"
Coating (Ext):			Weight (Net): 3499 lb Volume (Net): 0.89cu.yd