

Structure ID: A1

P2 MH048RSVF

MH RISER Custom Ht T/G

P5) 24" x 24" - CASTING HEIGHT - 4" P4) 48" - MH FLAT TOP w/24"x24" Hole F/G - 12" P3) 48" - MH RISER SPECIAL T/G - 66" P2) 48" - MH RISER Custom Ht T/G - 41" P1) 48" - MH BASE T/n - 18" 1) JOINT WRAP - 0.065"x6"x50' CONSEAL CS212 1) JOINT WRAP PRIMER - CONSEAL CS-75 (1 gal.) 1) ASSEMBLY REQUIRED 1) CASTING - HOE 280T F/G 3) 48" - Conseal CS-102 1.00" (Double) 1) 24" x 24" - Conseal CS-102 1.00" (Double) 1) Hole - 26 1) Hole - 24	0 lb 1500 lb 4180 lb 2864 lb 2588 lb 0 lb 0 lb 0 lb 0 lb 182 lb 0 lb 0 lb 0 lb 0 lb	Structure Notes: 1. PER ASTM C478 SPECIFICATIONS. 2. CONCRETE = 4,000 PSI AT 28 DAYS. 3. NO INVERT CHANNEL. 4. CASTING BY ICAST (HOE 280T F/G). 5. P2 & P3 RISERS TO BE MECHANICALLY ATTACHED BEFORE INSTALL. 6. LIFTING ANCHORS TO BE INSTALLED ON THE OUTSIDE OF THE STRUCTURE. REINFORCING PER ASTM A615 (GRADE 60). - TOP SLAB (As .62) #5 BARS AT 6" C.C.E.W. - RISER/WALLS (As .12). - FLOOR (As .31) #5 BARS AT 12" C.C.E.W.
---	--	--

Structure Total: 11314 lb

Rim: 448.19' Rim to Invert: 5.04' Slack: 0.48" Sump: 81" Step Position:

Position	Elev	Angle	Ext. (cw)	Pipe	Pipe OD	Connector	Hole	Horz Size	Up ()	Offset
Invert 1										
Invert 2										
Invert 3										
Invert 4										
Invert 5										
Invert 6										
Invert 7										
Invert 8										

RIGHT-SIDE UP VIEW (int. dimensions)

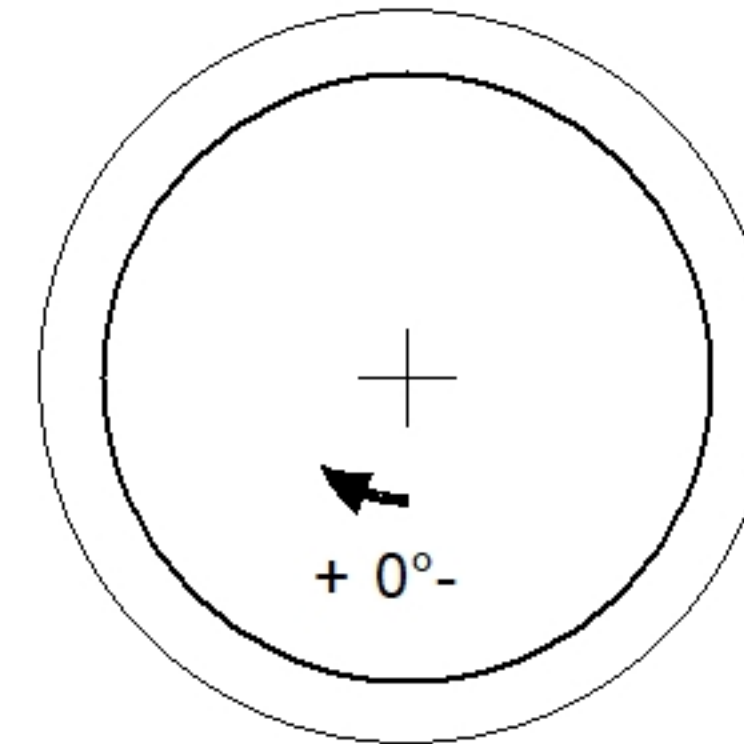

INSIDE WALL DIMENSIONS

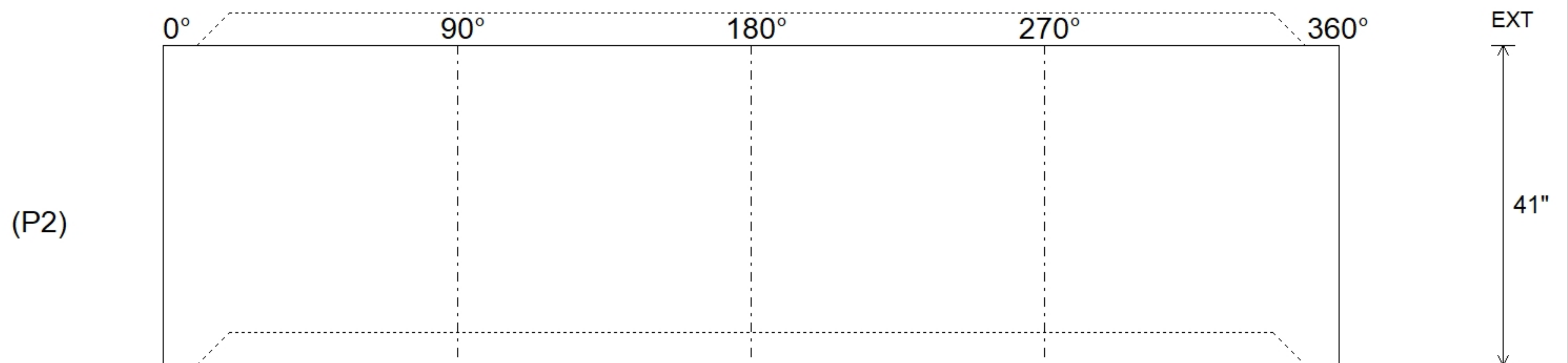

Coating (Int):	Seam Up: Tongue Seam Dn: Groove	Wall Thickness: 5" Floor Height: 0"	Height (Int): 41" Height (Ext): 41"
Coating (Ext):			Weight (Net): 2864 lb Volume (Net): 0.73cu.yd