

GENERAL NOTES:

1. MANUFACTURED TO ASTM C-913 (LATEST REVISION).
2. CONCRETE: 4,000 PSI AT 28 DAYS.
3. REINFORCING: #5 BAR @ 6" O.C.E.W. PER ASTM A615. (GRADE 60).
4. WEIGHT: 8,851 LBS
5. HATCH: HALLIDAY S2R 72" X 48" HATCH SUPPLIED BY OTHERS, TO BE CAST INTO TOP OF LID.
6. DOUBLE ROLL CS-102 JOINT SEALANT.

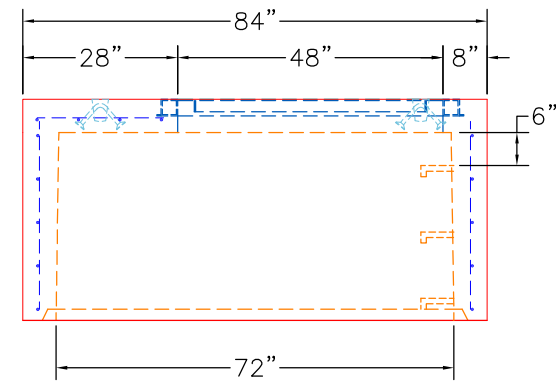
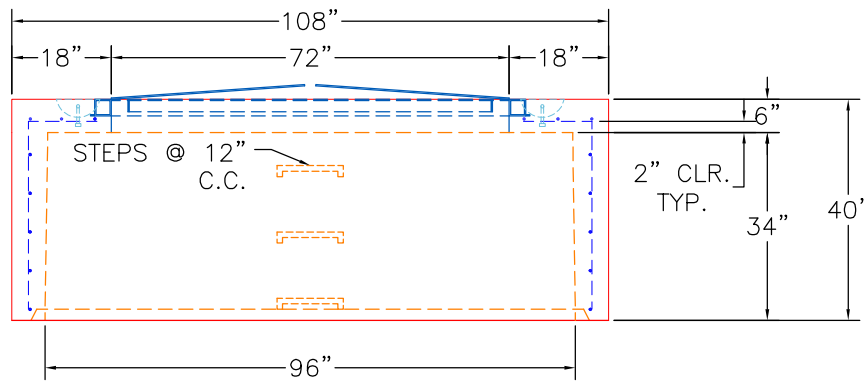

PRODUCTION WORK ORDER

PRODUCT I.D.: BX7296-06W06T-VF-MT

DESCRIPTION: 72" X 96" X 40" MONOTOP



QUALITY CONTROL CHECKLIST

- ALL DIMENSIONS CORRECT.
- LIFTERS INSTALLED.
- HATCH CORRECT LOCATION.
- REINFORCING CORRECT.
- SURFACE QUALITY ACCEPTABLE.
- EDGES CHAMFERED.
- ALL PATCHWORK ACCEPTABLE.

PRODUCT VIEW: RIGHT SIDE UP

CUSTOMER: CORE & MAIN

PLANT: BEAVER DAM, KY.

PROJECT: GLADEVILLE VAULT

WEIGHT: 8,851 LBS.

STRUCTURE: VAULT

TOP SECTION JOINT: N/A

ORDER NO: 26-2098

BASE SECTION JOINT: GROOVE

PC: C. GOFF

DRAWING: S. FELLETER

QC CHECK INITIALS:

DATE: 05/18/26

SCALE: NTS

PG. 1 of 1