

Job Name: 25-4733 - The Paddock  
 Job Location: Springfield, KY  
 Contractor: Core & Main LP (Lou)

Plant: 100  
 5/14/2026 1:08:53 PM

Tech: Jared - F  
 PC: T. Lewis



**Structure ID: SSWR-7**

**P1 MH048BA24**

**MH BASE T/n**

P3) 24" - CASTING HEIGHT - 7"	0 lb
P2) 48" - MH FLAT TOP w/ 24" ECC Hole F/G - 12"	1561 lb
P1) 48" - MH BASE T/n - 24"	2959 lb
1) JOINT WRAP - 0.065"x6"x50' CONSEAL CS212	0 lb
1) JOINT WRAP PRIMER - CONSEAL CS-75 (1 gal.)	0 lb
1) 48" - MH INVERT CHANNEL - FULL HEIGHT	1440 lb
1) CASTING - HOE MC-315 F/C Sanitary	258 lb
1) 48" - Conseal CS-102 1.00" (Double)	0 lb
1) PSX - 12M NYLO	8 lb
1) MH Step ML-10-TDS-NCR - 10"	0 lb
<b>Structure Total:</b>	<b>6226 lb</b>

**Structure Notes:**  
 1. PER ASTM C478 SPECIFICATIONS.  
 2. CONCRETE = 4,000 PSI AT 28 DAYS.  
 3. CASTING BY ICAST (HOE MC-315 F/C SANITARY).  
  
 REINFORCING PER ASTM A615 (GRADE 60).  
 - TOP SLAB = H2O LOADING.  
 - RISER/WALLS (As .12)  
 - FLOOR (As .31) #5 BARS AT 12" C.C.E.W.

Rim: 891.29' Rim to Invert: 3.53' Slack: 1.36" Sump: 2" Step Position: 180°

Position	Elev	Angle	Ext. (cw)	Pipe	Pipe OD	Connector	Hole	Horz Size	Up (⌋)	Offset
Invert 1	887.76'	0°	0"	8" PVC C900	9.05"	PSX 12M NYLO	12"	12.129"	0"	0"
Invert 2										
Invert 3										
Invert 4										
Invert 5										
Invert 6										
Invert 7										
Invert 8										

RIGHT-SIDE UP VIEW (int. dimensions)

UPSIDE-DOWN VIEW (int. dimensions)

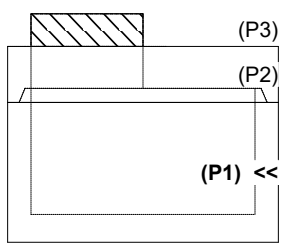
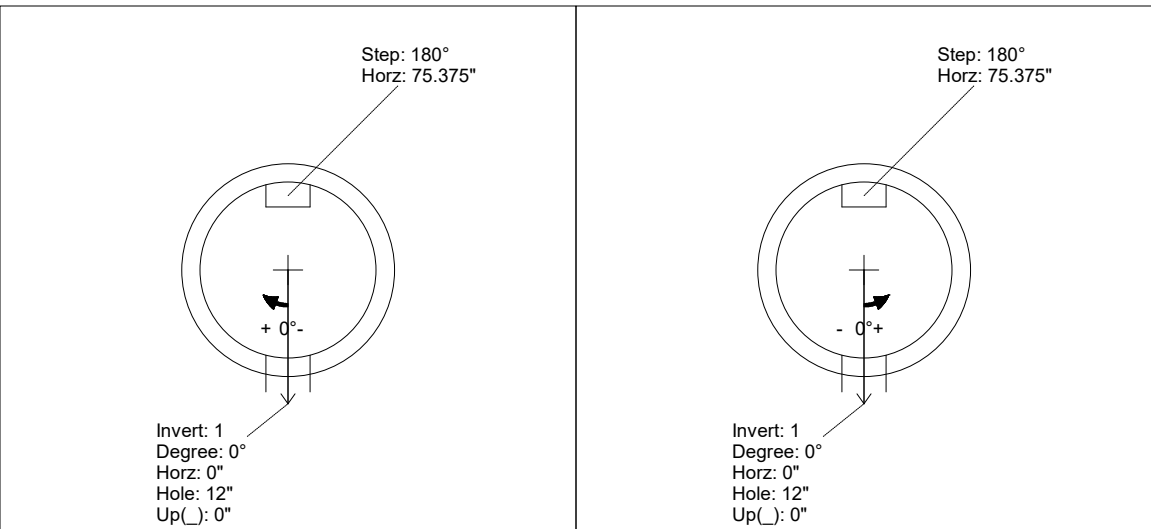

INSIDE WALL DIMENSIONS

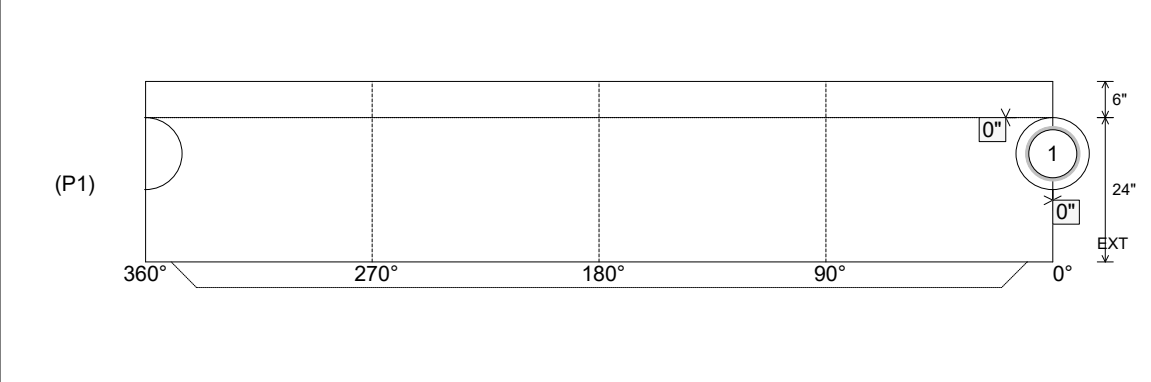

Coating (Int): Coating (Ext):	Seam Up: Tongue Seam Dn: n/a	Wall Thickness: 5" Floor Height: 6"	Height (Int): 24" Height (Ext): 30"	Weight (Net): 2959 lb Volume (Net): 0.76cu.yd
----------------------------------	---------------------------------	--	--	--

Job Name: 25-4733 - The Paddock  
 Job Location: Springfield, KY  
 Contractor: Core & Main LP (Lou)

Plant: 100  
 5/14/2026 1:08:53 PM

Tech: Jared - F  
 PC: T. Lewis



**Structure ID: SSWR-7**

**P1 MH048BA24**

**MH BASE T/n**

- P3) 24" - CASTING HEIGHT - 7"
- P2) 48" - MH FLAT TOP w/ 24" ECC Hole F/G - 12"
- P1) 48" - MH BASE T/n - 24"
- 1) JOINT WRAP - 0.065"x6"x50' CONSEAL CS212
- 1) JOINT WRAP PRIMER - CONSEAL CS-75 (1 gal.)
- 1) 48" - MH INVERT CHANNEL - FULL HEIGHT
- 1) CASTING - HOE MC-315 F/C Sanitary
- 1) 48" - Conseal CS-102 1.00" (Double)
- 1) PSX - 12M NYLO
- 1) MH Step ML-10-TDS-NCR - 10"

0 lb  
 1561 lb  
 2959 lb  
 0 lb  
 0 lb  
 1440 lb  
 258 lb  
 0 lb  
 8 lb  
 0 lb  
 -----  
 Structure Total: 6226 lb

**Structure Notes:**  
 1. PER ASTM C478 SPECIFICATIONS.  
 2. CONCRETE = 4,000 PSI AT 28 DAYS.  
 3. CASTING BY ICAST (HOE MC-315 F/C SANITARY).  
 REINFORCING PER ASTM A615 (GRADE 60).  
 - TOP SLAB = H2O LOADING.  
 - RISER/WALLS (As .12)  
 - FLOOR (As .31) #5 BARS AT 12" C.C.E.W.

Rim: 891.29' Rim to Invert: 3.53' Slack: 1.36" Sump: 2" Step Position: 180°

Position	Elev	Angle	Ext. (cw)	Pipe	Pipe OD	Connector	Hole	Horz Size	Up (⌋)	Offset
Invert 1	887.76'	0°	0"	8" PVC C900	9.05"	PSX 12M NYLO	12"	12.129"	0"	0"
Invert 2										
Invert 3										
Invert 4										
Invert 5										
Invert 6										
Invert 7										
Invert 8										

RIGHT-SIDE UP VIEW (int. dimensions)

UPSIDE-DOWN VIEW (int. dimensions)

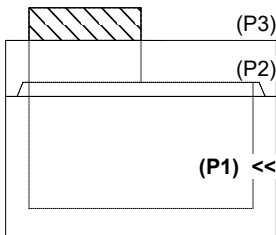
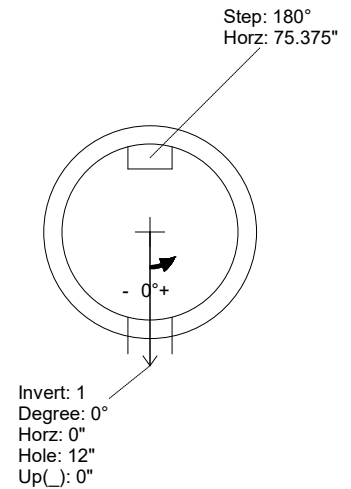
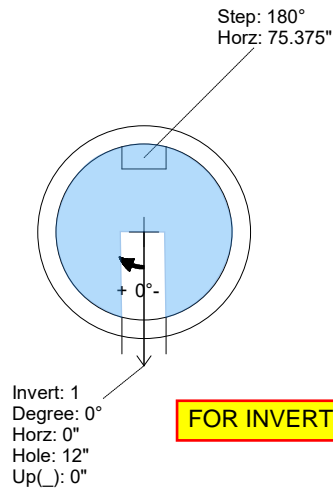

INSIDE WALL DIMENSIONS

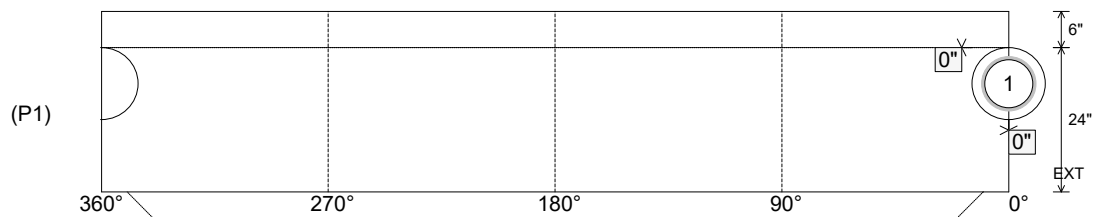

Coating (Int):  
 Coating (Ext):

Seam Up: Tongue  
 Seam Dn: n/a

Wall Thickness: 5"  
 Floor Height: 6"

Height (Int): 24"  
 Height (Ext): 30"

Weight (Net): 2959 lb  
 Volume (Net): 0.76cu.yd