

Job Name: 25-3452 - Churchill Downs Skye Terrace Improvements
 Job Location: Louisville, KY 40208
 Contractor: Louisville Paving and Construction

Plant: 100
 4/30/2026 1:21:52 PM

Tech: Jared - F
 PC: J. Jarvis



Structure ID: S211

P1 MH060BAVF

MH BASE Custom Ht T/n

P4) 32" x 32" - CASTING HEIGHT - 3"	0 lb
P3) 60" - MH FLAT TOP w/32"x32" Hole F/G - 13"	2369 lb
P2) 60" - MH RISER T/G - 18"	1854 lb
P1) 60" - MH BASE Custom Ht T/n - 64"	8514 lb
1) CASTING - HOE 595 F/G	376 lb
2) 60" - Conseal CS-102 1.00"	0 lb
1) 32" x 32" - Conseal CS-102 1.00"	0 lb
2) Hole - 30	0 lb
1) Hole - 20	0 lb
1) Hole - 8	0 lb
Structure Total:	13112 lb

Structure Notes:
 1. PER ASTM C478 SPECIFICATIONS.
 2. CONCRETE = 4,000 PSI AT 28 DAYS.
 3. NO STEPS AND NO INVERT CHANNEL.
 4. CASTING BY ICAST (HOE 595 F/G)

REINFORCING PER ASTM A615 (GRADE 60).
 - TOP SLAB (As .62) #5 BARS AT 6" C.C.E.W..
 - RISER/WALLS (As .18)
 - FLOOR (As .37) #5 BARS AT 10" C.C.E.W.

Rim: 454.52' Rim to Invert: 8.48' Slack: 3.76" Sump: 0" Step Position:

Position	Elev	Angle	Ext. (cw)	Pipe	Pipe OD	Connector	Hole	Horz Size	Up ()	Offset
Invert 1	446.04'	0°	0"	24" HDPE	27.8"	Hole 30	30"	31.416"	-1.875"	0"
Invert 2	446.04'	182°	114.375"	24" HDPE	27.8"	Hole 30	30"	31.416"	-1.875"	0"
Invert 3	447.16'	273°	171.5"	15" HDPE	17.6"	Hole 20	20"	20.39"	12.125"	0"
Invert 4										
Invert 5										
Invert 6										
Invert 7										
Invert 8										

RIGHT-SIDE UP VIEW (int. dimensions)

UPSIDE-DOWN VIEW (int. dimensions)

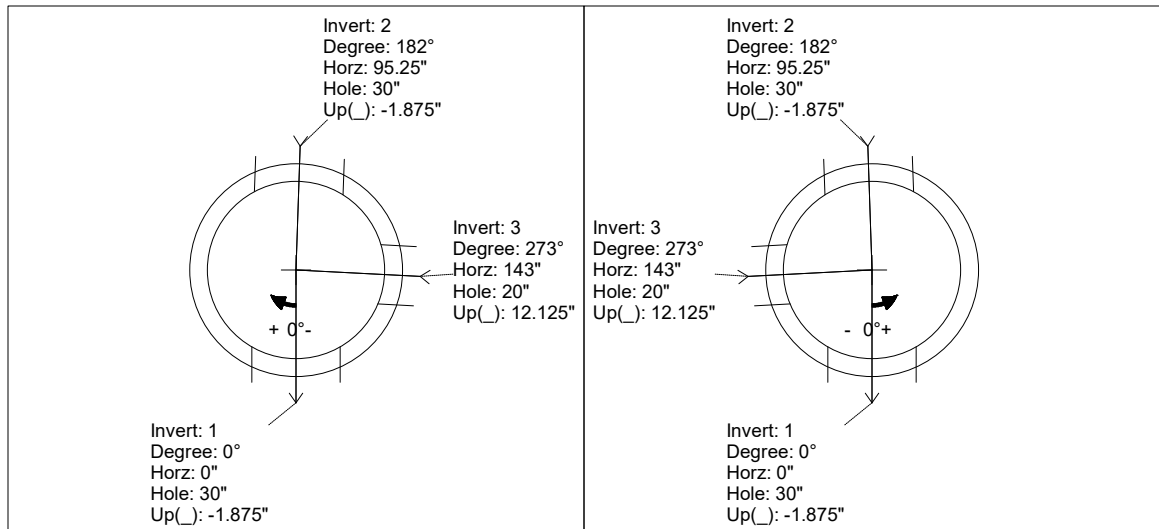
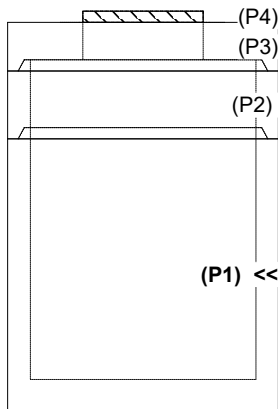

INSIDE WALL DIMENSIONS

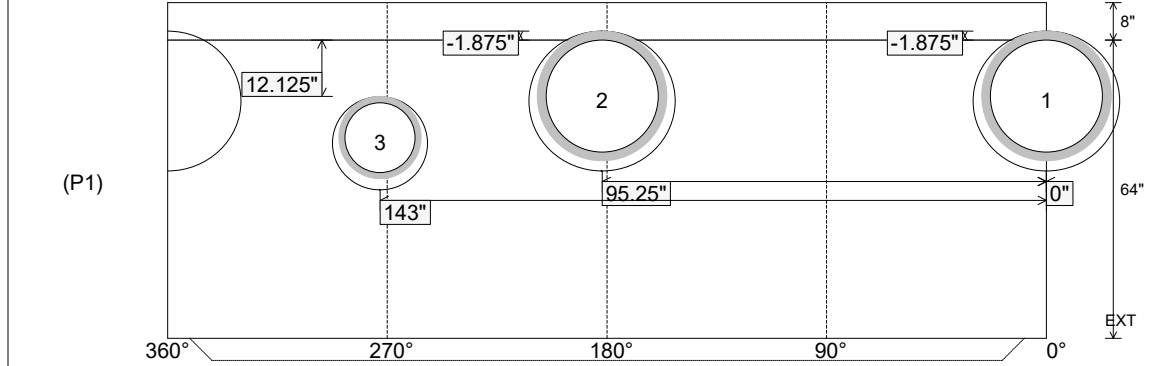

Coating (Int): Coating (Ext):	Seam Up: Tongue Seam Dn: n/a	Wall Thickness: 6" Floor Height: 8"	Height (Int): 64" Height (Ext): 72"	Weight (Net): 8514 lb Volume (Net): 2.17cu.yd
----------------------------------	---------------------------------	--	--	--