

Job Name: 25-3452 - Churchill Downs Skye Terrace Improvements
 Job Location: Louisville, KY 40208
 Contractor: Louisville Paving and Construction

Plant: 100
 4/30/2026 1:21:49 PM

Tech: Jared - F
 PC: J. Jarvis



Structure ID: S207

P1 MH048BAVF

MH BASE Custom Ht T/n

- P3) 24" - CASTING HEIGHT - 7"
- P2) 48" - ECC CONE w/ 24" HOLE F/G - 36"
- P1) 48" - MH BASE Custom Ht T/n - 53"
- 1) CASTING - HOE MC-420 F/C Storm
- 1) 48" - Conseal CS-102 1.00"
- 1) Hole - 30
- 1) Hole - 20
- 1) Hole - 16
- 7) MH Step ML-10-TDS-NCR - 10"

0 lb
 3000 lb
 4496 lb
 340 lb
 0 lb
 0 lb
 0 lb
 0 lb
 0 lb
 0 lb
 Structure Total: 7836 lb

Structure Notes:
 1. PER ASTM C478 SPECIFICATIONS.
 2. CONCRETE = 4,000 PSI AT 28 DAYS.
 3. NO INVERT CHANNEL.
 4. CASTING BY ICAST (HOE MC-420 F/C STORM)

REINFORCING PER ASTM A615 (GRADE 60).
 - CONE (As .12)
 - RISER/WALLS (As .12)
 - FLOOR (As .31) #5 BARS AT 12" C.C.E.W.

Rim: 454.81' Rim to Invert: 8.05' Slack: 0.6" Sump: 0" Step Position: 90°

Position	Elev	Angle	Ext. (cw)	Pipe	Pipe OD	Connector	Hole	Horz Size	Up ()	Offset
Invert 1	446.76'	0°	0"	24" HDPE	27.8"	Hole 30	30"	32.406"	-1.875"	0"
Invert 2	449.19'	190°	96.125"	15" HDPE	17.6"	Hole 20	20"	20.629"	27.875"	0"
Invert 3	447.26'	277°	140.25"	12" HDPE	14.5"	Hole 16	16"	16.312"	4.75"	0"
Invert 4										
Invert 5										
Invert 6										
Invert 7										
Invert 8										

RIGHT-SIDE UP VIEW (int. dimensions)

UPSIDE-DOWN VIEW (int. dimensions)

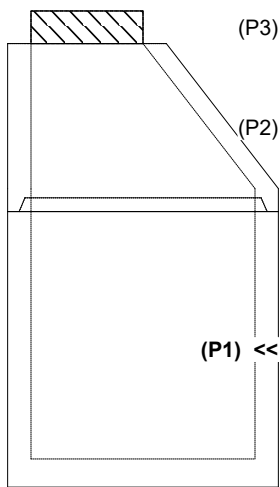
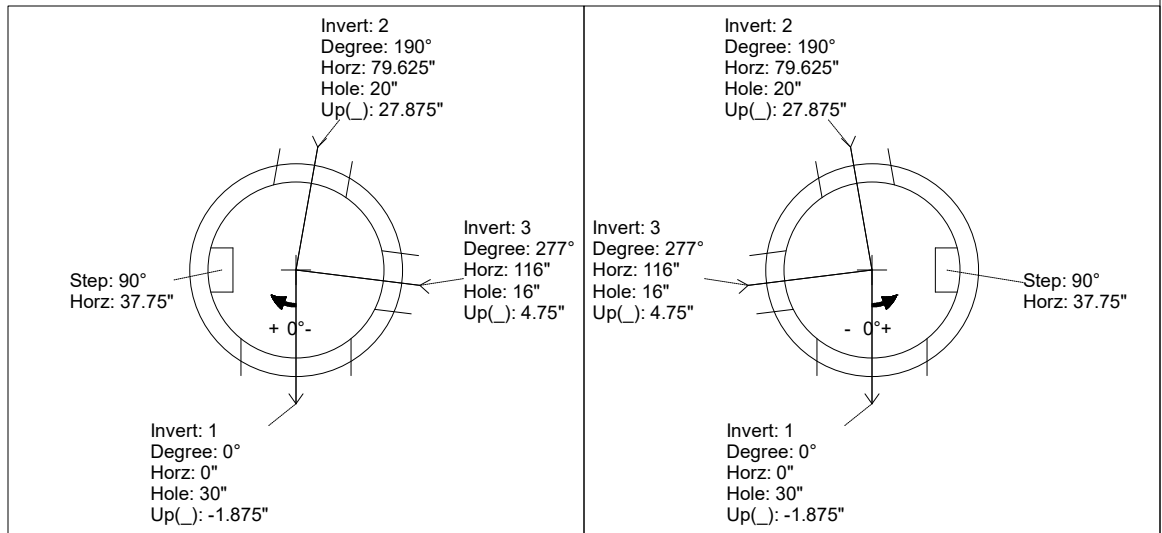

INSIDE WALL DIMENSIONS

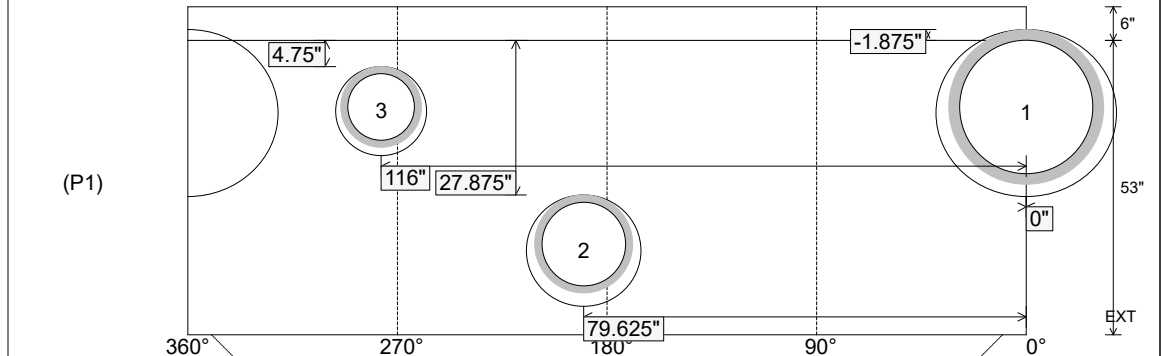

Coating (Int): Coating (Ext):	Seam Up: Tongue Seam Dn: n/a	Wall Thickness: 5" Floor Height: 6"	Height (Int): 53" Height (Ext): 59"	Weight (Net): 4496 lb Volume (Net): 1.15cu.yd
----------------------------------	---------------------------------	--	--	--