

Job Name: 25-3310 - Mammoth Cave NP-MACA 12
 Job Location: Mammoth Cave , KY
 Contractor: Phillips Brothers

Plant: 100

Tech: J. Horsley - F

5/5/2026 5:08:03 PM

PC: C. Goff



Structure ID: CB26B

P1 BX3048-08W08F-BAVF

BOX BASE 8inW, 8inF, Variable Ht F/n

- P2) 30" x 48" - CASTING HEIGHT - 8"
- P1) 30" x 48" - BOX BASE 8inW, 8inF, Variable Ht - 37"
- 1) SECONDARY POUR - WALLS
- 1) 30" x 48" - Conseal CS-102 1.00"
- 1) Hole - 24
- 2) Hole - 26

0 lb
 5482 lb
 0 lb
 0 lb
 0 lb
 0 lb
 0 lb

Structure Total: 5482 lb

Structure Notes:

1. PER ASTM C913 SPECIFICATIONS.
2. CONCRETE = 4,000 PSI AT 28 DAYS.
3. NO INVERT CHANNEL.
4. CASTING SUPPLIED BY OTHERS - NEENAH R-3287-15

REINFORCING PER ASTM A615 (GRADE 60).
 - WALLS (As .12) #5 BARS AT 6" C.C.E.W.
 - FLOOR (As .12) #5 BARS AT 6" C.C.E.W.

Rim: 737.71' Rim to Invert: 3.79' Slack: 0.48" Sump: 0" Step Position:

Position	Elev	Angle	Ext. (cw)	Pipe	Pipe OD	Connector	Hole	Horz Size	Up ()	Offset
Invert 1	733.92'	0°	23"	18" HDPE	21.2"	Hole 24	24"	24"	-1.625"	0"
Invert 2	733.92'	90°	32"	18" RCP B WALL	23"	Hole 26	26"	26"	-2.5"	0"
Invert 3	733.92'	225°	23.125"	18" RCP B WALL	23"	Hole 26	26"	36.77"	-2.5"	10"
Invert 4										
Invert 5										
Invert 6										
Invert 7										
Invert 8										

RIGHT-SIDE UP VIEW (int. dimensions)

UPSIDE-DOWN VIEW (int. dimensions)

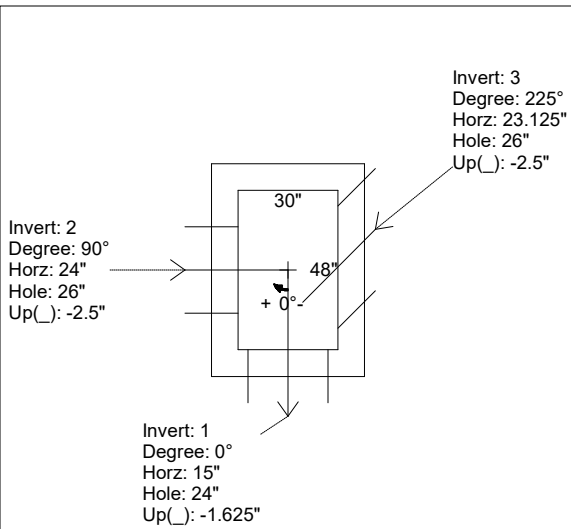

**1ST POUR (FLOOR) = 1,976 LBS
 2ND POUR (WALLS) = 3,506 LBS**

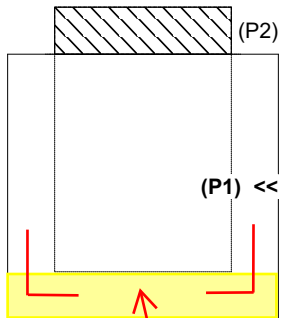

**1ST POUR (FLOOR)
 STUB #5 L BARS OUT
 TOP FLOOR, SPA AT
 12" C/C FOR
 CONNECTING WALLS**

INSIDE WALL DIMENSIONS

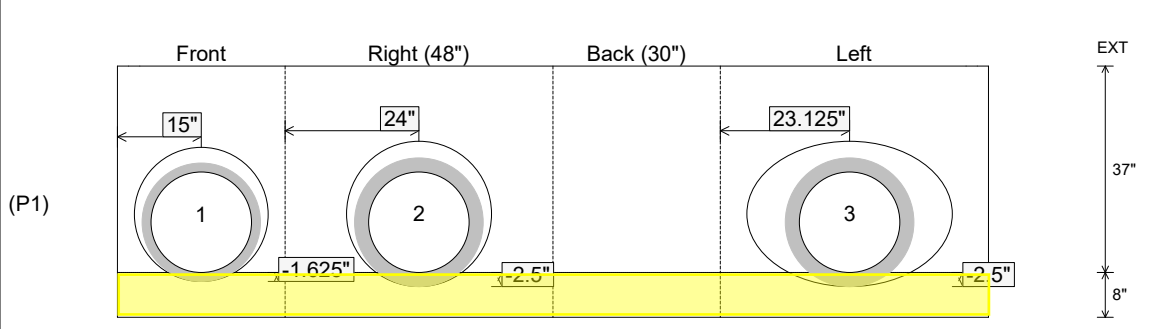

Coating (Int): Coating (Ext):	Seam Up: Flat Seam Dn: n/a	Wall Thickness: 8" Floor Height: 8"	Height (Int): 37" Height (Ext): 45"	Weight (Net): 5482 lb Volume (Net): 1.4cu.yd
----------------------------------	-------------------------------	--	--	---

Job Name: 25-3310 - Mammoth Cave NP-MACA 12
 Job Location: Mammoth Cave , KY
 Contractor: Phillips Brothers

Plant: 100
 5/5/2026 5:08:03 PM

Tech: J. Horsley - F
 PC: C. Goff



Structure ID: CB26B

P1 BX3048-08W08F-BAVF

BOX BASE 8inW, 8inF, Variable Ht F/n

- P2) 30" x 48" - CASTING HEIGHT - 8"
- P1) 30" x 48" - BOX BASE 8inW, 8inF, Variable Ht - 37"
- 1) SECONDARY POUR - WALLS
- 1) 30" x 48" - Conseal CS-102 1.00"
- 1) Hole - 24
- 2) Hole - 26

0 lb
 5482 lb
 0 lb
 0 lb
 0 lb
 0 lb
 0 lb

 Structure Total: 5482 lb

Structure Notes:
 1. PER ASTM C913 SPECIFICATIONS.
 2. CONCRETE = 4,000 PSI AT 28 DAYS.
 3. NO INVERT CHANNEL.
 4. CASTING SUPPLIED BY OTHERS - NEENAH R-3287-15

REINFORCING PER ASTM A615 (GRADE 60).
 - WALLS (As .12) #5 BARS AT 6" C.C.E.W.
 - FLOOR (As .12) #5 BARS AT 6" C.C.E.W.

Rim: 737.71' Rim to Invert: 3.79' Slack: 0.48" Sump: 0" Step Position:

Position	Elev	Angle	Ext. (cw)	Pipe	Pipe OD	Connector	Hole	Horz Size	Up ()	Offset
Invert 1	733.92'	0°	23"	18" HDPE	21.2"	Hole 24	24"	24"	-1.625"	0"
Invert 2	733.92'	90°	32"	18" RCP B WALL	23"	Hole 26	26"	26"	-2.5"	0"
Invert 3	733.92'	225°	23.125"	18" RCP B WALL	23"	Hole 26	26"	36.77"	-2.5"	10"
Invert 4										
Invert 5										
Invert 6										
Invert 7										
Invert 8										

RIGHT-SIDE UP VIEW (int. dimensions)

UPSIDE-DOWN VIEW (int. dimensions)

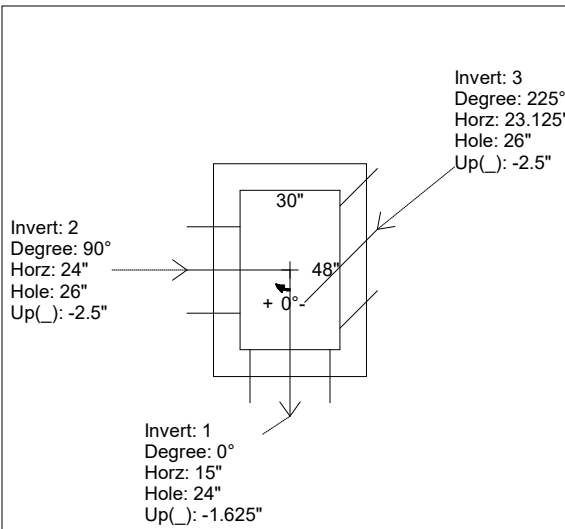

**1ST POUR (FLOOR) = 1,976 LBS
 2ND POUR (WALLS) = 3,506 LBS**

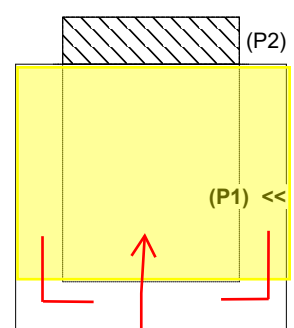

2ND POUR (WALLS)

INSIDE WALL DIMENSIONS

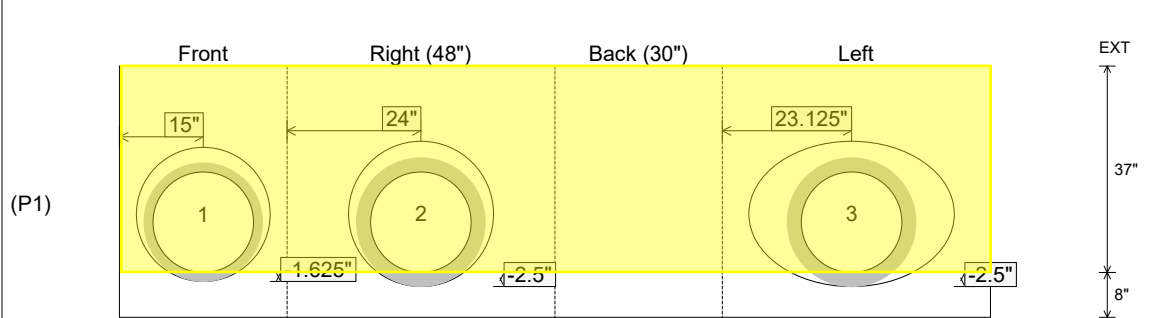

Coating (Int):
 Coating (Ext):

Seam Up: Flat
 Seam Dn: n/a

Wall Thickness: 8"
 Floor Height: 8"

Height (Int): 37"
 Height (Ext): 45"

Weight (Net): 5482 lb
 Volume (Net): 1.4cu.yd