

Job Name: 25-4733 - The Paddock
 Job Location: Springfield, KY
 Contractor: Core & Main LP (Lou)

Plant: 100

5/14/2026 11:30:48 AM

Tech: Jared - F

PC: T. Lewis



Structure ID: SSWR-3

P1 MH048BA24

MH BASE T/n

- P4) 24" - CASTING HEIGHT - 7"
- P3) 48" - ECC CONE w/ 24" HOLE F/G - 30"
- P2) 48" - MH RISER T/G - 36"
- P1) 48" - MH BASE T/n - 24"
- 1) JOINT WRAP - 0.065"x6"x50' CONSEAL CS212
- 1) JOINT WRAP PRIMER - CONSEAL CS-75 (1 gal.)
- 1) 48" - MH INVERT CHANNEL - FULL HEIGHT
- 1) CASTING - HOE MC-315 F/C Sanitary
- 2) 48" - Conseal CS-102 1.00" (Double)
- 2) PSX - 12M NYLO
- 1) PSX - 12-06 NYLO
- 7) MH Step ML-10-TDS-NCR - 10"

0 lb
 2050 lb
 2515 lb
 2863 lb
 0 lb
 0 lb
 1440 lb
 258 lb
 0 lb
 16 lb
 8 lb
 0 lb

 Structure Total: 9150 lb

Structure Notes:
 1. PER ASTM C478 SPECIFICATIONS.
 2. CONCRETE = 4,000 PSI AT 28 DAYS.
 3. CASTING BY ICAST (HOE MC-315 F/C SANITARY).

 REINFORCING PER ASTM A615 (GRADE 60).
 - CONE (As .12)
 - RISER/WALLS (As .12)
 - FLOOR (As .31) #5 BARS AT 12" C.C.E.W.

Rim: 888.08' Rim to Invert: 7.96' Slack: 0.52' Sump: 2' Step Position: 160°

Position	Elev	Angle	Ext. (cw)	Pipe	Pipe OD	Connector	Hole	Horz Size	Up ()	Offset
Invert 1	880.12'	0°	0"	8" PVC C900	9.05"	PSX 12M NYLO	12"	12.129"	0"	0"
Invert 2	880.22'	90°	45.5"	8" PVC C900	9.05"	PSX 12M NYLO	12"	12.129"	1.25"	0"
Invert 3	880.22'	235°	119"	6" PVC C900	6.9"	PSX 12-06 NYLO	12"	12.129"	0.25"	0"
Invert 4										
Invert 5										
Invert 6										
Invert 7										
Invert 8										

RIGHT-SIDE UP VIEW (int. dimensions)

UPSIDE-DOWN VIEW (int. dimensions)

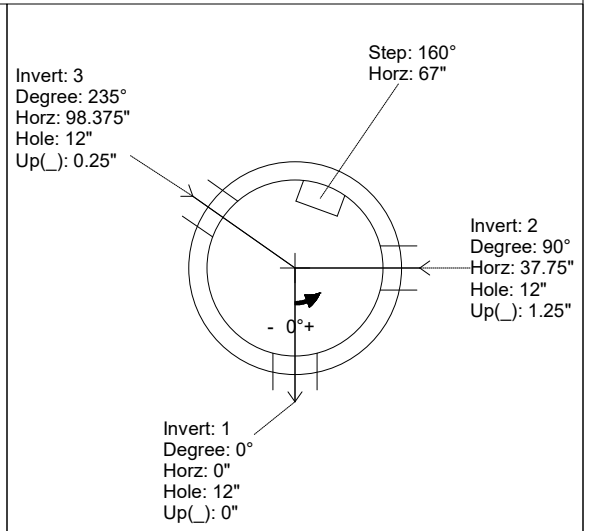
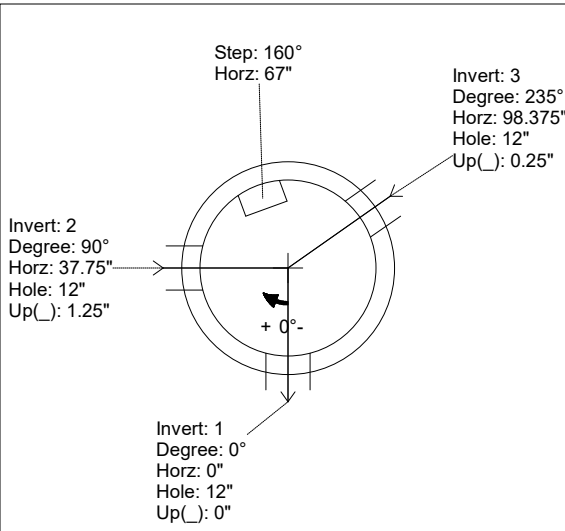
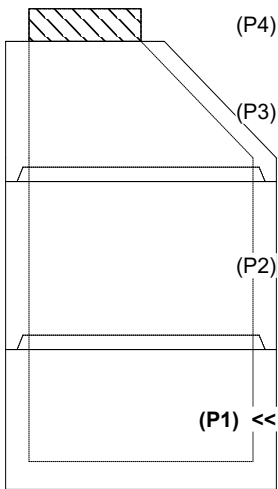

INSIDE WALL DIMENSIONS

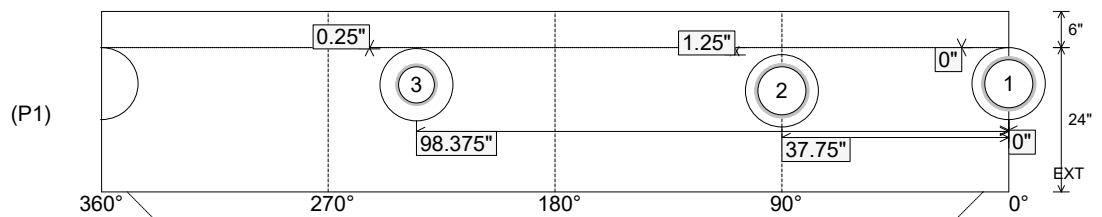

Coating (Int):
 Coating (Ext):

Seam Up: Tongue
 Seam Dn: n/a

Wall Thickness: 5"
 Floor Height: 6"

Height (Int): 24"
 Height (Ext): 30"

Weight (Net): 2863 lb
 Volume (Net): 0.73cu.yd

Job Name: 25-4733 - The Paddock
 Job Location: Springfield, KY
 Contractor: Core & Main LP (Lou)

Plant: 100

5/14/2026 11:30:48 AM

Tech: Jared - F

PC: T. Lewis



Structure ID: SSWR-3

P1 MH048BA24

MH BASE T/n

- P4) 24" - CASTING HEIGHT - 7"
- P3) 48" - ECC CONE w/ 24" HOLE F/G - 30"
- P2) 48" - MH RISER T/G - 36"
- P1) 48" - MH BASE T/n - 24"
- 1) JOINT WRAP - 0.065"x6"x50' CONSEAL CS212
- 1) JOINT WRAP PRIMER - CONSEAL CS-75 (1 gal.)
- 1) 48" - MH INVERT CHANNEL - FULL HEIGHT
- 1) CASTING - HOE MC-315 F/C Sanitary
- 2) 48" - Conseal CS-102 1.00" (Double)
- 2) PSX - 12M NYLO
- 1) PSX - 12-06 NYLO
- 7) MH Step ML-10-TDS-NCR - 10"

0 lb
 2050 lb
 2515 lb
 2863 lb
 0 lb
 0 lb
 1440 lb
 258 lb
 0 lb
 16 lb
 8 lb
 0 lb

 Structure Total: 9150 lb

Structure Notes:
 1. PER ASTM C478 SPECIFICATIONS.
 2. CONCRETE = 4,000 PSI AT 28 DAYS.
 3. CASTING BY ICAST (HOE MC-315 F/C SANITARY).

 REINFORCING PER ASTM A615 (GRADE 60).
 - CONE (As .12)
 - RISER/WALLS (As .12)
 - FLOOR (As .31) #5 BARS AT 12" C.C.E.W.

Rim: 888.08' Rim to Invert: 7.96' Slack: 0.52" Sump: 2" Step Position: 160°

Position	Elev	Angle	Ext. (cw)	Pipe	Pipe OD	Connector	Hole	Horz Size	Up ()	Offset
Invert 1	880.12'	0°	0"	8" PVC C900	9.05"	PSX 12M NYLO	12"	12.129"	0"	0"
Invert 2	880.22'	90°	45.5"	8" PVC C900	9.05"	PSX 12M NYLO	12"	12.129"	1.25"	0"
Invert 3	880.22'	235°	119"	6" PVC C900	6.9"	PSX 12-06 NYLO	12"	12.129"	0.25"	0"
Invert 4										
Invert 5										
Invert 6										
Invert 7										
Invert 8										

RIGHT-SIDE UP VIEW (int. dimensions)

UPSIDE-DOWN VIEW (int. dimensions)

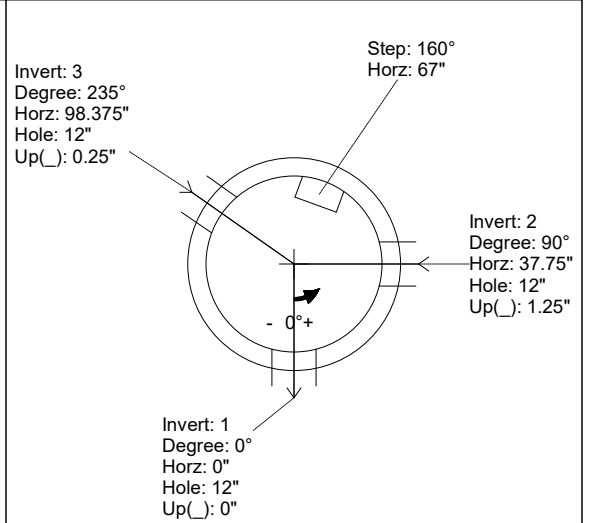
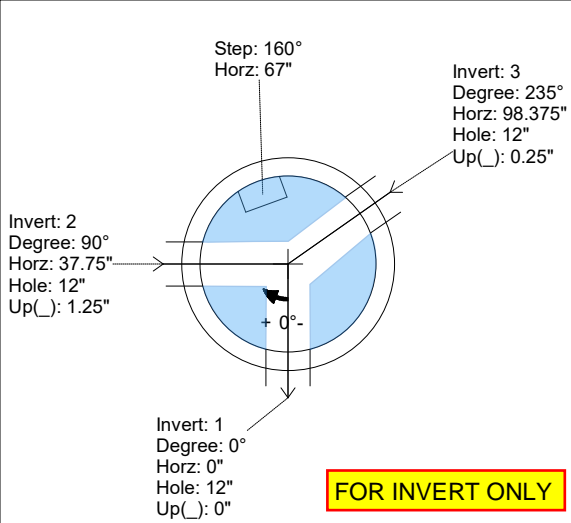

INSIDE WALL DIMENSIONS

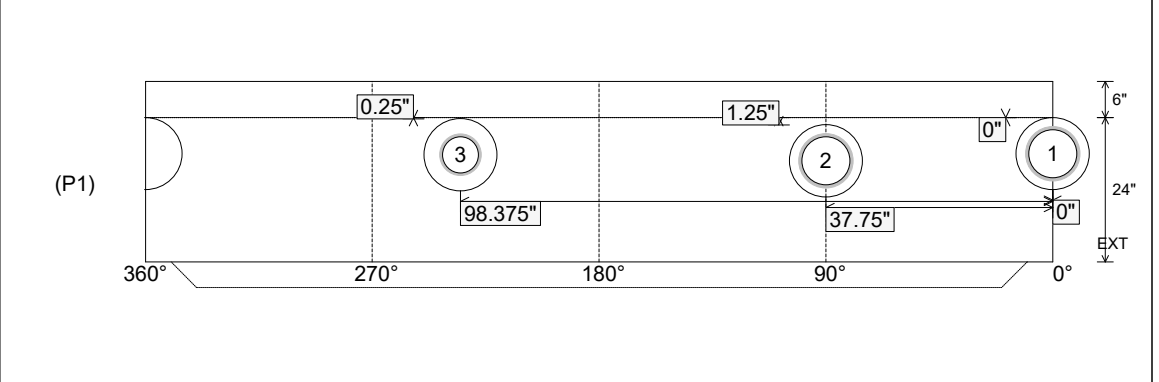

Coating (Int): Coating (Ext):	Seam Up: Tongue Seam Dn: n/a	Wall Thickness: 5" Floor Height: 6"	Height (Int): 24" Height (Ext): 30"	Weight (Net): 2863 lb Volume (Net): 0.73cu.yd
----------------------------------	---------------------------------	--	--	--