

Job Name: 25-3600 Signet FCU
 Job Location: Paducah, KY
 Contractor: Ainsworth Land Development, LLC

Plant: Beaver Dam
 5/8/2026 8:06:41 AM

Tech: S. Felletter
 PC: T. Lewis



Structure ID: JB1

P2 BXLD2424FL-24

BX FLAT LID 8inW SPEC. (KY JB-B1) F/F

- P3) CASTING (cast in) - 0
- P2) 24" x 24" - BX FLAT LID 8inW SPEC. (KY JB-B1) F/F - 8"
- P1) 24" x 24" - BOX BASE 8inW, 8inF, Variable Ht F/n - 41"
- 1) CASTING - HOE KY-206 F/C (KY TY1)
- 1) This Structure Includes a Cast-in Item
- 1) 24" x 24" - SGL 1"x14.5' Butyl
- 2) Hole - 18
- 1) Hole - 20

0 lb
 770 lb
 3997 lb
 206 lb
 0 lb
 0 lb
 0 lb
 0 lb

 Structure Total: 4973 lb

Structure Notes:
 1. KYTC JUNCTION BOX B1 / PER ASTM C913 SPEC'S.
 2. CONCRETE = 4,000 PSI AT 28 DAYS.
 3. TOP SLAB w KYTC TYPE 1 F/C CAST FLUSH (HOE KY-206 F/C).
 REINFORCING PER ASTM A615 (GRADE 60).
 - TOP SLAB (As .62) #5 BARS AT 6" C.C.E.W.
 - WALLS (As .31) #5 BARS AT 12" C.C.E.W.
 - FLOOR (As .31) #5 BARS AT 12: C.C.E.W.

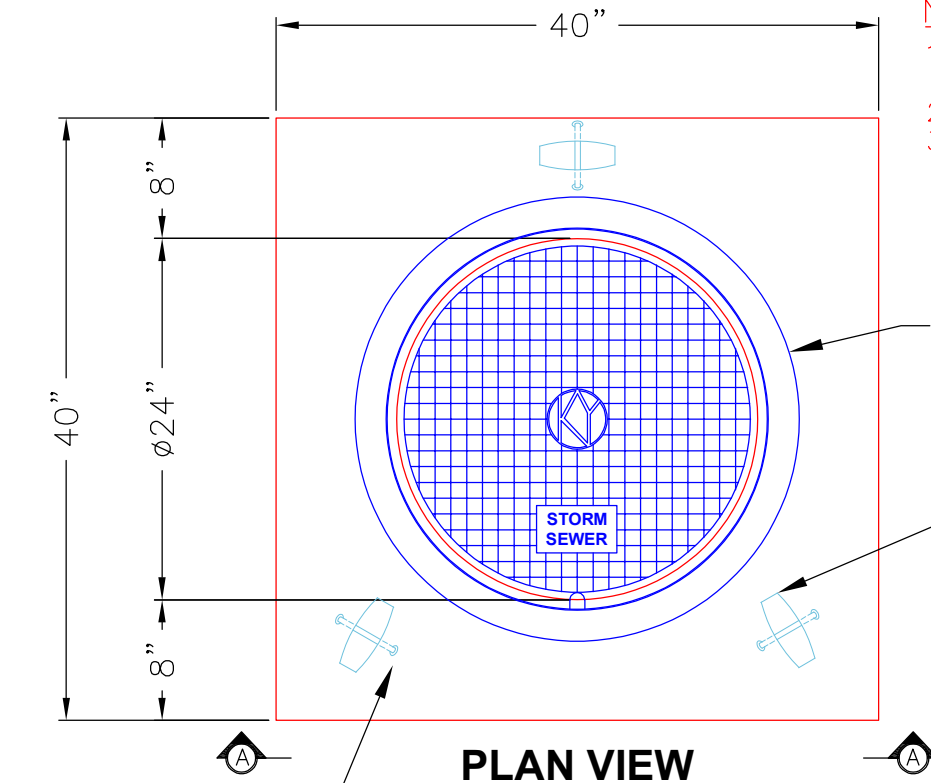

NOTES:

1. MANUFACTURED TO ASTM C-913 (LATEST REVISION).
2. CONCRETE: 4,000 PSI AT 28 DAYS.
3. REINFORCING: #5 BAR @ 6" C.C. E.W. (GRADE 60).

HOE KY-206 ϕ 24" FRAME
 CAST-IN AS SHOWN

3 EA. CONAC 5CA14
 A-ANCHORS FOR HANDLING.

BRUSHED FINISH

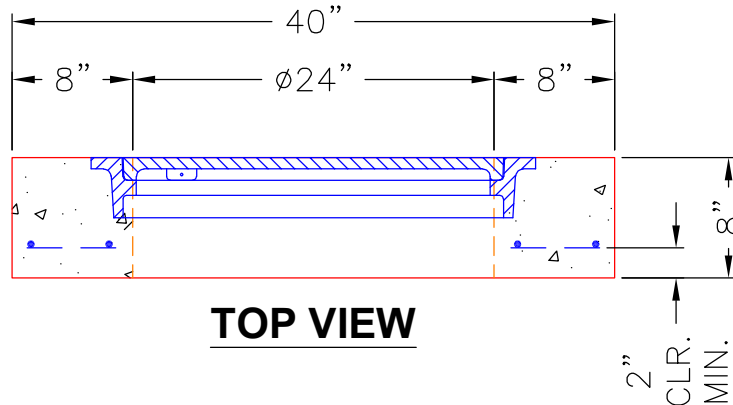

TOP VIEW

Coating (Int):
 Coating (Ext):

Seam Up: Flat
 Seam Dn: Flat

Wall Thickness: 8"

Height (Ext): 8"

Weight (Net): 770 lb
 Volume (Net): 0.2cu.yd