

Job Name: 25-3600 Signet FCU
 Job Location: Paducah, KY
 Contractor: Ainsworth Land Development, LLC

Plant: Beaver Dam
 5/8/2026 8:06:18 AM

Tech: S. Felletter
 PC: T. Lewis



Structure ID: DB1

P1 BX2424-08BAVF

BOX BASE 8inW, 8inF, Variable Ht F/n

- P2) 24" x 24" - CB FLAT TOP 8"W (HOE KY-215 F&G) F/F - 8"
- P1) 24" x 24" - BOX BASE 8inW, 8inF, Variable Ht F/n - 22"
- 1) This Structure Includes a Cast-in Item
- 1) CASTING - HOE KY-215 F/BEEHIVE (DBI 15)
- 1) 24" x 24" - Conseal CS-102 1.00"
- 1) Hole - 16
- 1) Hole - 8

770 lb
 2782 lb
 0 lb
 317 lb
 0 lb
 0 lb
 0 lb

 Structure Total: 3869 lb

- Structure Notes:**
1. KYTC DBI TYPE 15 / ASTM C913 SPECIFICATIONS
 2. CONCRETE = 4,000 PSI AT 28 DAYS.
 3. NO INVERT CHANNEL.
 4. DBI-15 F/G CAST INTO TOP SLAB (HOE KY-215 F/G BEEHIVE).

REINFORCING PER ASTM A615 (GRADE 60).
 - TOP SLAB (As .62) #5 BARS AT 6" C.C.E.W.
 - WALLS (As .31) #5 BARS AT 12" C.C.E.W.
 - FLOOR (As .31) #5 BARS AT 12" C.C.E.W.

Rim: 337.5' Rim to Invert: 2.5' Slack: 0" Sump: 0" Step Position:

Position	Elev	Angle	Ext. (cw)	Pipe	Pipe OD	Connector	Hole	Horz Size	Up (↓)	Offset
Invert 1	335'	65°	16.191"	12" HDPE	14.5"	Hole 16	16"	17.654"	-2"	5"
Invert 2	335'	270°	20"	4" PVC SCH40	4.5"	Hole 8	8"	8"	-2.001"	0"
Invert 3										
Invert 4										
Invert 5										
Invert 6										
Invert 7										
Invert 8										

RIGHT-SIDE UP VIEW (int. dimensions)

UPSIDE-DOWN VIEW (int. dimensions)

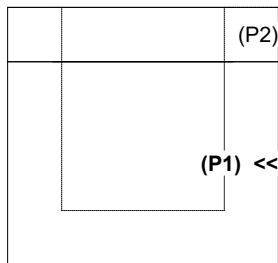
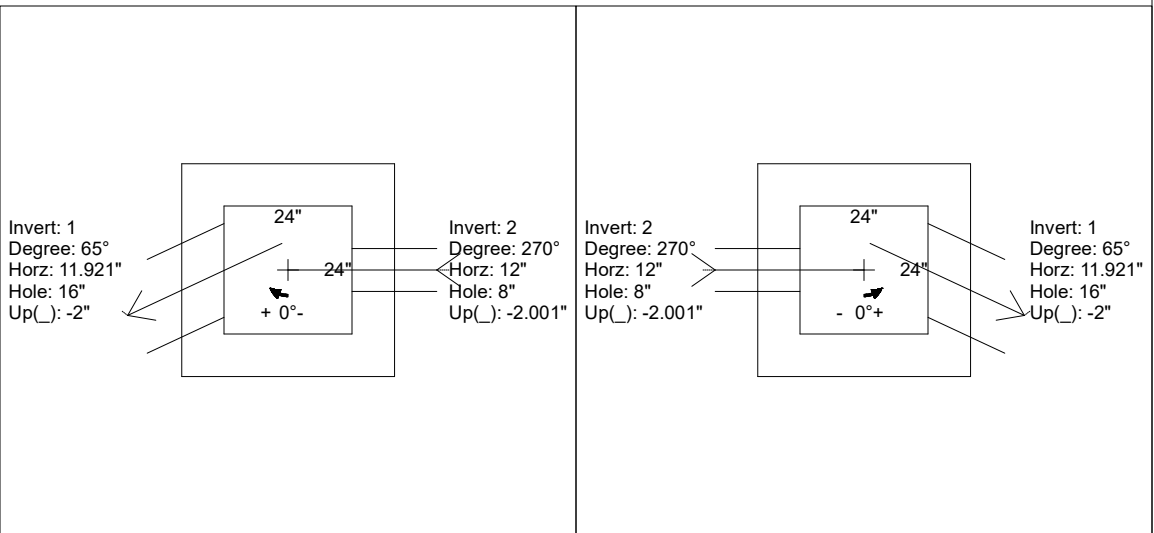

INSIDE WALL DIMENSIONS

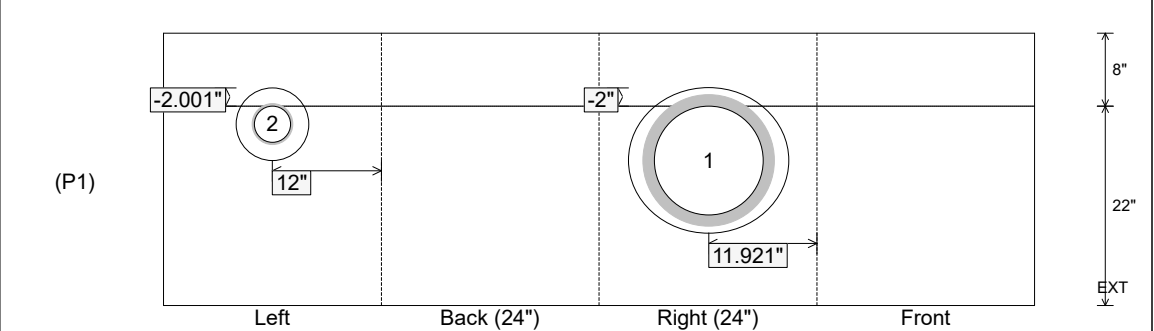

Coating (Int):
 Coating (Ext):

Seam Up: Flat
 Seam Dn: n/a

Wall Thickness: 8"
 Floor Height: 8"

Height (Int): 22"
 Height (Ext): 30"

Weight (Net): 2782 lb
 Volume (Net): 0.71cu.yd