

Job Name: 26-2074 - Christian Co. Ball Field Line K
 Job Location: Hopkinsville, KY
 Contractor: Herring Construction, Inc.

Plant: 100

Tech: J. Horsley

5/8/2026 6:13:58 AM

PC: E. Bradley



Structure ID: KST5 (JST1) ST-DBI

P2 BX024024-08LD08S

BX FLAT LID 8inW w/HOE 280T CAST IN F/F

- P3) 24" x 24" - CASTING (cast in) - 0"
- P2) 24" x 24" - BX FLAT LID 8inW w/HOE 280T CAST IN F/F - 8"
- P1) 24" x 24" - BOX BASE 8inW, 8inF, Variable Ht F/n - 29"
- 1) This Structure Includes a Cast-in Item - HOE 280T Frame (Supplied by iCast)
- 1) CASTING - HOE 280T F/G
- 2) 24" x 24" - Conseal CS-102 1.00"
- 1) Hole - 18

0 lb
 885 lb
 3395 lb
 0 lb
 182 lb
 0 lb
 0 lb

 4462 lb

Structure Total: 4462 lb

- Structure Notes:
1. PER ASTM C-913 SPECIFICATIONS
 2. CONCRETE: 4,000 PSI AT 28 DAYS
 3. REINFORCEMENT: #5 BAR @ 6" C.C. E.W. (GRADE 60) - 2" MIN. REBAR CLEARANCE (TYP)
 4. HOE 280T FRAME & GRATE SUPPLIED BY ICAST - FRAME TO BE CAST INTO FLAT LID FLANGE SIDE UP
 5. LIFTERS: 2 EA. CONAC A-W ANCHORS FOR PLANT & FIELD HANDLING - INSTALLED AS SHOWN
 6. TOP SURFACE TO RECEIVE LIGHT BRUSH FINISH

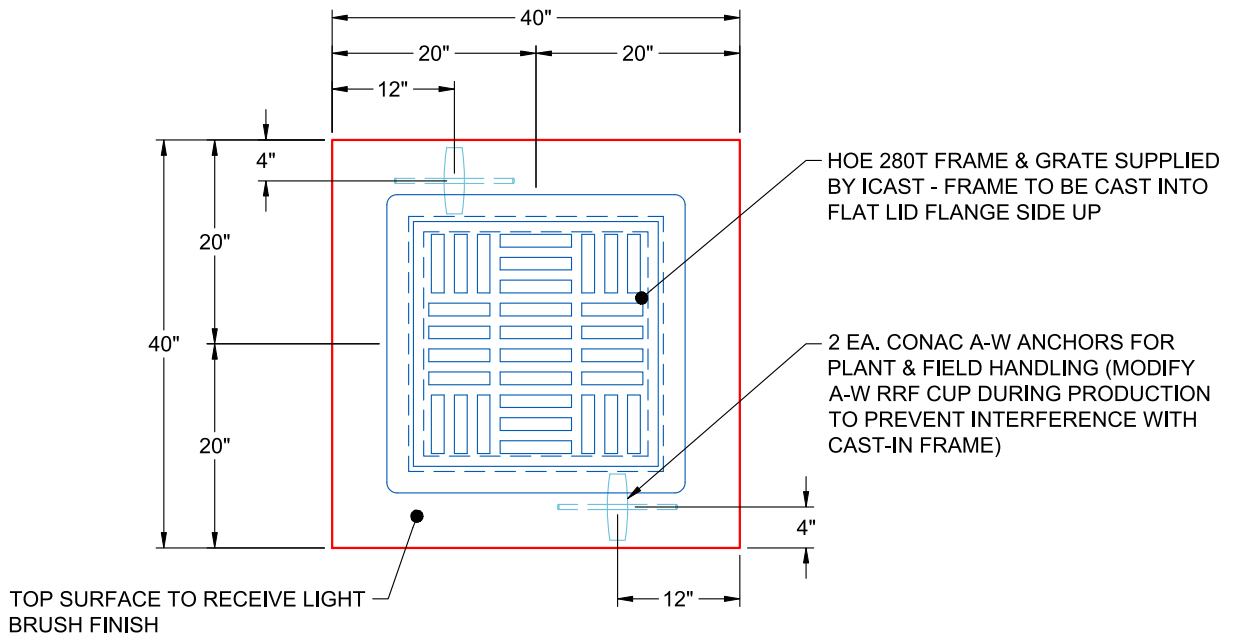

**PLAN VIEW
(RIGHT SIDE UP)**

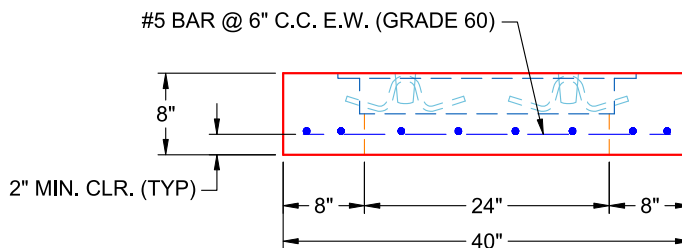

**FRONT VIEW
(RIGHT SIDE UP)**

Coating (Int):
 Coating (Ext):

Seam Up: Flat
 Seam Dn: Flat

Wall Thickness: 8"

Height (Ext): 8"

Weight (Net): 885 lb
 Volume (Net): 0.23cu.yd

Job Number:

26-2074

Job Name:

Christian Co. Ball Field Line K

Structure:

KST5 (JST1) ST-DBI

Note:

HOE 280T Frame Supplied By iCast
To Be Cast Into Flat Lid Flange Side
Up