

**Structure ID: 2 SS-MH**

**P2 MH048RS60**

**MH RISER T/G**

P5) 24" - CASTING HEIGHT - 7" P4) 24" - GRADE RING F/F - 4" P3) 48" - ECC CONE w/ 24" HOLE F/G - 42" P2) 48" - MH RISER T/G - 60" P1) 48" - MH BASE T/n - 24" 1) JOINT WRAP - 0.065"x6"x50' CONSEAL CS212 1) JOINT WRAP PRIMER - CONSEAL CS-75 (1 gal.) 1) 48" - MH INVERT CHANNEL - FULL HEIGHT 1) CASTING - HOE MC-420 F/C Sanitary 2) 48" - Conseal CS-102 1.00" (Double) 1) PSX - 12-08 NYLO 10) MH Step ML-10-TDS-NCR - 10"	0 lb 270 lb 3200 lb 4192 lb 2959 lb 0 lb 0 lb 1440 lb 340 lb 0 lb 8 lb 0 lb <hr style="width: 50px; margin-left: auto; margin-right: 0;"/> Structure Total: 12408 lb	<b>Structure Notes:</b> 1. PER ASTM C478 SPECIFICATIONS. 2. CONCRETE = 4,000 PSI AT 28 DAYS. 3. CASTING BY ICAST (HOE MC-420 F/C "SANITARY").  REINFORCING PER ASTM A615 (GRADE 60). - CONE (As .12) - RISER/WALLS (As .12) - FLOOR (As .31) #5 BARS AT 12 C.C.E.W.
-------------------------------------------------------------------------------------------------------------------------------------------------------------------------------------------------------------------------------------------------------------------------------------------------------------------------------------------------------------------------------------------------------------------------------------------------------------------	----------------------------------------------------------------------------------------------------------------------------------------------------------------------------------------------------------	---------------------------------------------------------------------------------------------------------------------------------------------------------------------------------------------------------------------------------------------------------------------------------------------

Rim: 745.3'    Rim to Invert: 11.37'    Slack: 1.44"    Sump: 2"    Step Position: 180°

Position	Elev	Angle	Ext. (cw)	Pipe	Pipe OD	Connector	Hole	Horz Size	Up (L)	Offset
Invert 1										
Invert 2										
Invert 3										
Invert 4										
Invert 5										
Invert 6										
Invert 7										
Invert 8										

**RIGHT-SIDE UP VIEW (int. dimensions)**

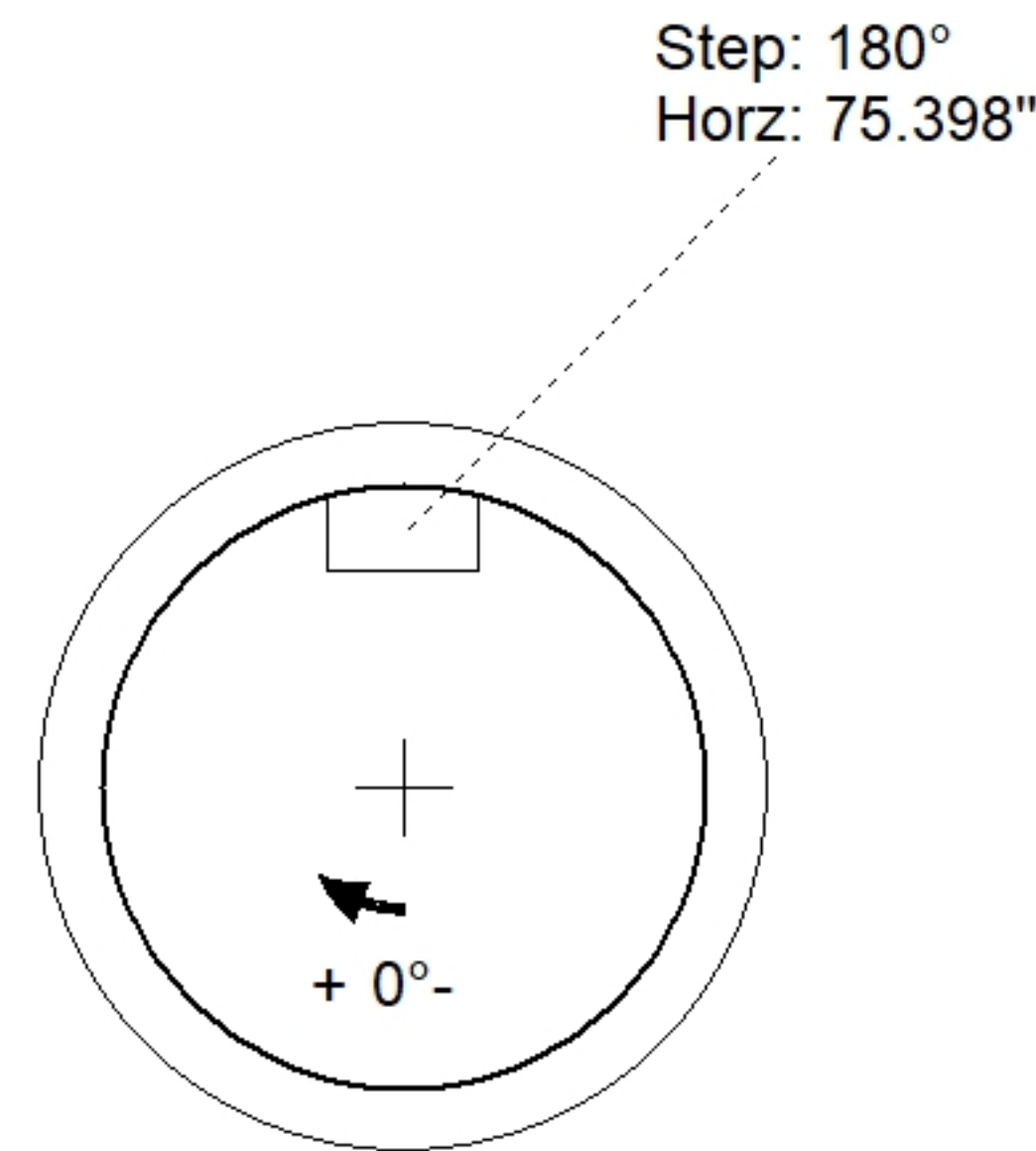
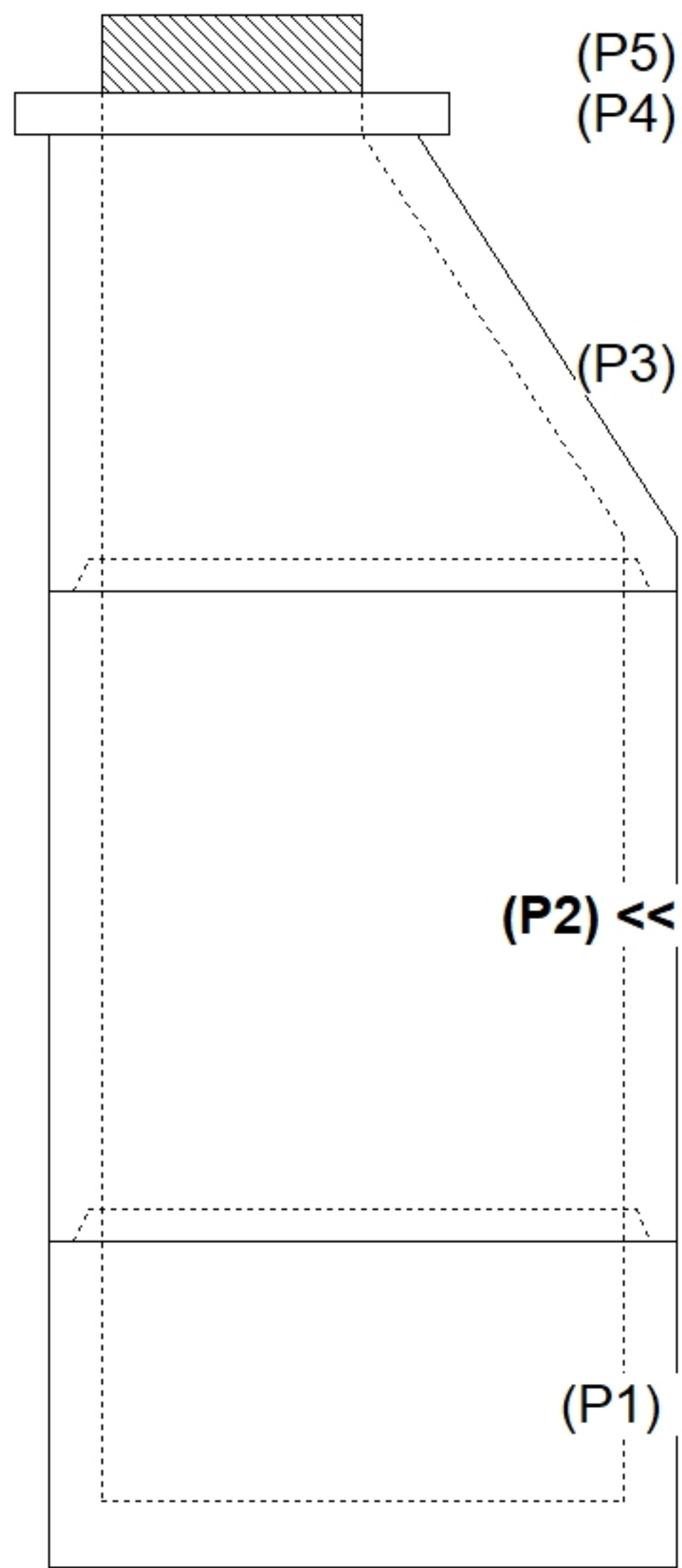

**INSIDE WALL DIMENSIONS**

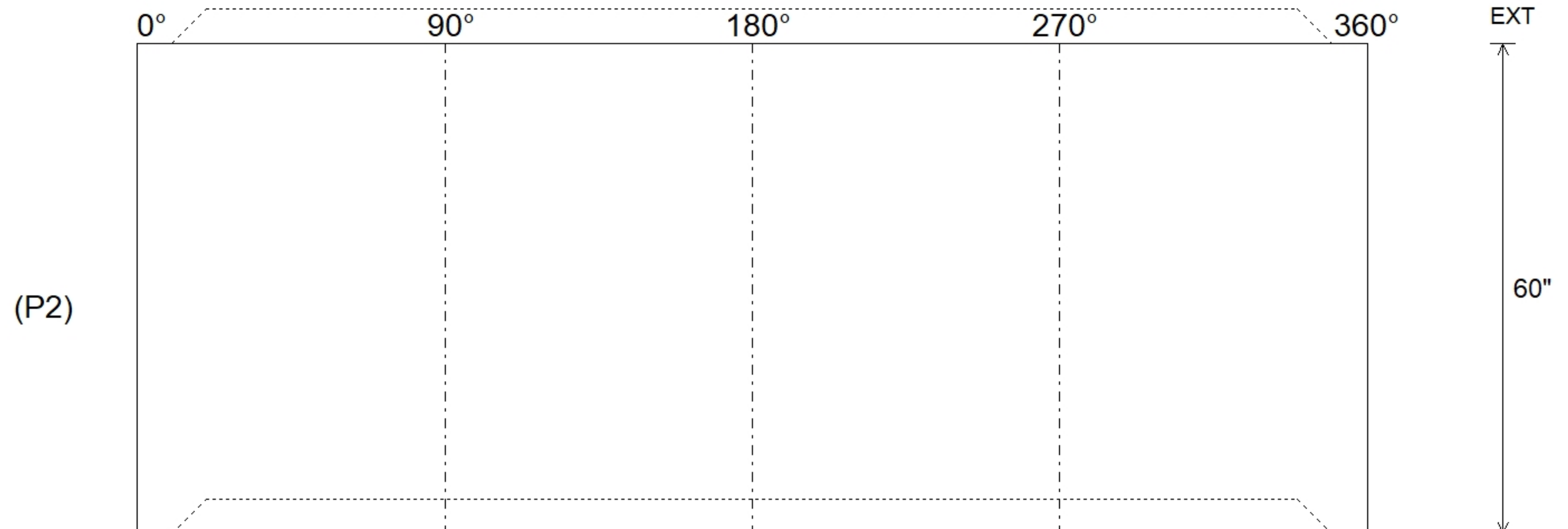

Coating (Int): Coating (Ext):	Seam Up: Tongue Seam Dn: Groove	Wall Thickness: 5" Floor Height: 0"	Height (Int): 60" Height (Ext): 60"	Weight (Net): 4192 lb Volume (Net): 1.07cu.yd
----------------------------------	------------------------------------	----------------------------------------	----------------------------------------	--------------------------------------------------