

**Structure ID: TY 1 DHMH WEST SIDE**

**P1 MH060DHRSVH**

**MH DH RISER Custom Ht T/F**

P4) 24" - CASTING HEIGHT - 7" P3) 60" - MH FLAT TOP w/ 24" ECC Hole F/G - 13" P2) 60" - MH RISER T/G - 60" P1) 60" - MH DH RISER Custom Ht T/F - 59" 1) JOINT WRAP - 0.065"x6"x50" CONSEAL CS212 1) JOINT WRAP PRIMER - CONSEAL CS-75 (1 gal.) 1) CASTING - HOE WT-420-MSD F/C Storm 2) 60" - Conseal CS-102 1.00" (Double) 2) DOGHOUSE - 34"x35" 1) PSX - 16Y NYLO 9) MH Step ML-10-TDS-NCR - 10"	0 lb 2869 lb 6264 lb 4927 lb 0 lb 0 lb 340 lb 0 lb 0 lb 8 lb 0 lb ----- Structure Total: 14408 lb
--	---

**Structure Notes:**

1. PER ASTM C-478 SPECIFICATIONS
2. CONCRETE: 4,000 PSI AT 28 DAYS
3. REINFORCEMENT: PER ASTM A615
4. STEPS AT 90 DEGREES
5. HOE WT-420-MSD WATERTIGHT FRAME & COVER "STORM MSD" SUPPLIED BY ICAST

Rim: 459.42'    Rim to Invert: 11.09'    Slack: 0.08"    Sump: 6"    Step Position: 90°

Position	Elev	Angle	Ext. (cw)	Pipe	Pipe OD	Connector	Hole	Horz Size	Up ( )	Offset
Invert 1	448.33'	0°	0"	24" RCP B WALL	30"	DOGHOUSE 34"x35"	34" x 35"	36.147"	0"	0"
Invert 2	448.33'	180°	113.125"	24" RCP B WALL	30"	DOGHOUSE 34"x35"	34" x 35"	36.147"	0"	0"
Invert 3	448.43'	270°	169.625"	10" PVC SDR35	10.5"	PSX 16Y NYLO	16"	16.196"	4.25"	0"
Invert 4										
Invert 5										
Invert 6										
Invert 7										
Invert 8										

RIGHT-SIDE UP VIEW (int. dimensions)

UPSIDE-DOWN VIEW (int. dimenions)

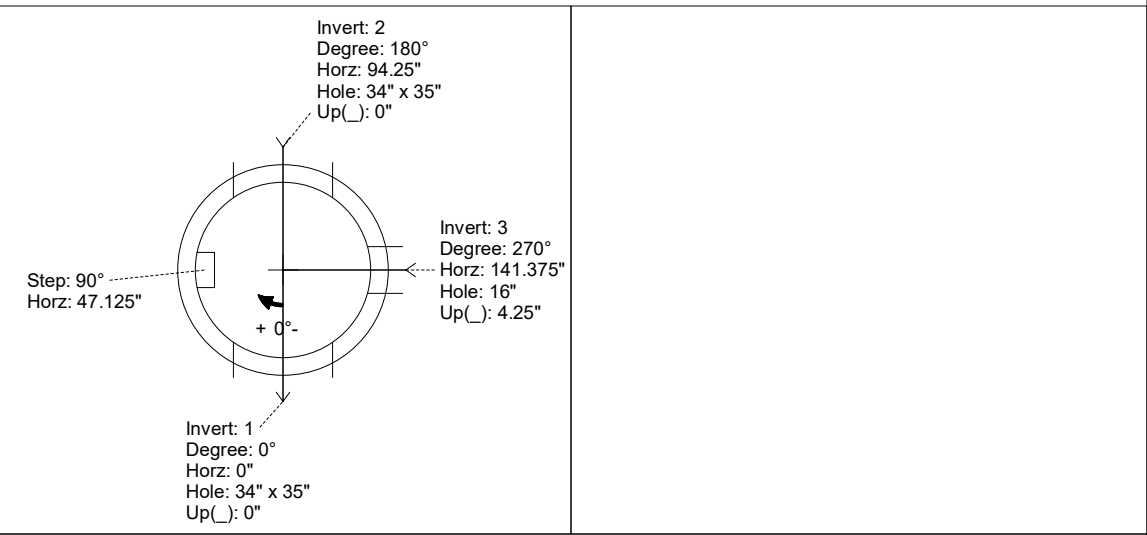

INSIDE WALL DIMENSIONS

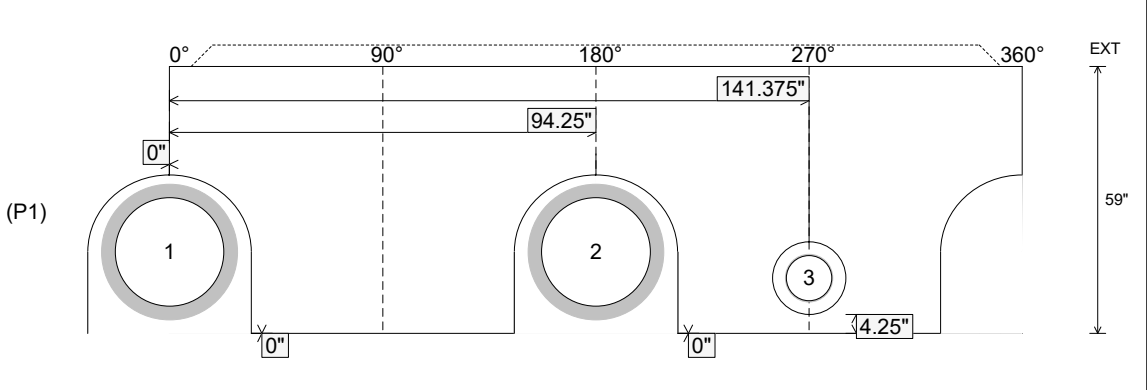

Coating (Int): Coating (Ext):	Seam Up: Tongue Seam Dn: Flat	Wall Thickness: 6" Floor Height: 0"	Height (Int): 59" Height (Ext): 59"	Weight (Net): 4927 lb Volume (Net): 1.26cu.yd
----------------------------------	----------------------------------	--	--	--