

Job Name: 26-1210 Sacramento Gravity Sewer  
 Job Location: Sacramento, KY  
 Contractor: Scott & Ritter, Inc.

Plant: Beaver Dam  
 4/23/2026 8:35:45 AM

Tech: S. Felletter  
 PC: T. Lewis



**Structure ID: C1MH2-27 SS-MH**

**P1 MH048BA30**

**MH BASE T/n**

- P3) 24" - CASTING HEIGHT - 7" 0 lb
  - P2) 48" - ECC CONE w/ 24" HOLE F/G - 36" 3000 lb
  - P1) 48" - MH BASE T/n - 30" 3330 lb
  - 1) JOINT WRAP - 0.065"x6"x50' CONSEAL CS212 0 lb
  - 1) JOINT WRAP PRIMER - CONSEAL CS-75 (1 gal.) 0 lb
  - 1) 48" - MH INVERT CHANNEL - FULL HEIGHT 1440 lb
  - 1) 48" - Conseal CS-102 1.00" (Double) 0 lb
  - 1) PSX - 12-08 DD (DBL Bands) 8 lb
  - 1) PSX - 12-06 DD (DBL Bands) 8 lb
  - 5) MH Step ML-10-TDS-NCR - 10" 0 lb
- Structure Total: 7786 lb

**Structure Notes:**  
 1. PER ASTM C478 SPECIFICATIONS.  
 2. CONCRETE = 4,000 PSI AT 28 DAYS.  
 3. CASTING BY OTHERS.

REINFORCING PER ASTM A615 (GRADE 60).  
 - CONE (As .12)  
 - RISER/WALLS (As .12)  
 - FLOOR (As .31) #5 BARS AT 12" C.C.E.W.

Rim: 498' Rim to Invert: 5.99' Slack: 0.88" Sump: 2" Step Position: 0°

Position	Elev	Angle	Ext. (cw)	Pipe	Pipe OD	Connector	Hole	Horz Size	Up ( )	Offset
Invert 1	492.01'	0°	0"	8" PVC SDR35	8.5"	PSX 12-08 DD (DBL Bands)	12"	12.129"	0"	0"
Invert 2	492.11'	270°	136.659"	6" PVC SDR35	6.25"	PSX 12-06 DD (DBL Bands)	12"	12.129"	0.2"	0"
Invert 3										
Invert 4										
Invert 5										
Invert 6										
Invert 7										
Invert 8										

RIGHT-SIDE UP VIEW (int. dimensions)

UPSIDE-DOWN VIEW (int. dimensions)

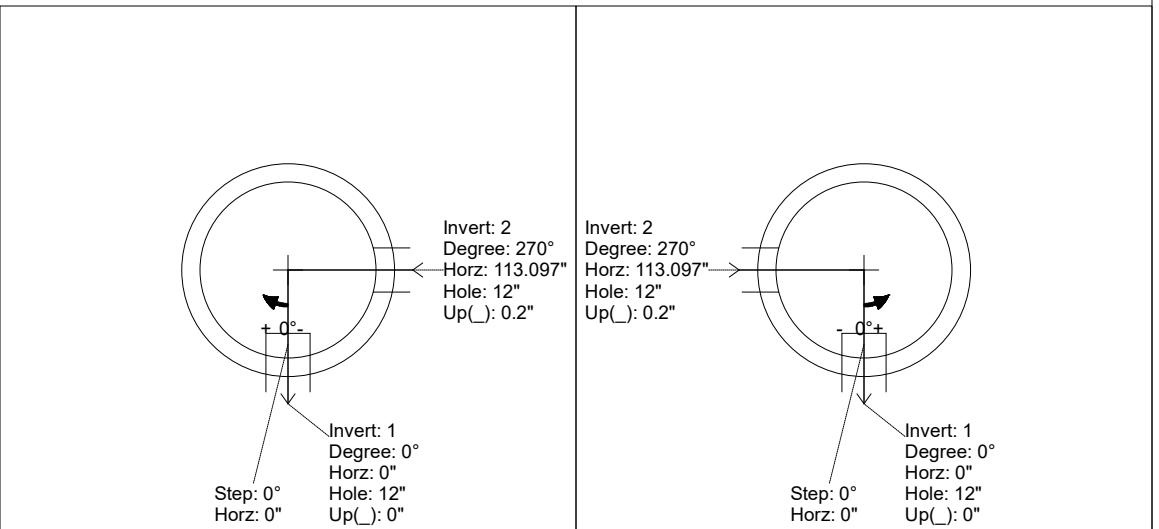
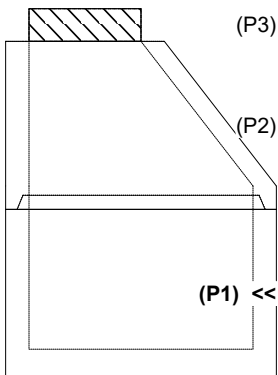

INSIDE WALL DIMENSIONS

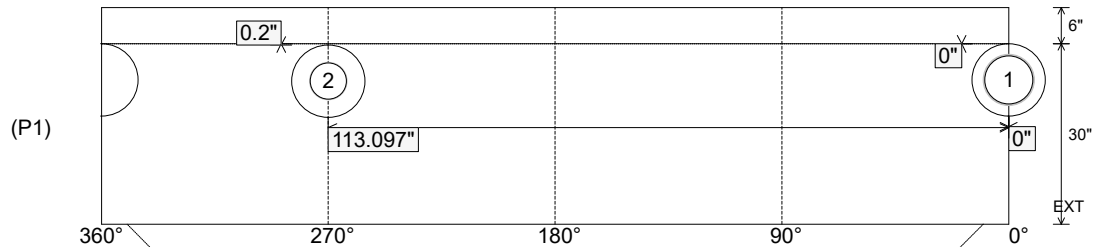

Coating (Int):  
 Coating (Ext):

Seam Up: Tongue  
 Seam Dn: n/a

Wall Thickness: 5"  
 Floor Height: 6"

Height (Int): 30"  
 Height (Ext): 36"

Weight (Net): 3330 lb  
 Volume (Net): 0.85cu.yd

Job Name: 26-1210 Sacramento Gravity Sewer  
 Job Location: Sacramento, KY  
 Contractor: Scott & Ritter, Inc.

Plant: Beaver Dam  
 4/23/2026 8:35:45 AM

Tech: S. Felletter  
 PC: T. Lewis



**Structure ID: C1MH2-27 SS-MH**

**P1 MH048BA30**

**MH BASE T/n**

- P3) 24" - CASTING HEIGHT - 7" 0 lb
  - P2) 48" - ECC CONE w/ 24" HOLE F/G - 36" 3000 lb
  - P1) 48" - MH BASE T/n - 30" 3330 lb
  - 1) JOINT WRAP - 0.065"x6"x50' CONSEAL CS212 0 lb
  - 1) JOINT WRAP PRIMER - CONSEAL CS-75 (1 gal.) 0 lb
  - 1) 48" - MH INVERT CHANNEL - FULL HEIGHT 1440 lb
  - 1) 48" - Conseal CS-102 1.00" (Double) 0 lb
  - 1) PSX - 12-08 DD (DBL Bands) 8 lb
  - 1) PSX - 12-06 DD (DBL Bands) 8 lb
  - 5) MH Step ML-10-TDS-NCR - 10" 0 lb
- Structure Total: 7786 lb

**Structure Notes:**  
 1. PER ASTM C478 SPECIFICATIONS.  
 2. CONCRETE = 4,000 PSI AT 28 DAYS.  
 3. CASTING BY OTHERS.

REINFORCING PER ASTM A615 (GRADE 60).  
 - CONE (As .12)  
 - RISER/WALLS (As .12)  
 - FLOOR (As .31) #5 BARS AT 12" C.C.E.W.

Invert channel drawing - full height invert

Rim: 498' Rim to Invert: 5.99' Slack: 0.88" Sump: 2" Step Position: 0°

Position	Elev	Angle	Ext. (cw)	Pipe	Pipe OD	Connector	Hole	Horz Size	Up ( )	Offset
Invert 1	492.01'	0°	0"	8" PVC SDR35	8.5"	PSX 12-08 DD (DBL Bands)	12"	12.129"	0"	0"
Invert 2	492.11'	270°	136.659"	6" PVC SDR35	6.25"	PSX 12-06 DD (DBL Bands)	12"	12.129"	0.2"	0"
Invert 3										
Invert 4										
Invert 5										
Invert 6										
Invert 7										
Invert 8										

RIGHT-SIDE UP VIEW (int. dimensions)

UPSIDE-DOWN VIEW (int. dimensions)

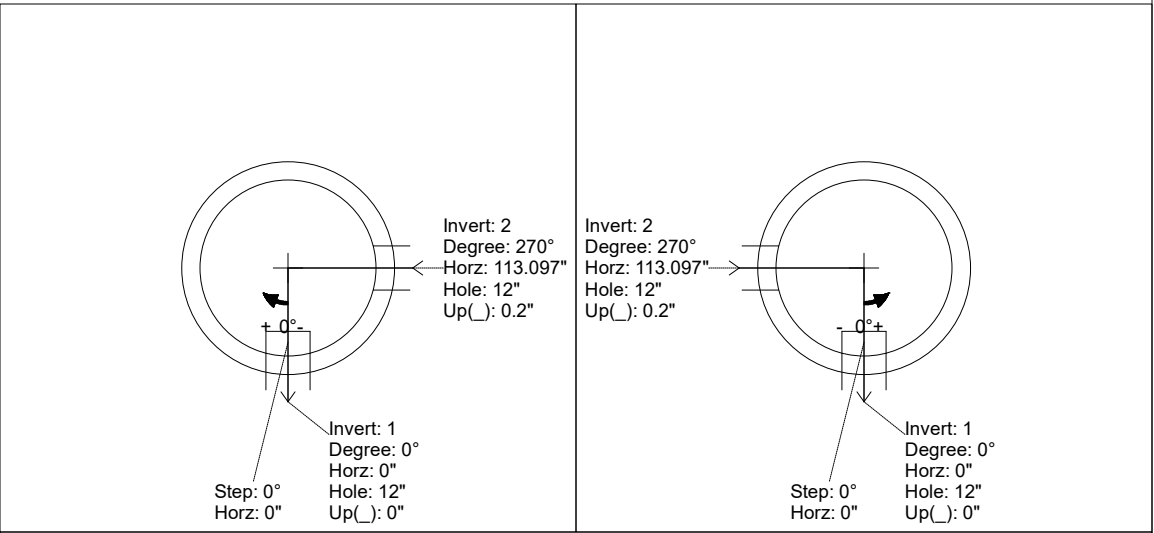
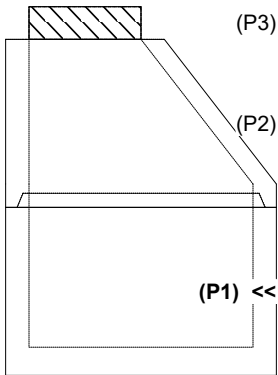

INSIDE WALL DIMENSIONS

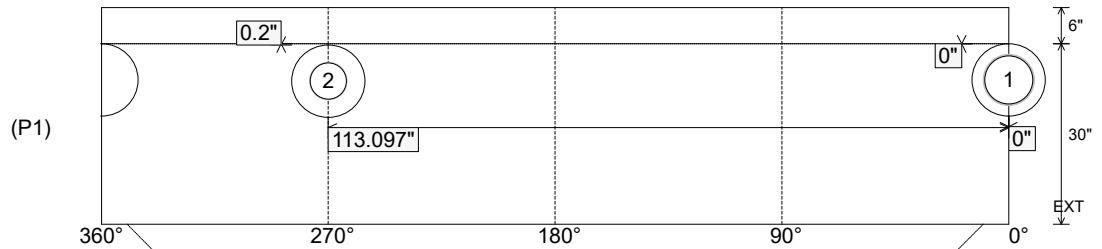

Coating (Int):  
 Coating (Ext):

Seam Up: Tongue  
 Seam Dn: n/a

Wall Thickness: 5"  
 Floor Height: 6"

Height (Int): 30"  
 Height (Ext): 36"

Weight (Net): 3330 lb  
 Volume (Net): 0.85cu.yd