

Job Name: 26-1077 - Westside Markets of Greensboro Village
 Job Location: Gallatin, TN
 Contractor: Cleary Construction, Inc.

Plant: 100
 5/5/2026 12:10:52 PM

Tech: J. Coppage - F
 PC: C. Goff



Structure ID: B3

P1 BX2436-08BA42

BOX BASE 8inW, 8inF T/n

- P3) 24" x 36" - CASTING HEIGHT - 5"
- P2) 24" x 36" - BOX RISER 8inW, Variable Ht F/G - 31"
- P1) 24" x 36" - BOX BASE 8inW, 8inF T/n - 42"
- 1) 24" x 36" - STORM INVERT CHANNEL (FLAT) - 4" THK
- 1) CASTING - EJ 6499 Beehive Grate
- 2) 24" x 36" - Conseal CS-102 1.00"
- 1) Hole - 38
- 1) Hole - 30
- 1) Hole - 6

0 lb
 3163 lb
 4617 lb
 450 lb
 250 lb
 0 lb
 0 lb
 0 lb
 0 lb
 0 lb
 Structure Total: 8480 lb

Structure Notes:
 1. PER ASTM C913 SPECIFICATIONS.
 2. CONCRETE = 4,000 PSI AT 28 DAYS.
 3. NO STEPS.
 4. CASTING SUPPLIED BY I-CAST (EJ 6499).

 REINFORCING PER ASTM A615 (GRADE 60).
 - WALLS (As .12) #5 BARS AT 12" C.C.E.W.
 - FLOOR (As .12) #5 BARS AT 12" C.C.E.W.

Rim: 497' Rim to Invert: 6.52' Slack: 0.24" Sump: 0" Step Position:

Position	Elev	Angle	Ext. (cw)	Pipe	Pipe OD	Connector	Hole	Horz Size	Up ()	Offset
Invert 1	490.48'	270°	26"	30" HDPE	35.1"	Hole 38	38"	37"	-2.5"	0"
Invert 2	490.6'	90°	26"	24" HDPE	27.8"	Hole 30	30"	30"	-0.5"	0"
Invert 3	492.64'	180°	20"	4" HDPE (perf pipe)	4.8"	Hole 6	6"	6"	25.5"	0"
Invert 4										
Invert 5										
Invert 6										
Invert 7										
Invert 8										

RIGHT-SIDE UP VIEW (int. dimensions)

UPSIDE-DOWN VIEW (int. dimensions)

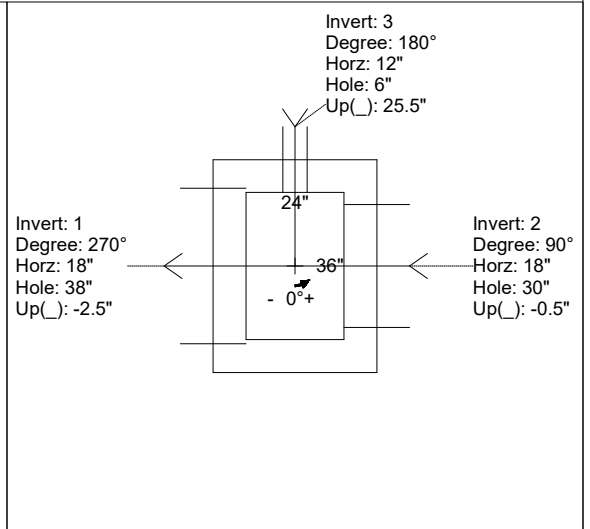
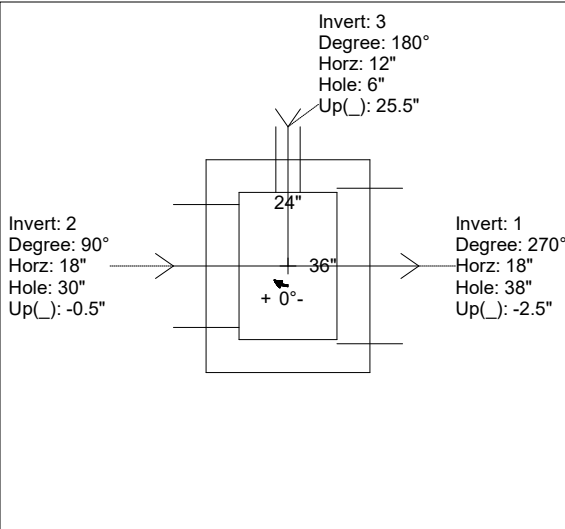
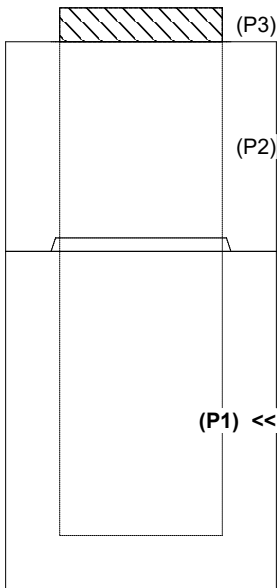

INSIDE WALL DIMENSIONS

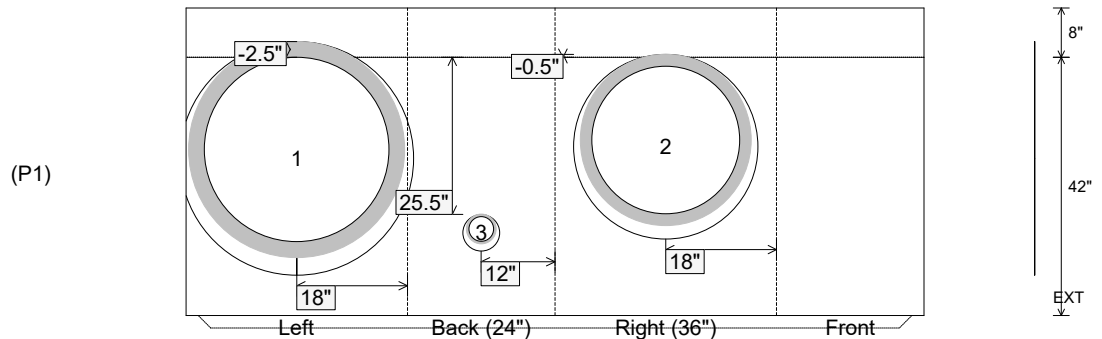

Coating (Int):
 Coating (Ext):

Seam Up: Tongue
 Seam Dn: n/a

Wall Thickness: 8"
 Floor Height: 8"

Height (Int): 42"
 Height (Ext): 50"

Weight (Net): 4617 lb
 Volume (Net): 1.18cu.yd

Job Name: 26-1077 - Westside Markets of Greensboro Village
 Job Location: Gallatin, TN
 Contractor: Cleary Construction, Inc.

Plant: 100
 5/5/2026 12:10:52 PM

Tech: J. Coppage - F
 PC: C. Goff



Structure ID: B3

P1 BX2436-08BA42

BOX BASE 8inW, 8inF T/n

- P3) 24" x 36" - CASTING HEIGHT - 5"
- P2) 24" x 36" - BOX RISER 8inW, Variable Ht F/G - 31"
- P1) 24" x 36" - BOX BASE 8inW, 8inF T/n - 42"

1) 24" x 36" - STORM INVERT CHANNEL (FLAT) - 4" THK

- 1) CASTING - EJ 6499 Beehive Grate
- 2) 24" x 36" - Conseal CS-102 1.00"
- 1) Hole - 38
- 1) Hole - 30
- 1) Hole - 6

0 lb
 3163 lb
 4617 lb
 450 lb
 250 lb
 0 lb
 0 lb
 0 lb
 0 lb
 0 lb
 Structure Total: 8480 lb

Structure Notes:

1. PER ASTM C913 SPECIFICATIONS.
2. CONCRETE = 4,000 PSI AT 28 DAYS.
3. NO STEPS.
4. CASTING SUPPLIED BY I-CAST (EJ 6499).

REINFORCING PER ASTM A615 (GRADE 60).
 - WALLS (As .12) #5 BARS AT 12" C.C.E.W.
 - FLOOR (As .12) #5 BARS AT 12" C.C.E.W.

Rim: 497' Rim to Invert: 6.52' Slack: 0.24" Sump: 0" Step Position:

Position	Elev	Angle	Ext. (cw)	Pipe	Pipe OD	Connector	Hole	Horz Size	Up ()	Offset
Invert 1	490.48'	270°	26"	30" HDPE	35.1"	Hole 38	38"	37"	-2.5"	0"
Invert 2	490.6'	90°	26"	24" HDPE	27.8"	Hole 30	30"	30"	-0.5"	0"
Invert 3	492.64'	180°	20"	4" HDPE (perf pipe)	4.8"	Hole 6	6"	6"	25.5"	0"
Invert 4										
Invert 5										
Invert 6										
Invert 7										
Invert 8										

RIGHT-SIDE UP VIEW (int. dimensions)

UPSIDE-DOWN VIEW (int. dimensions)

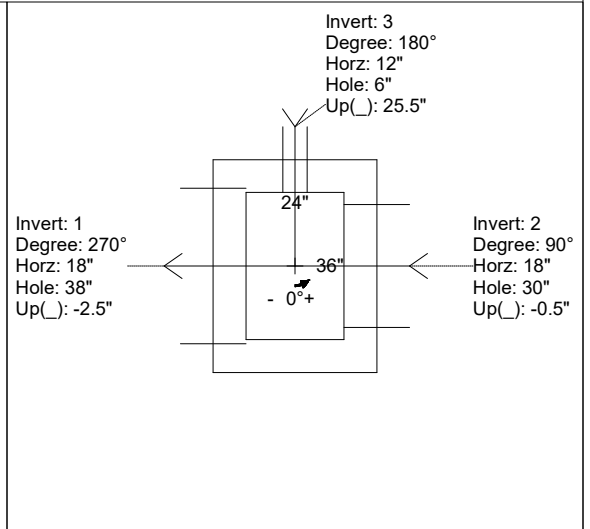
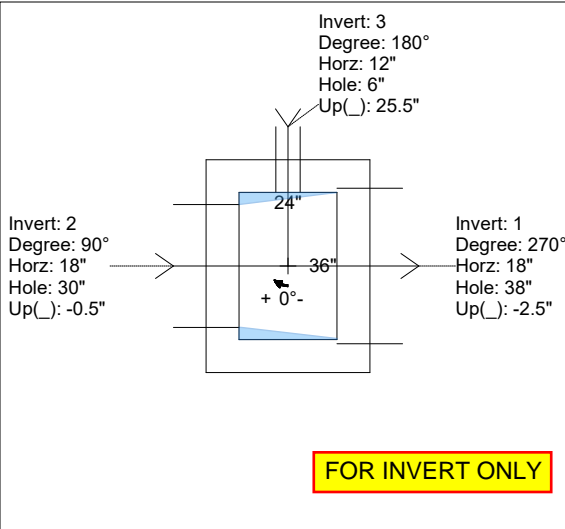
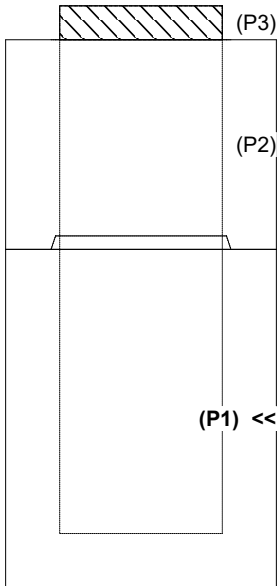

INSIDE WALL DIMENSIONS

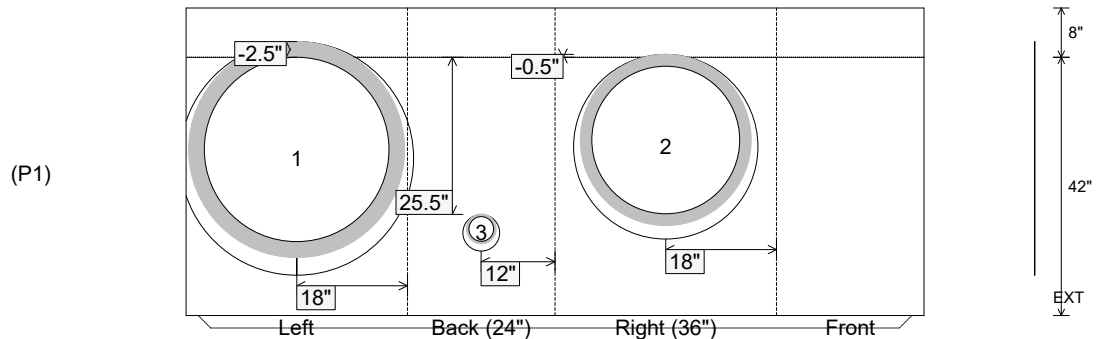

Coating (Int):
 Coating (Ext):

Seam Up: Tongue
 Seam Dn: n/a

Wall Thickness: 8"
 Floor Height: 8"

Height (Int): 42"
 Height (Ext): 50"

Weight (Net): 4617 lb
 Volume (Net): 1.18cu.yd