

Job Name: 25-4508 - Georgetown Commons Target
 Job Location: Georgetown, KY
 Contractor: Winwater Hartford KY Co.

Plant: 100
 5/28/2026 11:25:31 AM

Tech: Jared - F
 PC: A. Chambers



Structure ID: 8 (11)

P1 MH060BAVF

MH BASE Custom Ht T/n

- P3) 24" x 36" - CASTING HEIGHT - 6"
- P2) 60" - MH FLAT TOP w/24"x36" Hole F/G - 13"
- P1) 60" - MH BASE Custom Ht T/n - 47"
- 1) CASTING - HOE 470 SET LV (F/G/H)
- 1) 60" - Conseal CS-102 1.00"
- 1) 24" x 36" - Conseal CS-102 1.00"
- 1) Hole - 38
- 1) Hole - 30

0 lb
 3499 lb
 6660 lb
 394 lb
 0 lb
 0 lb
 0 lb
 0 lb
 0 lb
 Structure Total: 10553 lb

Structure Notes:
 1. PER ASTM C478 SPECIFICATIONS.
 2. CONCRETE = 4,000 PSI AT 28 DAYS.
 3. NO STEPS AND NO INVERT CHANNEL.
 4. CASTING BY ICAST (HOE 470 SET LV (F/G/H)).

REINFORCING PER ASTM A615 (GRADE 60).
 - TOP SLAB (As .62) #5 BARS AT 6" C.C.E.W..
 - RISER/WALLS (As .18)
 - FLOOR (As .37) #5 BARS AT 10" C.C.E.W.

Rim: 870.9' Rim to Invert: 5.3' Slack: 0.15" Sump: 2.55" Step Position:

Position	Elev	Angle	Ext. (cw)	Pipe	Pipe OD	Connector	Hole	Horz Size	Up (↓)	Offset
Invert 1	865.6'	0°	0"	30" HDPE	35.1"	Hole 38	38"	41.151"	0"	0"
Invert 2	865.6'	172°	108.125"	24" HDPE	27.8"	Hole 30	30"	31.416"	0.625"	0"
Invert 3										
Invert 4										
Invert 5										
Invert 6										
Invert 7										
Invert 8										

RIGHT-SIDE UP VIEW (int. dimensions)

UPSIDE-DOWN VIEW (int. dimensions)

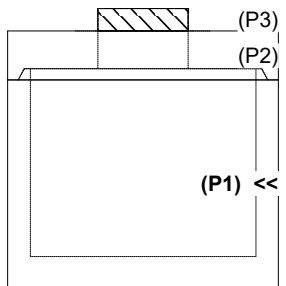
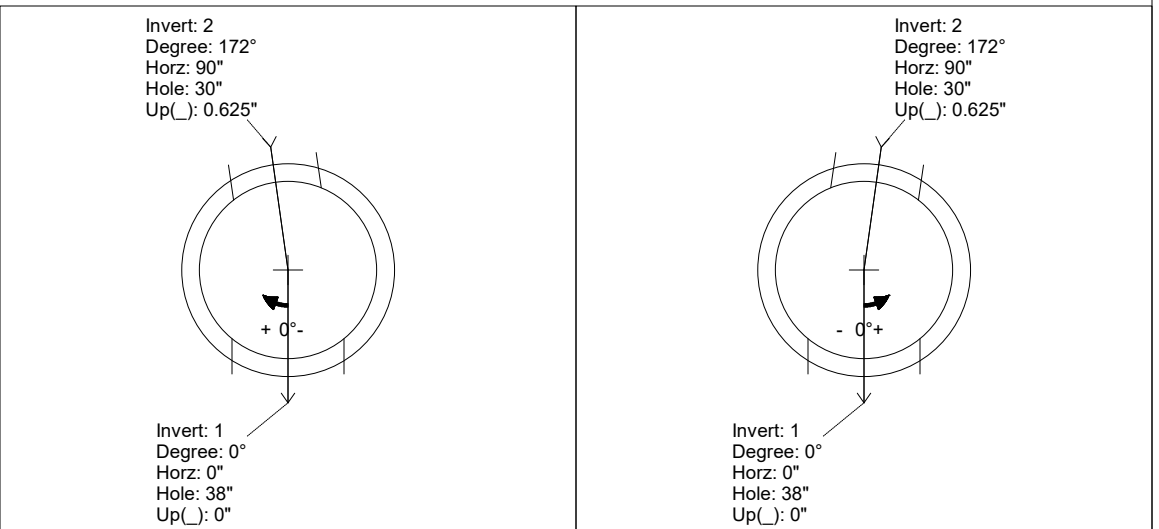

INSIDE WALL DIMENSIONS

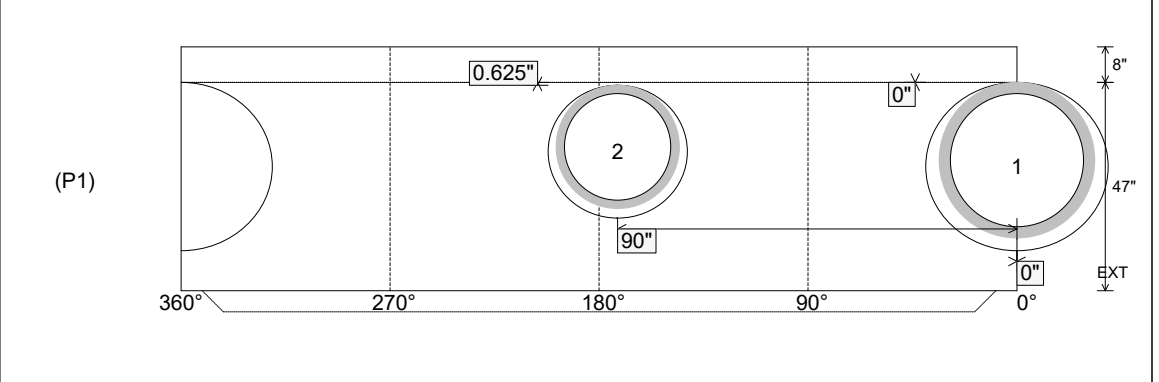

Coating (Int): Coating (Ext):	Seam Up: Tongue Seam Dn: n/a	Wall Thickness: 6" Floor Height: 8"	Height (Int): 47" Height (Ext): 55"	Weight (Net): 6660 lb Volume (Net): 1.7cu.yd
----------------------------------	---------------------------------	----------------------------------------	----------------------------------------	-------------------------------------------------