

GENERAL NOTES:

1. MANUFACTURED TO ASTM C-913 (LATEST REVISION).
2. CONCRETE: 4,500 PSI AT 28 DAYS. CONCRETE.
3. REINFORCING: TOP SLAB #5 BAR @ 8" E.W. O.C. (GRADE 60).
4. WEIGHT: TOP SLAB = 8,195 LBS
5. JOINT SEALANT TO BE CONSEAL CS-102, 1".

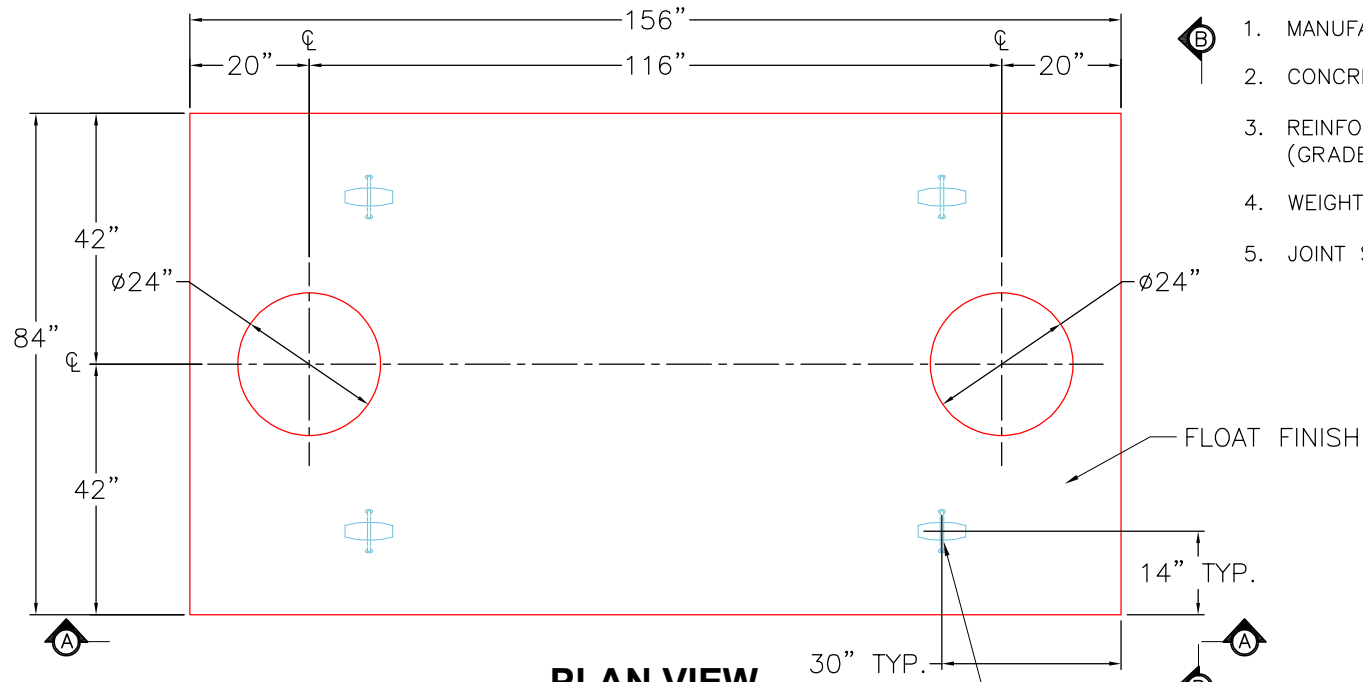

PLAN VIEW

4 EA. CONAC 4CA14 ANCHORS
CAST IN SECTION AS SHOWN
FOR PLANT & FIELD HANDLING.

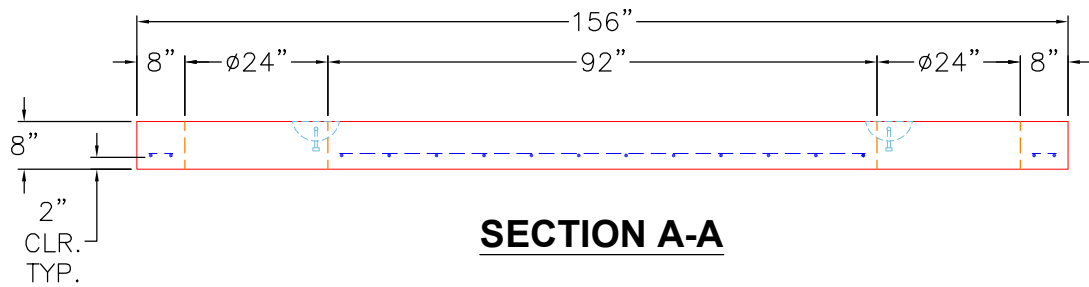

SECTION A-A

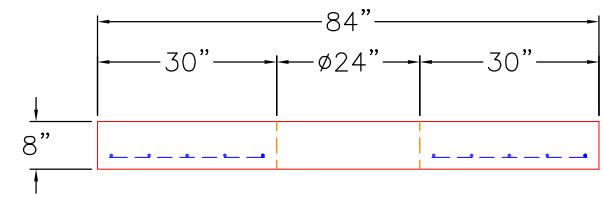

SECTION B-B

<p>PRODUCTION WORK ORDER</p>		<p>PRODUCT I.D.: BX072144-08LD06S</p>	<p>DESCRIPTION: 84" X 156" X 8" THICK TOP SLAB</p>	
	<p>QUALITY CONTROL CHECKLIST</p> <p><input type="checkbox"/> ALL DIMENSIONS CORRECT.</p> <p><input type="checkbox"/> LIFTERS INSTALLED.</p> <p><input type="checkbox"/> OPENING CORRECT.</p> <p><input type="checkbox"/> REINFORCING CORRECT.</p> <p><input type="checkbox"/> SURFACE QUALITY ACCEPTABLE.</p> <p><input type="checkbox"/> EDGES CHAMFERED.</p> <p><input type="checkbox"/> ALL PATCHWORK ACCEPTABLE.</p>		<p>CUSTOMER: CORE & MAIN LP</p>	
	<p>PLANT: BEAVER DAM, KY.</p>		<p>PROJECT: METRO CENTER GREASE TRAP</p>	
	<p>WEIGHT: 8,195 LBS.</p>		<p>STRUCTURE: QL1 GT2000 (2)</p>	
	<p>TOP SECTION JOINT: N/A</p>		<p>ORDER NO: 26-2243</p>	
	<p>BASE SECTION JOINT: N/A</p>		<p>PC: T. RYAN</p>	<p>DRAWING: S. FELLETER</p>
<p>QC CHECK INITIALS:</p>		<p>DATE: 05/07/26</p>	<p>SCALE: NTS</p>	<p>PG. 1 of 1</p>