

Job Name: 26-1228 - L&N Federal Credit Union  
 Job Location: Louisville, KY 40243  
 Contractor: H & W Landworks

Plant: 100

Tech: Jared - A

5/6/2026 12:05:20 PM

PC: T. Lewis



**Structure ID: S-6-7 CB1**

**P1 MH048BA36**

**MH BASE T/n**

- P3) 34" x 34" - CASTING HEIGHT - 3"
- P2) 48" - MH FLAT TOP w/34"x34" Hole F/G - 12"
- P1) 48" - MH BASE T/n - 36"
- 1) CASTING - HOE 595 F/G
- 1) 48" - Conseal CS-102 1.00"
- 2) Hole - 18
- 3) MH Step ML-10-TDS-NCR - 10"

0 lb  
 1194 lb  
 3627 lb  
 376 lb  
 0 lb  
 0 lb  
 0 lb  
 -----  
 Structure Total: 5197 lb

- Structure Notes:**
1. PER LOUISVILLE MSD / ASTM C-478 SPECS
  2. CONCRETE: 4,000 PSI AT 28 DAYS
  3. REINFORCEMENT: PER ASTM A615
  4. NO STORM INVERT
  5. STEPS AT 229 DEGREES
  6. HOE 595 FRAME & GRATES SUPPLIED BY ICAST

Rim: 747.25' Rim to Invert: 4.45' Slack: 2.4' Sump: 0' Step Position: 229

Position	Elev	Angle	Ext. (cw)	Pipe	Pipe OD	Connector	Hole	Horz Size	Up ( )	Offset
Invert 1	742.8'	0°	0"	12" ADS N-12	14.5"	Hole 18	18"	18.451"	-1.25"	0"
Invert 2	742.8'	139°	70.375"	12" ADS N-12	14.5"	Hole 18	18"	18.451"	-1.25"	0"
Invert 3										
Invert 4										
Invert 5										
Invert 6										
Invert 7										
Invert 8										

RIGHT-SIDE UP VIEW (int. dimensions)

UPSIDE-DOWN VIEW (int. dimenions)

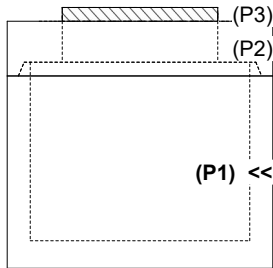
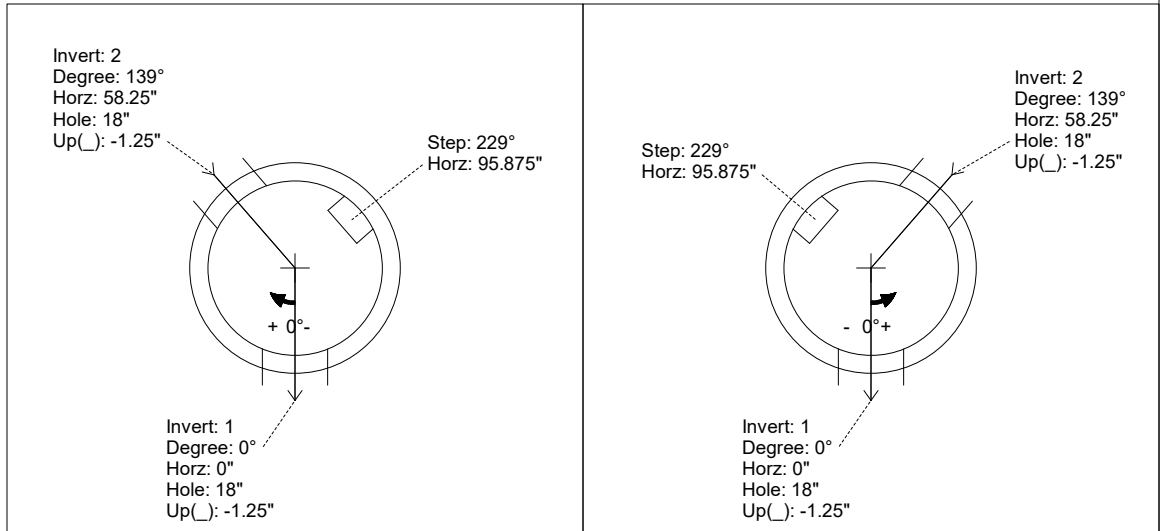

INSIDE WALL DIMENSIONS

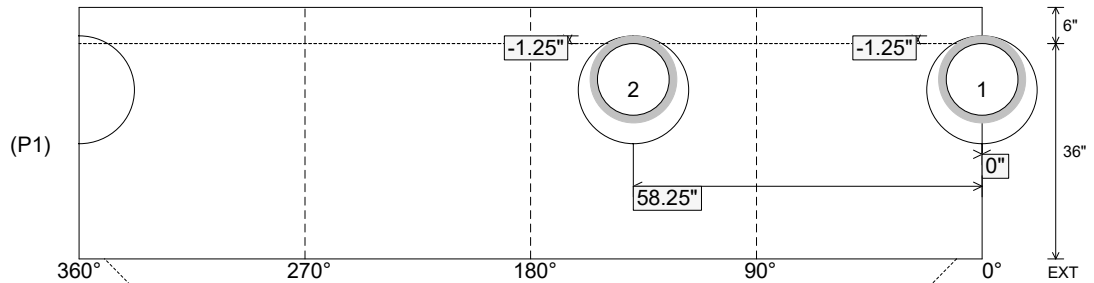

Coating (Int):  
 Coating (Ext):

Seam Up: Tongue  
 Seam Dn: n/a

Wall Thickness: 5"  
 Floor Height: 6"

Height (Int): 36"  
 Height (Ext): 42"

Weight (Net): 3627 lb  
 Volume (Net): 0.93cu.yd