

Job Name: 26-1210 Sacramento Gravity Sewer  
 Job Location: Sacramento, KY  
 Contractor: Scott & Ritter, Inc.

Plant: Beaver Dam  
 4/23/2026 8:35:47 AM

Tech: S. Felletter  
 PC: T. Lewis



**Structure ID: DMH4-31 SS-MH**

**P1 MH048BA18**

**MH BASE T/n**

P4) 24" - CASTING HEIGHT - 7"	0 lb
P3) 48" - ECC CONE w/ 24" HOLE F/G - 24"	1550 lb
P2) 48" - MH RISER T/G - 48"	3353 lb
P1) 48" - MH BASE T/n - 18"	2492 lb
1) JOINT WRAP - 0.065"x6"x50' CONSEAL CS212	0 lb
1) JOINT WRAP PRIMER - CONSEAL CS-75 (1 gal.)	0 lb
1) 48" - MH INVERT CHANNEL - FULL HEIGHT	1440 lb
2) 48" - Conseal CS-102 1.00" (Double)	0 lb
2) PSX - 12-08 DD (DBL Bands)	16 lb
7) MH Step ML-10-TDS-NCR - 10"	0 lb
Structure Total:	8851 lb

**Structure Notes:**  
 1. PER ASTM C478 SPECIFICATIONS.  
 2. CONCRETE = 4,000 PSI AT 28 DAYS.  
 3. CASTING BY OTHERS.

REINFORCING PER ASTM A615 (GRADE 60).  
 - CONE (As .12)  
 - RISER/WALLS (As .12)  
 - FLOOR (As .31) #5 BARS AT 12" C.C.E.W.

Rim: 480.58' Rim to Invert: 8.13' Slack: 2.56" Sump: 2" Step Position: 0°

Position	Elev	Angle	Ext. (cw)	Pipe	Pipe OD	Connector	Hole	Horz Size	Up ( )	Offset
Invert 1	472.45'	0°	0"	8" PVC SDR35	8.5"	PSX 12-08 DD (DBL Bands)	12"	12.129"	0"	0"
Invert 2	472.55'	217°	109.834"	8" PVC SDR35	8.5"	PSX 12-08 DD (DBL Bands)	12"	12.129"	1.2"	0"
Invert 3										
Invert 4										
Invert 5										
Invert 6										
Invert 7										
Invert 8										

RIGHT-SIDE UP VIEW (int. dimensions)

UPSIDE-DOWN VIEW (int. dimensions)

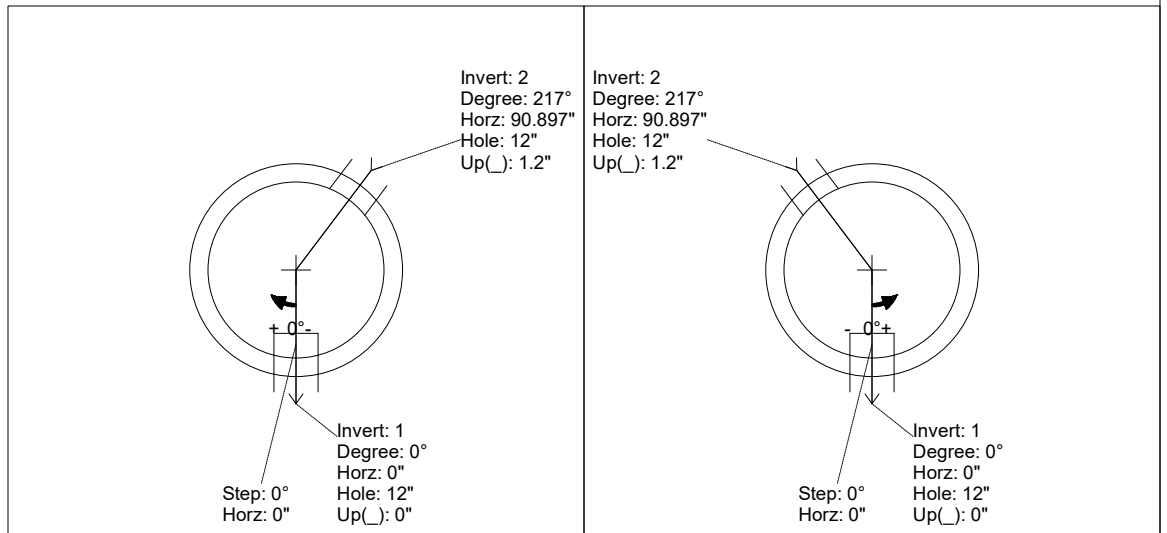
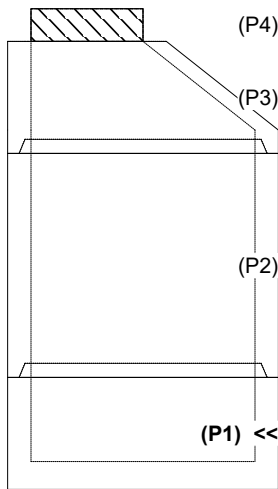

INSIDE WALL DIMENSIONS

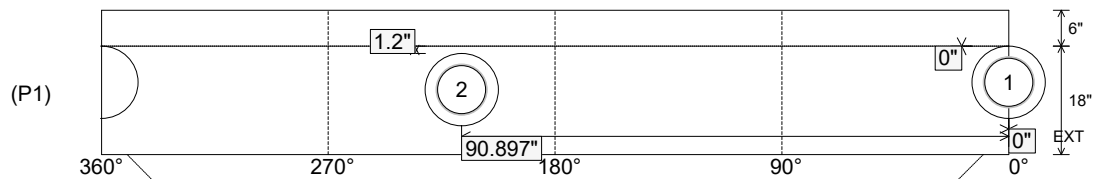

Coating (Int): Coating (Ext):	Seam Up: Tongue Seam Dn: n/a	Wall Thickness: 5" Floor Height: 6"	Height (Int): 18" Height (Ext): 24"	Weight (Net): 2492 lb Volume (Net): 0.64cu.yd
----------------------------------	---------------------------------	--	--	--

Job Name: 26-1210 Sacramento Gravity Sewer  
 Job Location: Sacramento, KY  
 Contractor: Scott & Ritter, Inc.

Plant: Beaver Dam  
 4/23/2026 8:35:47 AM

Tech: S. Felletter  
 PC: T. Lewis



**Structure ID: DMH4-31 SS-MH**

**P1 MH048BA18**

**MH BASE T/n**

- P4) 24" - CASTING HEIGHT - 7"
- P3) 48" - ECC CONE w/ 24" HOLE F/G - 24"
- P2) 48" - MH RISER T/G - 48"
- P1) 48" - MH BASE T/n - 18"
- 1) JOINT WRAP - 0.065"x6"x50' CONSEAL CS212
- 1) JOINT WRAP PRIMER - CONSEAL CS-75 (1 gal.)
- 1) 48" - MH INVERT CHANNEL - FULL HEIGHT
- 2) 48" - Conseal CS-102 1.00" (Double)
- 2) PSX - 12-08 DD (DBL Bands)
- 7) MH Step ML-10-TDS-NCR - 10"

0 lb  
 1550 lb  
 3353 lb  
 2492 lb  
 0 lb  
 0 lb  
 1440 lb  
 0 lb  
 16 lb  
 0 lb  
 -----  
 Structure Total: 8851 lb

**Structure Notes:**  
 1. PER ASTM C478 SPECIFICATIONS.  
 2. CONCRETE = 4,000 PSI AT 28 DAYS.  
 3. CASTING BY OTHERS.  
  
 REINFORCING PER ASTM A615 (GRADE 60).  
 - CONE (As .12)  
 - RISER/WALLS (As .12)  
 - FLOOR (As .31) #5 BARS AT 12" C.C.E.W.

**Invert channel drawing - full height invert**

Rim: 480.58' Rim to Invert: 8.13' Slack: 2.56" Sump: 2" Step Position: 0°

Position	Elev	Angle	Ext. (cw)	Pipe	Pipe OD	Connector	Hole	Horz Size	Up ( )	Offset
Invert 1	472.45'	0°	0"	8" PVC SDR35	8.5"	PSX 12-08 DD (DBL Bands)	12"	12.129"	0"	0"
Invert 2	472.55'	217°	109.834"	8" PVC SDR35	8.5"	PSX 12-08 DD (DBL Bands)	12"	12.129"	1.2"	0"
Invert 3										
Invert 4										
Invert 5										
Invert 6										
Invert 7										
Invert 8										

RIGHT-SIDE UP VIEW (int. dimensions)

UPSIDE-DOWN VIEW (int. dimensions)

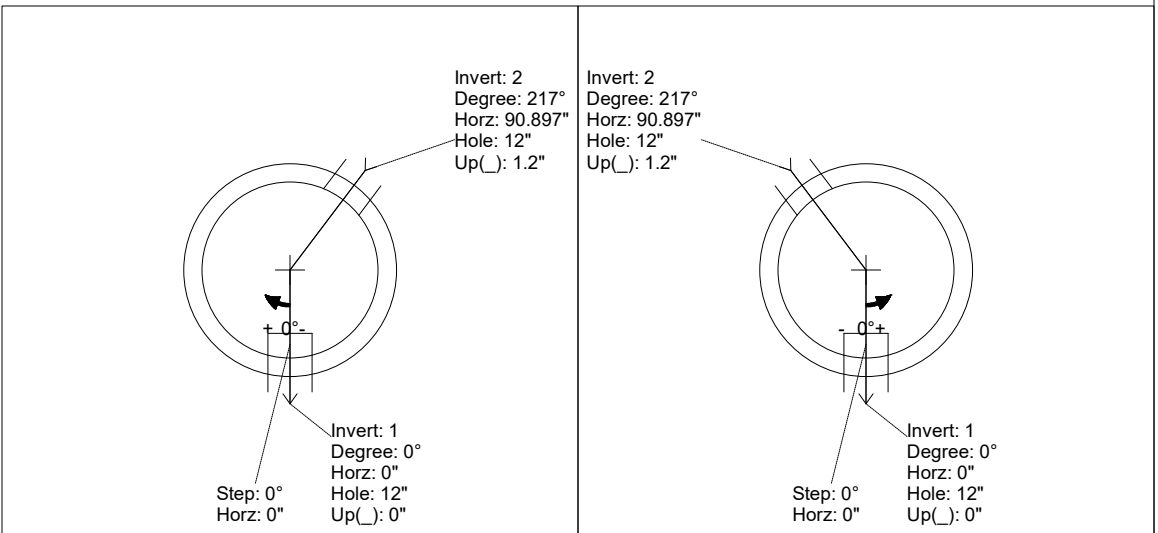

INSIDE WALL DIMENSIONS

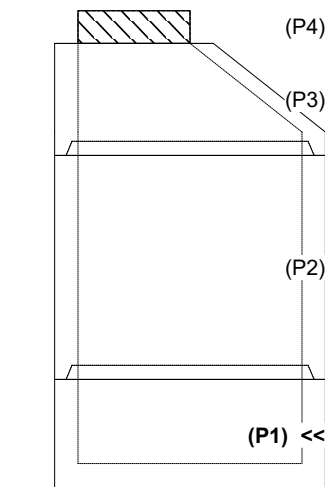
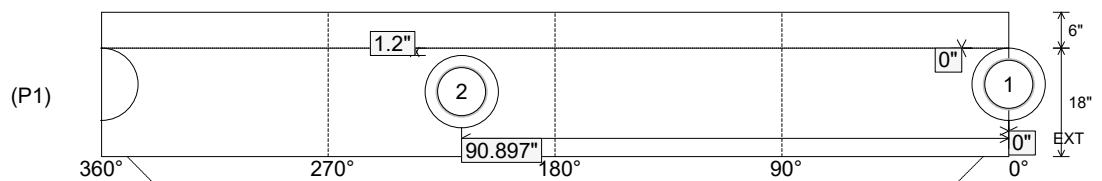

Coating (Int): Coating (Ext):	Seam Up: Tongue Seam Dn: n/a	Wall Thickness: 5" Floor Height: 6"	Height (Int): 18" Height (Ext): 24"	Weight (Net): 2492 lb Volume (Net): 0.64cu.yd
----------------------------------	---------------------------------	--	--	--