

Job Name: 25-4590 Uhlhorn Sewer Repairs
 Job Location: Evansville, IN
 Contractor: Bowen Engineering Corporation

Plant: Beaver Dam
 5/11/2026 10:20:07 AM

Tech: S. Felletter
 PC: A. Chambers



Structure ID: 100 (6)

P1 MH060BAVFCDARED

MH BASE Custom Ht, w/ConBlock-CDA Red T/n

- P6) 24" - CASTING HEIGHT - 7" 0 lb
- P5) 48" - ECC CONE w/ 24" HOLE, w/ConBlock-CDA Red F/G - 30" 1961 lb
- P4) 48" - MH RISER w/ConBlock-CDA Red T/G - 72" 5030 lb
- P3) 48" - MH RISER w/ConBlock-CDA Red T/G - 72" 5030 lb
- P2) 60" - MH TRANS. SLAB ECC w/ConBlock-CDA Red T/G - 15" 2204 lb
- P1) 60" - MH BASE Custom Ht, w/ConBlock-CDA Red T/n - 67" 9162 lb
- 1) JOINT WRAP - 0.065"x6"x50' CONSEAL CS212 0 lb
- 1) JOINT WRAP PRIMER - CONSEAL CS-75 (1 gal.) 0 lb
- 1) 60" - MH INVERT CHANNEL EWSU w/ConBlock-CDA Red - FULL HEIGHT 2962 lb
- 1) CASTING - HOE MC-315 F/C Sanitary 258 lb
- 1) 60" - Conseal CS-102 1.00" (Double) 0 lb
- 3) 48" - Conseal CS-102 1.00" (Double) 0 lb
- 1) Kor-N-Seal2 - S206-30 6 lb
- 1) Kor-N-Seal2 - S206-22L 6 lb

Structure Notes:
 1. PER ASTM C478 SPECIFICATIONS.
 2. CONCRETE = 4,000 PSI AT 28 DAYS.
 3. CASTING BY ICAST (HOE MC-315 F/C "SANITARY").
 4. NO STEPS.

 REINFORCING PER ASTM A615 (GRADE 60).
 - TOP SLAB (As .31) #5 BARS AT 6" C.C.E.W.
 - RISER/WALLS (As .18)
 - FLOOR (As .37) #5 BARS AT 10" C.C.E.W.

Structure Total: 26621 lb

Rim: 379.83' Rim to Invert: 21.69' Slack: 0.28" Sump: 3" Step Position:

Position	Elev	Angle	Ext. (cw)	Pipe	Pipe OD	Connector	Hole	Horz Size	Up (↓)	Offset
Invert 1	358.14'	0°	0"	24" PVC C900	25.8"	Kor-N-Seal2 S206-30	30"	31.416"	0"	0"
Invert 2	358.24'	270°	169.646"	18" PVC C900	19.5"	Kor-N-Seal2 S206-22L	22"	22.525"	2.2"	0"
Invert 3										
Invert 4										
Invert 5										
Invert 6										
Invert 7										
Invert 8										

RIGHT-SIDE UP VIEW (int. dimensions)

UPSIDE-DOWN VIEW (int. dimensions)

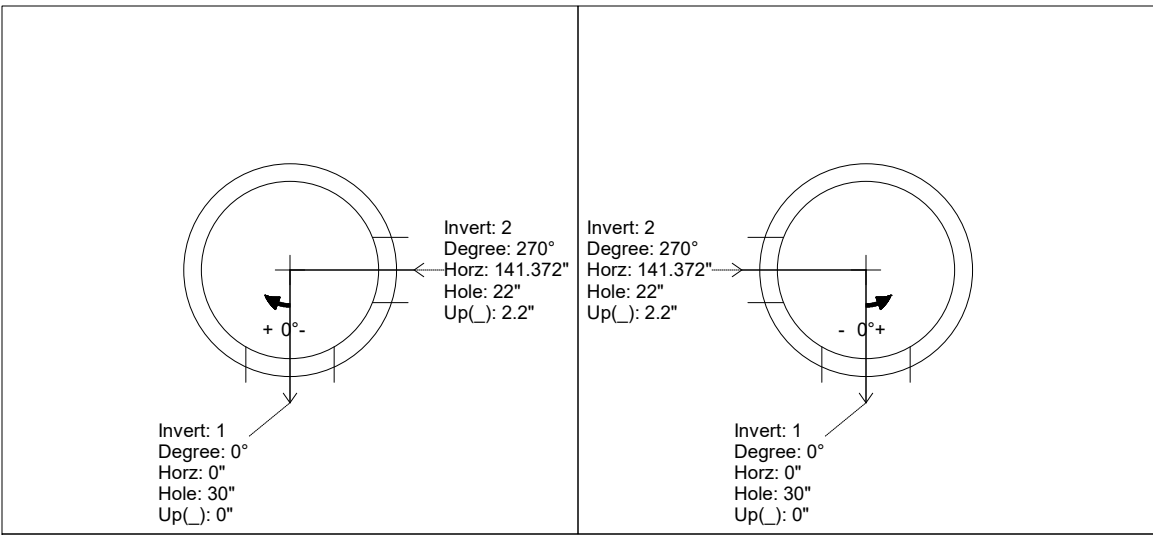
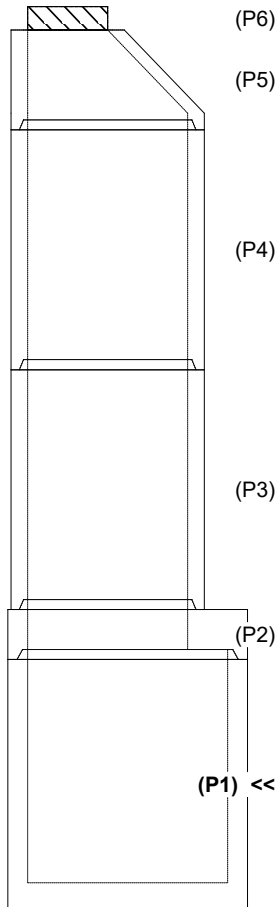

INSIDE WALL DIMENSIONS

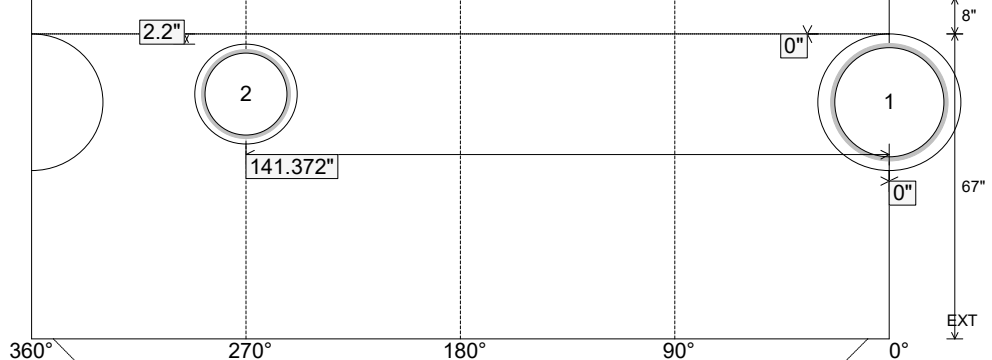

Coating (Int): Coating (Ext):	Seam Up: Tongue Seam Dn: n/a	Wall Thickness: 6" Floor Height: 8"	Height (Int): 67" Height (Ext): 75"	Weight (Net): 9162 lb Volume (Net): 2.34cu.yd
----------------------------------	---------------------------------	--	--	--

Job Name: 25-4590 Uhlhorn Sewer Repairs
 Job Location: Evansville, IN
 Contractor: Bowen Engineering Corporation

Plant: Beaver Dam
 5/11/2026 10:20:07 AM

Tech: S. Felletter
 PC: A. Chambers



Structure ID: 100 (6)

P1 MH060BAVFCDARED

MH BASE Custom Ht, w/ConBlock-CDA Red T/n

- P6) 24" - CASTING HEIGHT - 7" 0 lb
- P5) 48" - ECC CONE w/ 24" HOLE, w/ConBlock-CDA Red F/G - 30" 1961 lb
- P4) 48" - MH RISER w/ConBlock-CDA Red T/G - 72" 5030 lb
- P3) 48" - MH RISER w/ConBlock-CDA Red T/G - 72" 5030 lb
- P2) 60" - MH TRANS. SLAB ECC w/ConBlock-CDA Red T/G - 15" 2204 lb
- P1) 60" - MH BASE Custom Ht, w/ConBlock-CDA Red T/n - 67" 9162 lb
- 1) JOINT WRAP - 0.065"x6"x50' CONSEAL CS212 0 lb
- 1) JOINT WRAP PRIMER - CONSEAL CS-75 (1 gal.) 0 lb
- 1) 60" - MH INVERT CHANNEL EWSU w/ConBlock-CDA Red - FULL HEIGHT 2962 lb
- 1) CASTING - HOE MC-315 F/C Sanitary 258 lb
- 1) 60" - Conseal CS-102 1.00" (Double) 0 lb
- 3) 48" - Conseal CS-102 1.00" (Double) 0 lb
- 1) Kor-N-Seal2 - S206-30 6 lb
- 1) Kor-N-Seal2 - S206-22L 6 lb

- Structure Notes:**
1. PER ASTM C478 SPECIFICATIONS.
 2. CONCRETE = 4,000 PSI AT 28 DAYS.
 3. CASTING BY ICAST (HOE MC-315 F/C "SANITARY").
 4. NO STEPS.

REINFORCING PER ASTM A615 (GRADE 60).
 - TOP SLAB (As .31) #5 BARS AT 6" C.C.E.W.
 - RISER/WALLS (As .18)
 - FLOOR (As .37) #5 BARS AT 10" C.C.E.W.

**Invert channel drawing
 Full height invert
 EWSU invert required**

Structure Total: 26621 lb

Rim: 379.83' Rim to Invert: 21.69' Slack: 0.28" Sump: 3" Step Position:

Position	Elev	Angle	Ext. (cw)	Pipe	Pipe OD	Connector	Hole	Horz Size	Up ()	Offset
Invert 1	358.14'	0°	0"	24" PVC C900	25.8"	Kor-N-Seal2 S206-30	30"	31.416"	0"	0"
Invert 2	358.24'	270°	169.646"	18" PVC C900	19.5"	Kor-N-Seal2 S206-22L	22"	22.525"	2.2"	0"
Invert 3										
Invert 4										
Invert 5										
Invert 6										
Invert 7										
Invert 8										

RIGHT-SIDE UP VIEW (int. dimensions)

UPSIDE-DOWN VIEW (int. dimensions)

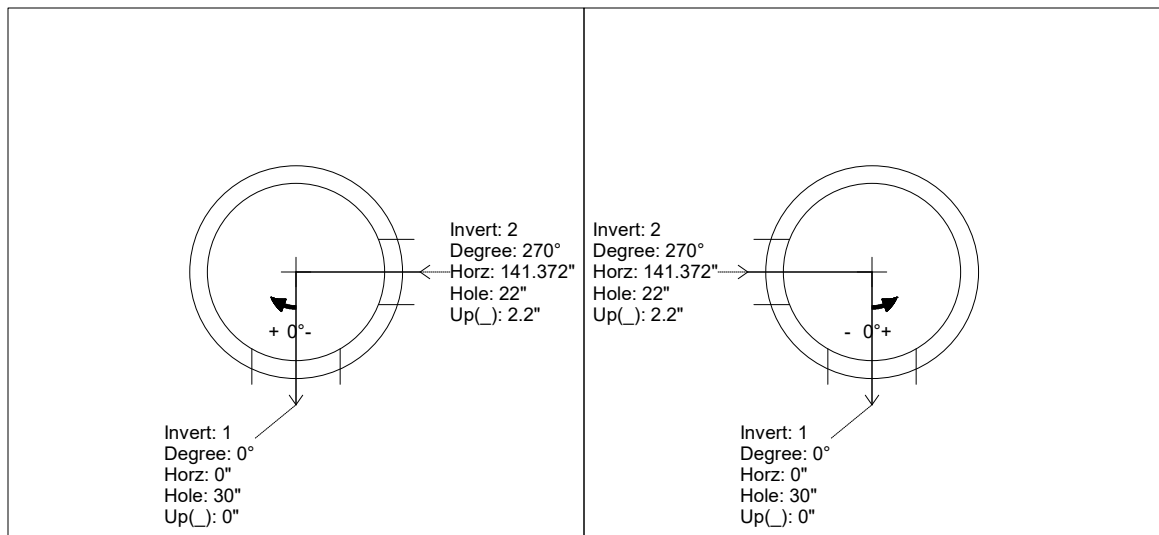
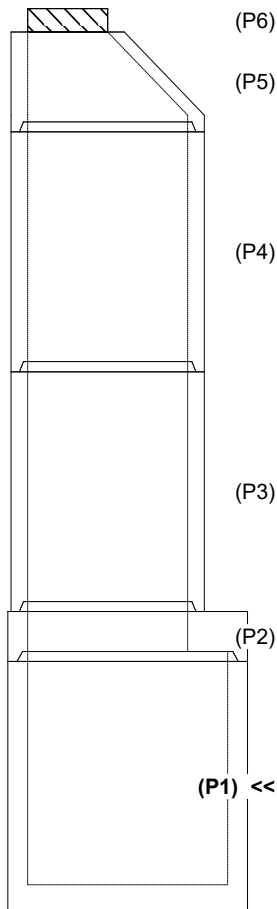

INSIDE WALL DIMENSIONS

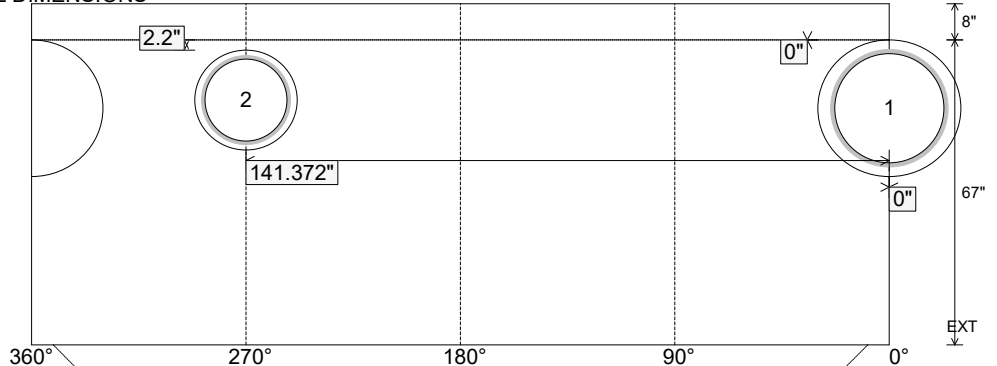

Coating (Int): Coating (Ext):	Seam Up: Tongue Seam Dn: n/a	Wall Thickness: 6" Floor Height: 8"	Height (Int): 67" Height (Ext): 75"	Weight (Net): 9162 lb Volume (Net): 2.34cu.yd
----------------------------------	---------------------------------	--	--	--