

Job Name: 25-3310 - Mammoth Cave NP-MACA 12  
 Job Location: Mammoth Cave, KY  
 Contractor: Phillips Brothers

Plant: 100  
 5/5/2026 5:08:09 PM

Tech: J. Horsley - F  
 PC: C. Goff



**Structure ID: CB1**

**P1 BX3048-08W08F-BAVF**

**BOX BASE 8inW, 8inF, Variable Ht F/n**

- P2) 30" x 48" - CASTING HEIGHT - 8"
- P1) 30" x 48" - BOX BASE 8inW, 8inF, Variable Ht - 49"
- 1) SECONDARY POUR - WALLS
- 1) 30" x 48" - Conseal CS-102 1.00"
- 2) Hole - 34

0 lb  
 6941 lb  
 0 lb  
 0 lb  
 0 lb  
 0 lb  
 -----  
 Structure Total: 6941 lb

Structure Notes:

1. PER ASTM C913 SPECIFICATIONS.
2. CONCRETE = 4,000 PSI AT 28 DAYS.
3. NO INVERT CHANNEL.
4. CASTING SUPPLIED BY OTHERS - NEENAH R-3287-15

REINFORCING PER ASTM A615 (GRADE 60).  
 - WALLS (As .12) #5 BARS AT 6" C.C.E.W.  
 - FLOOR (As .12) #5 BARS AT 6" C.C.E.W.

Rim: 739.04' Rim to Invert: 4.79' Slack: 0.48" Sump: 0" Step Position:

Position	Elev	Angle	Ext. (cw)	Pipe	Pipe OD	Connector	Hole	Horz Size	Up ( )	Offset
Invert 1	734.25'	90°	32"	24" RCP B WALL	30"	Hole 34	34"	34"	-3"	0"
Invert 2	734.9'	270°	32"	24" RCP B WALL	30"	Hole 34	34"	34"	4.75"	0"
Invert 3										
Invert 4										
Invert 5										
Invert 6										
Invert 7										
Invert 8										

RIGHT-SIDE UP VIEW (int. dimensions)

UPSIDE-DOWN VIEW (int. dimensions)

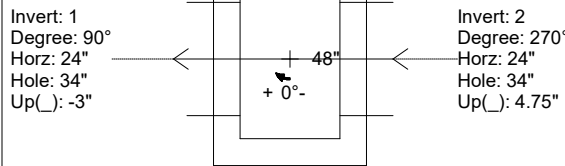
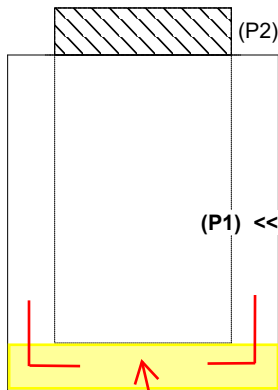

**1ST POUR (FLOOR) = 1,976 LBS  
 2ND POUR (WALLS) = 4,965 LBS**

INSIDE WALL DIMENSIONS

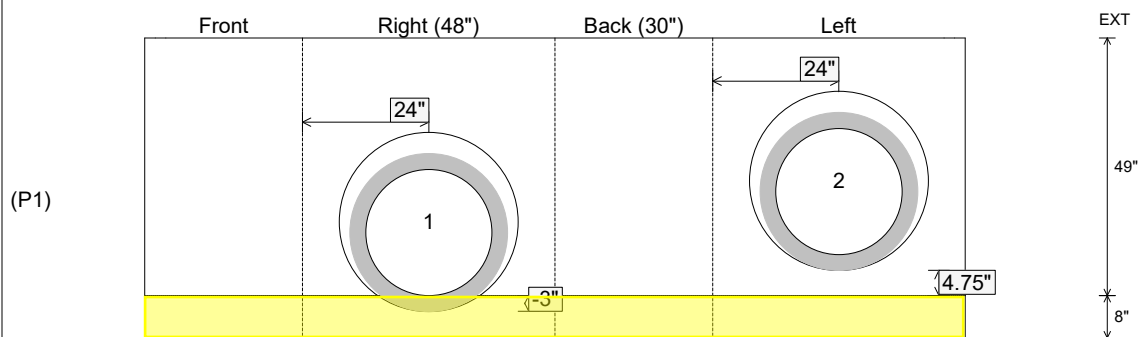

**1ST POUR (FLOOR)  
 STUB #5 L BARS OUT  
 TOP FLOOR, SPA AT  
 12" C/C FOR  
 CONNECTING WALLS**

Coating (Int):  
 Coating (Ext):

Seam Up: Flat  
 Seam Dn: n/a

Wall Thickness: 8"  
 Floor Height: 8"

Height (Int): 49"  
 Height (Ext): 57"

Weight (Net): 6941 lb  
 Volume (Net): 1.77cu.yd

Job Name: 25-3310 - Mammoth Cave NP-MACA 12  
 Job Location: Mammoth Cave , KY  
 Contractor: Phillips Brothers

Plant: 100  
 5/5/2026 5:08:09 PM

Tech: J. Horsley - F  
 PC: C. Goff



**Structure ID: CB1**

**P1 BX3048-08W08F-BAVF**

**BOX BASE 8inW, 8inF, Variable Ht F/n**

- P2) 30" x 48" - CASTING HEIGHT - 8"
- P1) 30" x 48" - BOX BASE 8inW, 8inF, Variable Ht - 49"
- 1) SECONDARY POUR - WALLS
- 1) 30" x 48" - Conseal CS-102 1.00"
- 2) Hole - 34

0 lb  
 6941 lb  
 0 lb  
 0 lb  
 0 lb  
 0 lb  
 -----  
 Structure Total: 6941 lb

Structure Notes:

1. PER ASTM C913 SPECIFICATIONS.
2. CONCRETE = 4,000 PSI AT 28 DAYS.
3. NO INVERT CHANNEL.
4. CASTING SUPPLIED BY OTHERS - NEENAH R-3287-15

REINFORCING PER ASTM A615 (GRADE 60).  
 - WALLS (As .12) #5 BARS AT 6" C.C.E.W.  
 - FLOOR (As .12) #5 BARS AT 6" C.C.E.W.

Rim: 739.04' Rim to Invert: 4.79' Slack: 0.48" Sump: 0" Step Position:

Position	Elev	Angle	Ext. (cw)	Pipe	Pipe OD	Connector	Hole	Horz Size	Up ( )	Offset
Invert 1	734.25'	90°	32"	24" RCP B WALL	30"	Hole 34	34"	34"	-3"	0"
Invert 2	734.9'	270°	32"	24" RCP B WALL	30"	Hole 34	34"	34"	4.75"	0"
Invert 3										
Invert 4										
Invert 5										
Invert 6										
Invert 7										
Invert 8										

RIGHT-SIDE UP VIEW (int. dimensions)

UPSIDE-DOWN VIEW (int. dimensions)

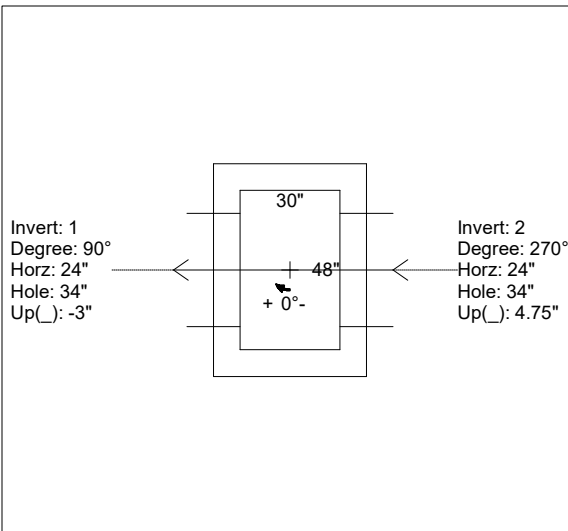

**1ST POUR (FLOOR) = 1,976 LBS  
 2ND POUR (WALLS) = 4,965 LBS**

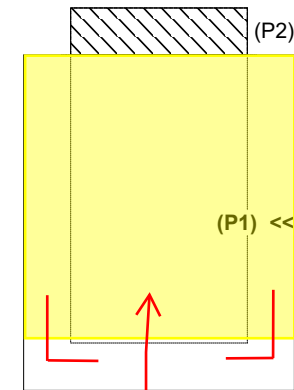

**2ND POUR (WALLS)**

INSIDE WALL DIMENSIONS

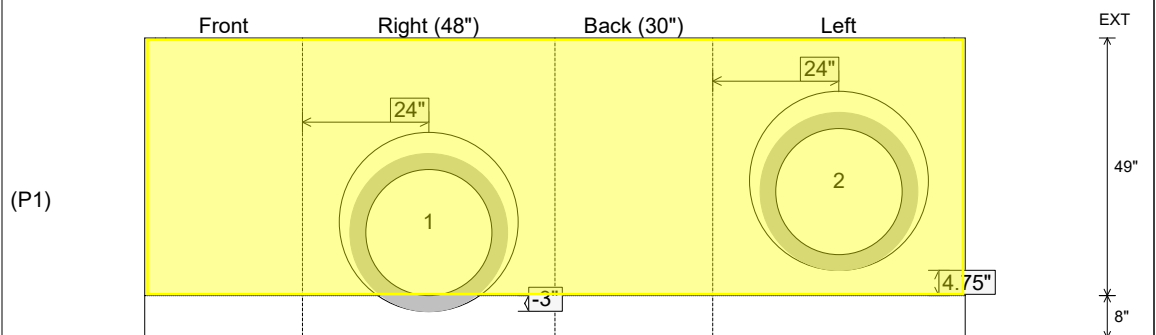

Coating (Int):  
 Coating (Ext):

Seam Up: Flat  
 Seam Dn: n/a

Wall Thickness: 8"  
 Floor Height: 8"

Height (Int): 49"  
 Height (Ext): 57"

Weight (Net): 6941 lb  
 Volume (Net): 1.77cu.yd