

Job Name: 25-3310 - Mammoth Cave NP-MACA 12
 Job Location: Mammoth Cave , KY
 Contractor: Phillips Brothers

Plant: 100

Tech: J. Horsley - F

5/5/2026 5:08:10 PM

PC: C. Goff



Structure ID: CB19

P1 BX3048-08W08F-BAVF

BOX BASE 8inW, 8inF, Variable Ht F/n

- P2) 30" x 48" - CASTING HEIGHT - 8"
- P1) 30" x 48" - BOX BASE 8inW, 8inF, Variable Ht - 39"
- 1) SECONDARY POUR - WALLS
- 1) 30" x 48" - Conseal CS-102 1.00"
- 1) Hole - 26
- 1) Hole - 22

0 lb
 6287 lb
 0 lb
 0 lb
 0 lb
 0 lb
 0 lb

 Structure Total: 6287 lb

Structure Notes:

1. PER ASTM C913 SPECIFICATIONS.
2. CONCRETE = 4,000 PSI AT 28 DAYS.
3. NO INVERT CHANNEL.
4. CASTING SUPPLIED BY OTHERS - NEENAH R-3287-15

REINFORCING PER ASTM A615 (GRADE 60).
 - WALLS (As .12) #5 BARS AT 6" C.C.E.W.
 - FLOOR (As .12) #5 BARS AT 6" C.C.E.W.

Rim: 740.57' Rim to Invert: 3.96' Slack: 0.52' Sump: 0' Step Position:

Position	Elev	Angle	Ext. (cw)	Pipe	Pipe OD	Connector	Hole	Horz Size	Up ()	Offset
Invert 1	736.61'	0°	23"	18" RCP B WALL	23"	Hole 26	26"	26"	-2.5"	0"
Invert 2	736.61'	90°	32"	15" RCP B WALL	19.5"	Hole 22	22"	22"	-2.25"	0"
Invert 3										
Invert 4										
Invert 5										
Invert 6										
Invert 7										
Invert 8										

RIGHT-SIDE UP VIEW (int. dimensions)

UPSIDE-DOWN VIEW (int. dimenions)

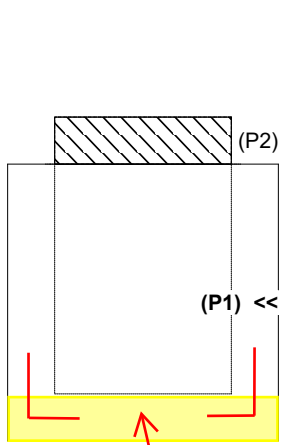

**1ST POUR (FLOOR) = 1,976 LBS
 2ND POUR (WALLS) = 4,311 LBS**

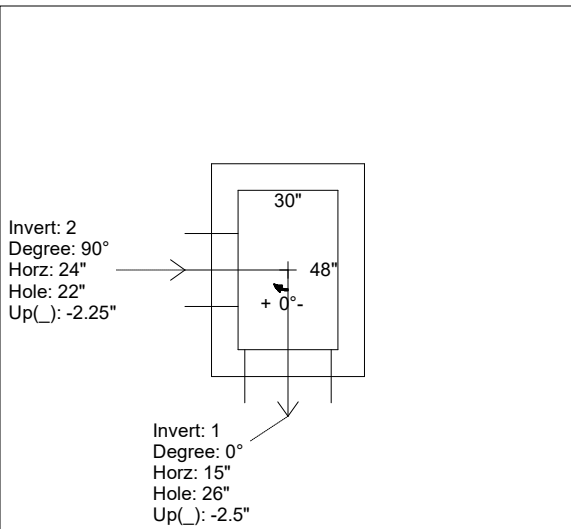

**1ST POUR (FLOOR)
 STUB #5 L BARS OUT
 TOP FLOOR, SPA AT
 12" C/C FOR
 CONNECTING WALLS**

INSIDE WALL DIMENSIONS

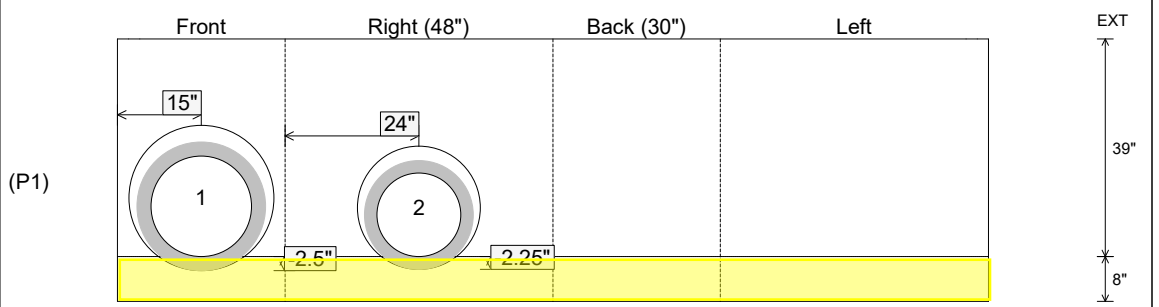

Coating (Int): Coating (Ext):	Seam Up: Flat Seam Dn: n/a	Wall Thickness: 8" Floor Height: 8"	Height (Int): 39" Height (Ext): 47"	Weight (Net): 6287 lb Volume (Net): 1.61cu.yd
----------------------------------	-------------------------------	--	--	--

Job Name: 25-3310 - Mammoth Cave NP-MACA 12
 Job Location: Mammoth Cave , KY
 Contractor: Phillips Brothers

Plant: 100
 5/5/2026 5:08:10 PM

Tech: J. Horsley - F
 PC: C. Goff



Structure ID: CB19

P1 BX3048-08W08F-BAVF

BOX BASE 8inW, 8inF, Variable Ht F/n

- P2) 30" x 48" - CASTING HEIGHT - 8"
- P1) 30" x 48" - BOX BASE 8inW, 8inF, Variable Ht - 39"
- 1) SECONDARY POUR - WALLS
- 1) 30" x 48" - Conseal CS-102 1.00"
- 1) Hole - 26
- 1) Hole - 22

0 lb
 6287 lb
 0 lb
 0 lb
 0 lb
 0 lb
 0 lb

 Structure Total: 6287 lb

Structure Notes:

1. PER ASTM C913 SPECIFICATIONS.
2. CONCRETE = 4,000 PSI AT 28 DAYS.
3. NO INVERT CHANNEL.
4. CASTING SUPPLIED BY OTHERS - NEENAH R-3287-15

REINFORCING PER ASTM A615 (GRADE 60).
 - WALLS (As .12) #5 BARS AT 6" C.C.E.W.
 - FLOOR (As .12) #5 BARS AT 6" C.C.E.W.

Rim: 740.57' Rim to Invert: 3.96' Slack: 0.52" Sump: 0" Step Position:

Position	Elev	Angle	Ext. (cw)	Pipe	Pipe OD	Connector	Hole	Horz Size	Up ()	Offset
Invert 1	736.61'	0°	23"	18" RCP B WALL	23"	Hole 26	26"	26"	-2.5"	0"
Invert 2	736.61'	90°	32"	15" RCP B WALL	19.5"	Hole 22	22"	22"	-2.25"	0"
Invert 3										
Invert 4										
Invert 5										
Invert 6										
Invert 7										
Invert 8										

RIGHT-SIDE UP VIEW (int. dimensions)

UPSIDE-DOWN VIEW (int. dimenions)

**1ST POUR (FLOOR) = 1,976 LBS
 2ND POUR (WALLS) = 4,311 LBS**

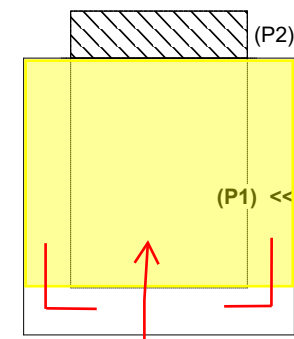
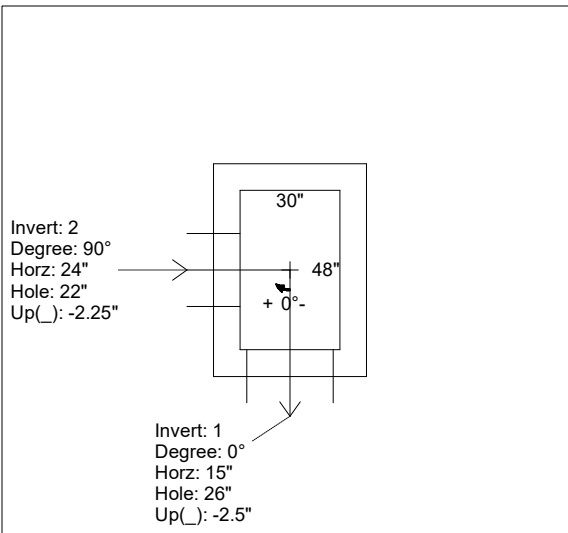

2ND POUR (WALLS)

INSIDE WALL DIMENSIONS

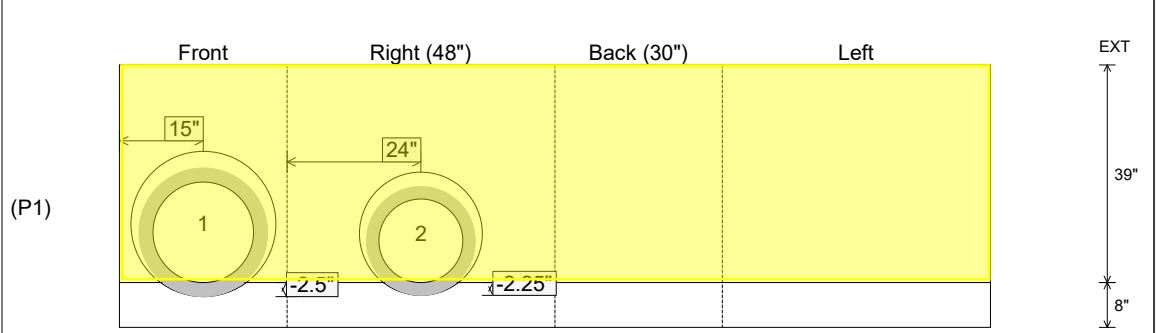

Coating (Int):
 Coating (Ext):

Seam Up: Flat
 Seam Dn: n/a

Wall Thickness: 8"
 Floor Height: 8"

Height (Int): 39"
 Height (Ext): 47"

Weight (Net): 6287 lb
 Volume (Net): 1.61cu.yd