

Job Name: 25-4508 - Georgetown Commons Target
 Job Location: Georgetown, KY
 Contractor: Winwater Hartford KY Co.

Plant: 100
 5/28/2026 11:25:38 AM

Tech: Jared - F
 PC: A. Chambers



Structure ID: 103 (26)

P1 MH048BA48

MH BASE T/n

- P3) 24" x 30" - CASTING HEIGHT - 6"
- P2) 48" - MH FLAT TOP w/24"x30" Hole F/G - 12"
- P1) 48" - MH BASE T/n - 48"
- 1) CASTING - HOE 360 Set (F/G/H)
- 1) 48" - Conseal CS-102 1.00"
- 1) 24" x 30" - Conseal CS-102 1.00"
- 2) Hole - 30
- 1) Hole - 16

0 lb
 1935 lb
 3966 lb
 362 lb
 0 lb
 0 lb
 0 lb
 0 lb
 0 lb

 Structure Total: 6263 lb

Structure Notes:
 1. PER ASTM C478 SPECIFICATIONS.
 2. CONCRETE = 4,000 PSI AT 28 DAYS.
 3. NO STEPS AND NO INVERT CHANNEL.
 4. CASTING BY ICAST (HOE 360 SET (F/G/H)).

REINFORCING PER ASTM A615 (GRADE 60).
 - TOP SLAB (As .62) #5 BARS AT 6" C.C.E.W..
 - RISER/WALLS (As .12)
 - FLOOR (As .31) #5 BARS AT 12" C.C.E.W.

Rim: 873.85' Rim to Invert: 5.4' Slack: 0.7" Sump: 1.9" Step Position:

Position	Elev	Angle	Ext. (cw)	Pipe	Pipe OD	Connector	Hole	Horz Size	Up ()	Offset
Invert 1	868.45'	0°	0"	24" HDPE	27.8"	Hole 30	30"	32.406"	0"	0"
Invert 2	868.45'	88°	44.5"	12" HDPE	14.5"	Hole 16	16"	16.312"	0.625"	0"
Invert 3	868.45'	182°	92.125"	24" HDPE	27.8"	Hole 30	30"	32.406"	0"	0"
Invert 4										
Invert 5										
Invert 6										
Invert 7										
Invert 8										

RIGHT-SIDE UP VIEW (int. dimensions)

UPSIDE-DOWN VIEW (int. dimensions)

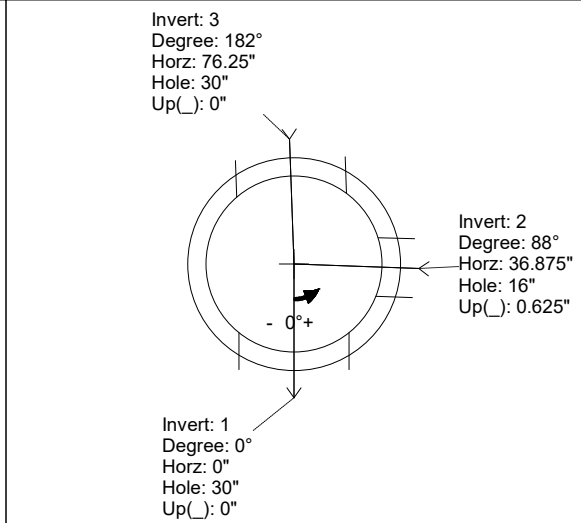
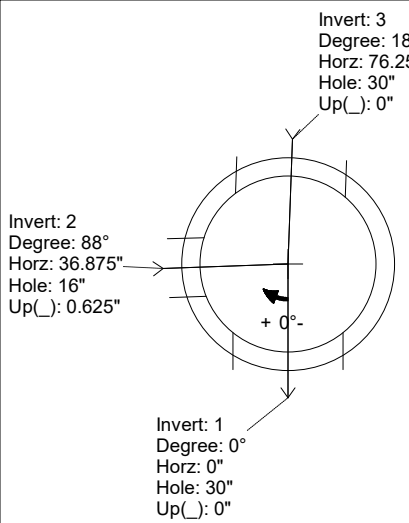
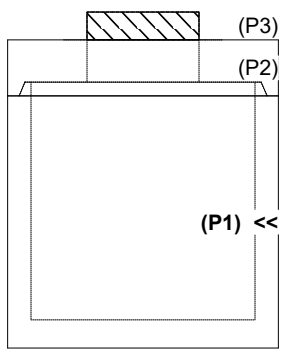

INSIDE WALL DIMENSIONS

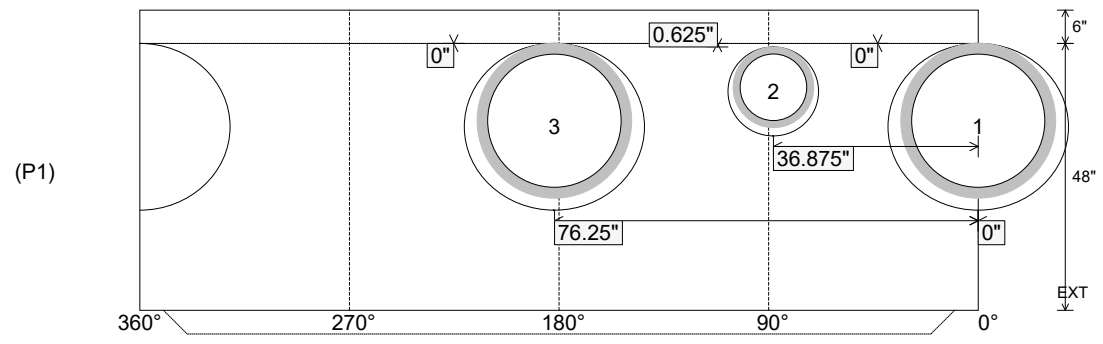

Coating (Int): Coating (Ext):	Seam Up: Tongue Seam Dn: n/a	Wall Thickness: 5" Floor Height: 6"	Height (Int): 48" Height (Ext): 54"	Weight (Net): 3966 lb Volume (Net): 1.01cu.yd
----------------------------------	---------------------------------	--	--	--