

Job Name: 23-2404 Hampton Hills (Phase 1)
 Job Location: Richmond, KY
 Contractor: Seven Earthmovers LLC

Plant: 100
 5/19/2026 12:59:28 PM

Tech: J. Horsley
 PC: C. Golf



Structure ID: SSMH AA-8

P1 MH048BAVF

MH BASE Custom Ht T/n

- P3) 24" - CASTING HEIGHT - 7"
- P2) 48" - ECC CONE w/ 24" HOLE F/G - 30"
- P1) 48" - MH BASE Custom Ht T/n - 19"
- 1) 48" - MH INVERT CHANNEL - FULL HEIGHT
- 1) JOINT WRAP - 0.065"x6"x50' CONSEAL CS212
- 1) JOINT WRAP PRIMER - CONSEAL CS-75 (1 gal.)
- 1) CASTING - HOE MC-350 F/C Sanitary
- 1) 48" - Conseal CS-102 1.00" (Double)
- 1) PSX - 12-08 NYLO
- 1) PSX - 12-06 NYLO
- 4) MH Step ML-10-TDS-NCR - 10"

0 lb
 2050 lb
 2562 lb
 1440 lb
 0 lb
 0 lb
 305 lb
 0 lb
 8 lb
 8 lb
 0 lb

 Structure Total: 6373 lb

Structure Notes:
 1. PER ASTM C478 SPECIFICATIONS.
 2. CONCRETE = 4,000 PSI AT 28 DAYS.
 3. CASTING BY ICAST (HOE MC-350 F/C) SHIPPED LOOSE.

REINFORCING PER ASTM A615 (GRADE 60).
 - CONE (As .12)
 - RISER/WALLS (As .12)
 - FLOOR (As .31) #5 BARS AT 12" C.C.E.W.

Rim: 913.7' Rim to Invert: 4.5' Slack: 0" Sump: 2" Step Position: 0°

Position	Elev	Angle	Ext. (cw)	Pipe	Pipe OD	Connector	Hole	Horz Size	Up ()	Offset
Invert 1	909.2'	0°	0"	8" PVC SDR35	8.5"	PSX 12-08 NYLO	12"	12.129"	0"	0"
Invert 2	909.3'	225°	113.875"	6" PVC SDR35	6.25"	PSX 12-06 NYLO	12"	12.129"	0.25"	0"
Invert 3										
Invert 4										
Invert 5										
Invert 6										
Invert 7										
Invert 8										

RIGHT-SIDE UP VIEW (int. dimensions)

UPSIDE-DOWN VIEW (int. dimensions)

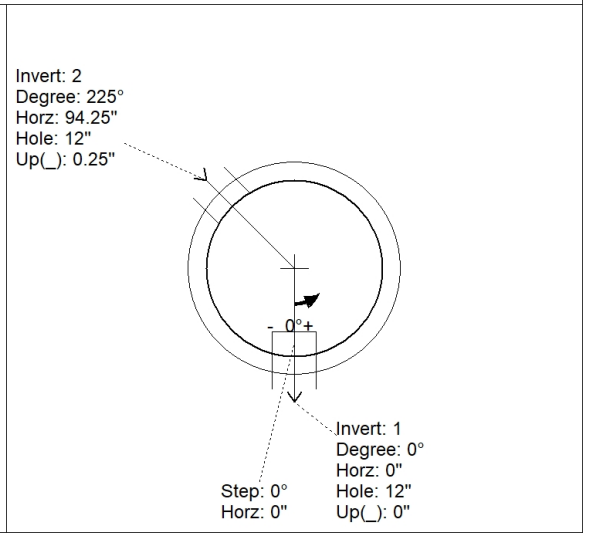
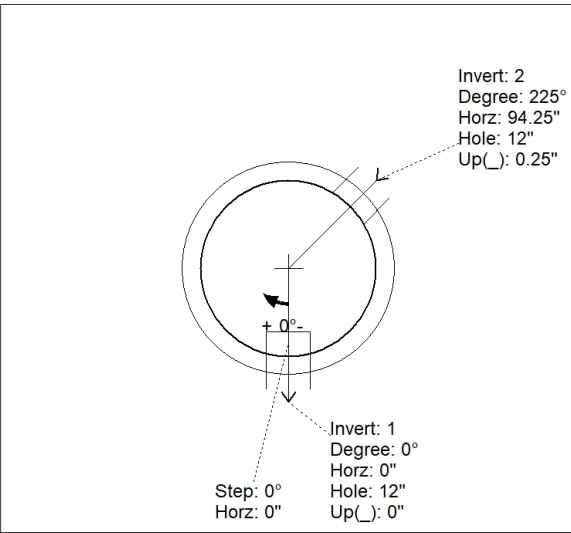
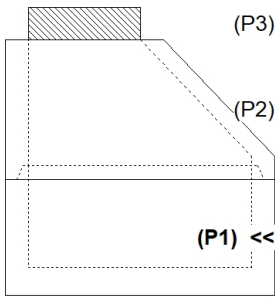

INSIDE WALL DIMENSIONS

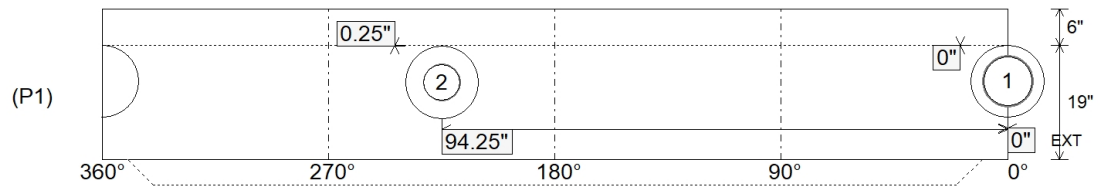

Coating (Int):
 Coating (Ext):

Seam Up: Tongue
 Seam Dn: n/a

Wall Thickness: 5"
 Floor Height: 6"

Height (Int): 19"
 Height (Ext): 25"

Weight (Net): 2562 lb
 Volume (Net): 0.65cu.yd

Job Name: 23-2404 Hampton Hills (Phase 1)
 Job Location: Richmond, KY
 Contractor: Seven Earthmovers LLC

Plant: 100

Tech: J. Horsley

5/19/2026 12:59:28 PM

PC: C. Golf



Structure ID: SSMH AA-8

P1A MH048BAVF

MH BASE Custom Ht T/n

- P3) 24" - CASTING HEIGHT - 7"
- P2) 48" - ECC CONE w/ 24" HOLE F/G - 30"
- P1) 48" - MH BASE Custom Ht T/n - 19"
- 1) 48" - MH INVERT CHANNEL - FULL HEIGHT
- 1) JOINT WRAP - 0.065"x6"x50' CONSEAL CS212
- 1) JOINT WRAP PRIMER - CONSEAL CS-75 (1 gal.)
- 1) CASTING - HOE MC-350 F/C Sanitary
- 1) 48" - Conseal CS-102 1.00" (Double)
- 1) PSX - 12-08 NYLO
- 1) PSX - 12-06 NYLO
- 4) MH Step ML-10-TDS-NCR - 10"

0 lb
 2050 lb
 2562 lb
 1440 lb
 0 lb
 0 lb
 305 lb
 0 lb
 8 lb
 8 lb
 0 lb

 Structure Total: 6373 lb

Structure Notes:

1. PER ASTM C478 SPECIFICATIONS.
2. CONCRETE = 4,000 PSI AT 28 DAYS.
3. CASTING BY ICAST (HOE MC-350 F/C) SHIPPED LOOSE.

REINFORCING PER ASTM A615 (GRADE 60).

- CONE (As .12)
- RISER/WALLS (As .12)
- FLOOR (As .31) #5 BARS AT 12" C.C.E.W.

Rim: 913.7' Rim to Invert: 4.5' Slack: 0" Sump: 2" Step Position: 0°

Position	Elev	Angle	Ext. (cw)	Pipe	Pipe OD	Connector	Hole	Horz Size	Up ()	Offset
Invert 1	909.2'	0°	0"	8" PVC SDR35	8.5"	PSX 12-08 NYLO	12"	12.129"	0"	0"
Invert 2	909.3'	225°	113.875"	6" PVC SDR35	6.25"	PSX 12-06 NYLO	12"	12.129"	0.25"	0"
Invert 3										
Invert 4										
Invert 5										
Invert 6										
Invert 7										
Invert 8										

RIGHT-SIDE UP VIEW (int. dimensions)

UPSIDE-DOWN VIEW (int. dimensions)

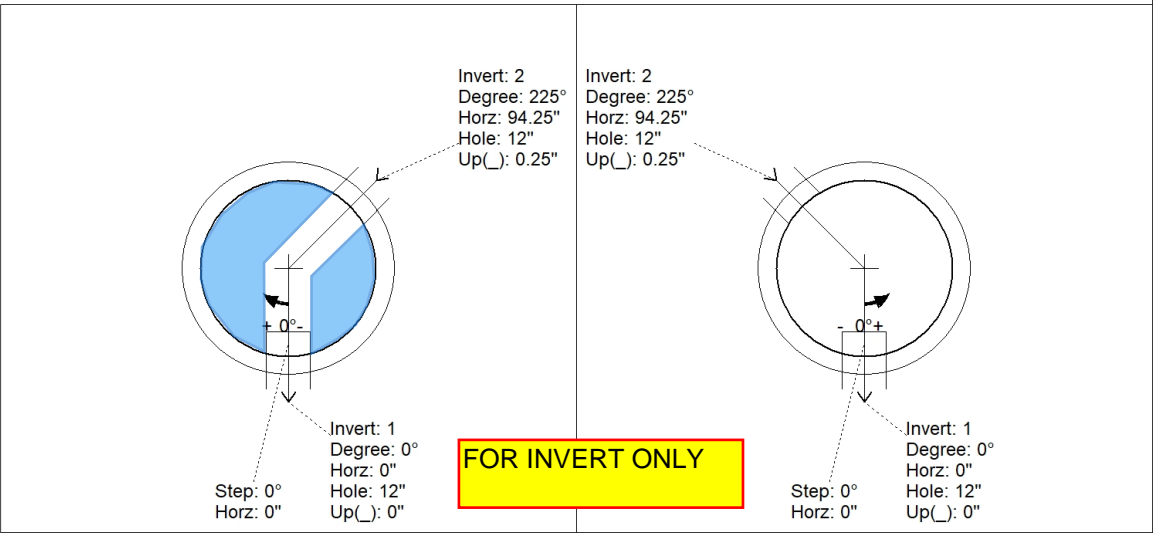
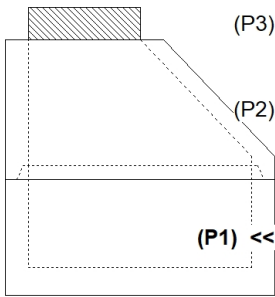

INSIDE WALL DIMENSIONS

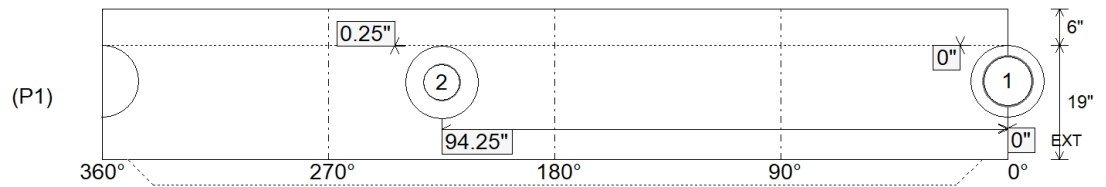

Coating (Int):
 Coating (Ext):

Seam Up: Tongue
 Seam Dn: n/a

Wall Thickness: 5"
 Floor Height: 6"

Height (Int): 19"
 Height (Ext): 25"

Weight (Net): 2562 lb
 Volume (Net): 0.65cu.yd