

Job Name: 25-4733 - The Paddock
 Job Location: Springfield, KY
 Contractor: Core & Main LP (Lou)

Plant: 100
 5/14/2026 1:08:53 PM

Tech: Jared - F
 PC: T. Lewis



Structure ID: SSWR-8

P1 MH048BA24

MH BASE T/n

P3) 24" - CASTING HEIGHT - 7"	0 lb
P2) 48" - MH FLAT TOP w/ 24" ECC Hole F/G - 12"	1561 lb
P1) 48" - MH BASE T/n - 24"	2959 lb
1) JOINT WRAP - 0.065"x6"x50' CONSEAL CS212	0 lb
1) JOINT WRAP PRIMER - CONSEAL CS-75 (1 gal.)	0 lb
1) 48" - MH INVERT CHANNEL - FULL HEIGHT	1440 lb
1) CASTING - HOE MC-315 F/C Sanitary	258 lb
1) 48" - Conseal CS-102 1.00" (Double)	0 lb
1) PSX - 12-06 NYLO	8 lb
1) MH Step ML-10-TDS-NCR - 10"	0 lb
Structure Total:	6226 lb

Structure Notes:
 1. PER ASTM C478 SPECIFICATIONS.
 2. CONCRETE = 4,000 PSI AT 28 DAYS.
 3. CASTING BY ICAST (HOE MC-315 F/C SANITARY).

 REINFORCING PER ASTM A615 (GRADE 60).
 - TOP SLAB = H2O LOADING.
 - RISER/WALLS (As .12)
 - FLOOR (As .31) #5 BARS AT 12" C.C.E.W.

Rim: 891.6' Rim to Invert: 3.35' Slack: 0.2" Sump: 3" Step Position: 180°

Position	Elev	Angle	Ext. (cw)	Pipe	Pipe OD	Connector	Hole	Horz Size	Up ()	Offset
Invert 1	888.25'	0°	0"	6" PVC C900	6.9"	PSX 12-06 NYLO	12"	12.129"	0"	0"
Invert 2										
Invert 3										
Invert 4										
Invert 5										
Invert 6										
Invert 7										
Invert 8										

RIGHT-SIDE UP VIEW (int. dimensions)

UPSIDE-DOWN VIEW (int. dimensions)

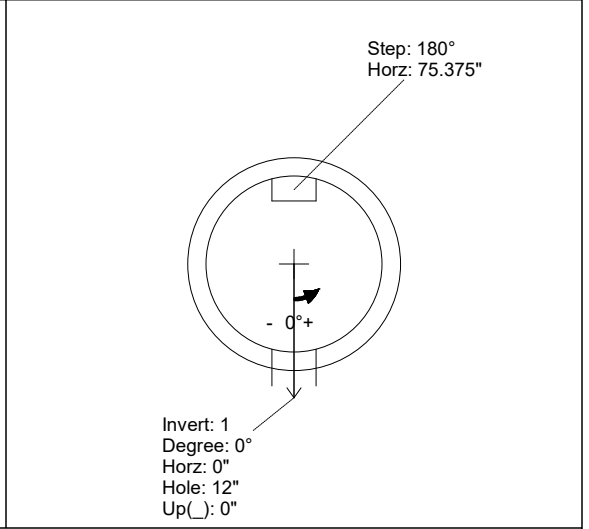
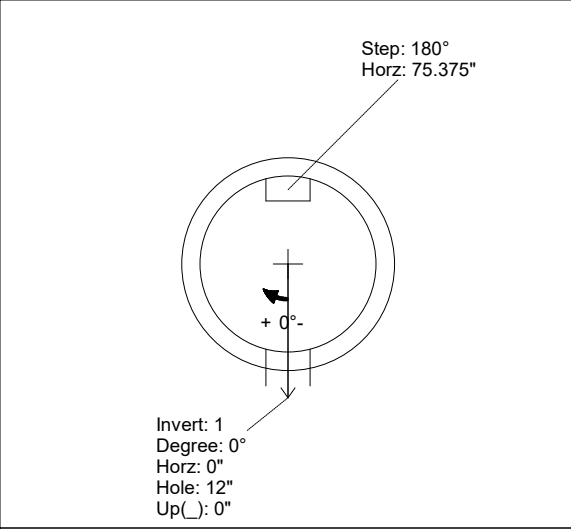
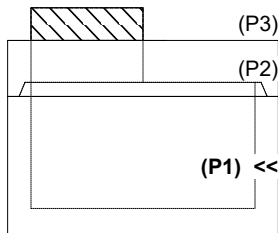

INSIDE WALL DIMENSIONS

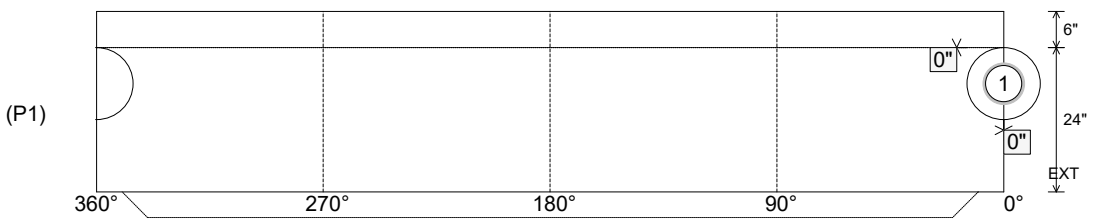

Coating (Int): Coating (Ext):	Seam Up: Tongue Seam Dn: n/a	Wall Thickness: 5" Floor Height: 6"	Height (Int): 24" Height (Ext): 30"	Weight (Net): 2959 lb Volume (Net): 0.76cu.yd
----------------------------------	---------------------------------	--	--	--

Job Name: 25-4733 - The Paddock
 Job Location: Springfield, KY
 Contractor: Core & Main LP (Lou)

Plant: 100
 5/14/2026 1:08:53 PM

Tech: Jared - F
 PC: T. Lewis



Structure ID: SSWR-8

P1 MH048BA24

MH BASE T/n

- P3) 24" - CASTING HEIGHT - 7"
- P2) 48" - MH FLAT TOP w/ 24" ECC Hole F/G - 12"
- P1) 48" - MH BASE T/n - 24"
- 1) JOINT WRAP - 0.065"x6"x50' CONSEAL CS212
- 1) JOINT WRAP PRIMER - CONSEAL CS-75 (1 gal.)
- 1) 48" - MH INVERT CHANNEL - FULL HEIGHT
- 1) CASTING - HOE MC-315 F/C Sanitary
- 1) 48" - Conseal CS-102 1.00" (Double)
- 1) PSX - 12-06 NYLO
- 1) MH Step ML-10-TDS-NCR - 10"

0 lb
 1561 lb
 2959 lb
 0 lb
 0 lb
 1440 lb
 258 lb
 0 lb
 8 lb
 0 lb

 Structure Total: 6226 lb

Structure Notes:
 1. PER ASTM C478 SPECIFICATIONS.
 2. CONCRETE = 4,000 PSI AT 28 DAYS.
 3. CASTING BY ICAST (HOE MC-315 F/C SANITARY).
 REINFORCING PER ASTM A615 (GRADE 60).
 - TOP SLAB = H2O LOADING.
 - RISER/WALLS (As .12)
 - FLOOR (As .31) #5 BARS AT 12" C.C.E.W.

Rim: 891.6' Rim to Invert: 3.35' Slack: 0.2" Sump: 3" Step Position: 180°

Position	Elev	Angle	Ext. (cw)	Pipe	Pipe OD	Connector	Hole	Horz Size	Up ()	Offset
Invert 1	888.25'	0°	0"	6" PVC C900	6.9"	PSX 12-06 NYLO	12"	12.129"	0"	0"
Invert 2										
Invert 3										
Invert 4										
Invert 5										
Invert 6										
Invert 7										
Invert 8										

RIGHT-SIDE UP VIEW (int. dimensions)

UPSIDE-DOWN VIEW (int. dimensions)

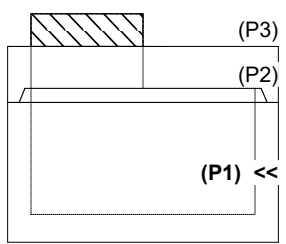
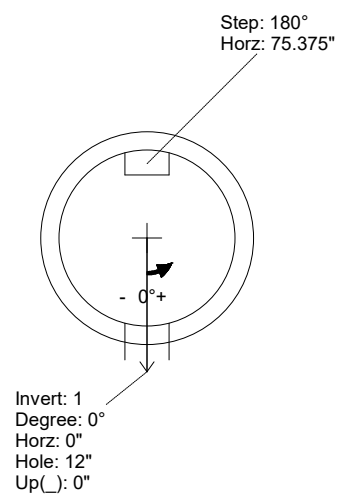
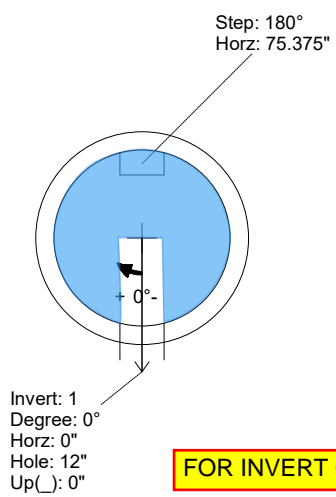

INSIDE WALL DIMENSIONS

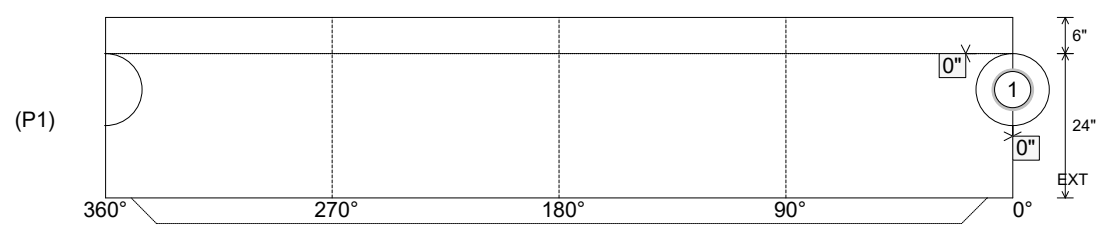

Coating (Int): Coating (Ext):	Seam Up: Tongue Seam Dn: n/a	Wall Thickness: 5" Floor Height: 6"	Height (Int): 24" Height (Ext): 30"	Weight (Net): 2959 lb Volume (Net): 0.76cu.yd
----------------------------------	---------------------------------	--	--	--