

Job Name: 24-4112 - Ohio River Service Area Rehab
 Job Location: Louisville, KY 40222
 Contractor: TRC, LLC

Plant: Beaver Dam, KY
 5/13/2026 2:57:20 PM

Tech: K. Cardwell
 PC: A. Wells



Structure ID: 956

P1 MH048BA24

MH BASE T/n

P3) 24" - CASTING HEIGHT - 7"	0 lb
P2) 48" - MH FLAT TOP w/ 24" ECC Hole F/G - 12"	1561 lb
P1) 48" - MH BASE T/n - 24"	2911 lb
1) JOINT WRAP PRIMER - CONSEAL CS-75 (1 gal.)	0 lb
1) JOINT WRAP - 0.065"x6"x50" CONSEAL CS212	0 lb
1) 48" - SAN. INV. CHANNEL - FULL HEIGHT	1440 lb
1) 48" - Conseal CS-102 1.00" (Double)	0 lb
1) 24" - Conseal CS-102 1.00" (Double)	0 lb
2) PSX - 12-08 NYLO	16 lb
1) MH Step ML-10-TDS-NCR - 10"	0 lb
Structure Total:	5928 lb

Structure Notes:
 STATION: 2+19.78 CLUB DR
 1. PER MSD & ASTM C-478 SPECIFICATIONS
 2. CONCRETE: 5,000 PSI AT 28 DAYS
 3. REINFORCEMENT: PER ASTM A615
 4. INVERT CHANNEL REQUIRED
 5. STEPS AT 225 DEGREES
 6. 7" CASTING SUPPLIED BY OTHERS

Rim: 659.9' Rim to Invert: 3.51' Slack: 2.12" Sump: 3" Step Position: 225°

Position	Elev	Angle	Ext. (cw)	Pipe	Pipe OD	Connector	Hole	Horz Size	Up ()	Offset
Invert 1	656.39'	0°	0"	8" PVC SDR35	8.5"	PSX 12-08 NYLO	12"	12.129"	1"	0"
Invert 2	656.49'	90°	45.5"	8" PVC SDR35	8.5"	PSX 12-08 NYLO	12"	12.129"	2.25"	0"
Invert 3										
Invert 4										
Invert 5										
Invert 6										
Invert 7										
Invert 8										

RIGHT-SIDE UP VIEW (int. dimensions)

UPSIDE-DOWN VIEW (int. dimenions)

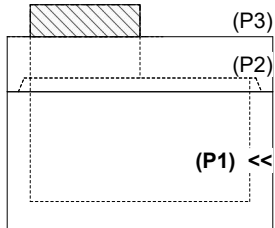
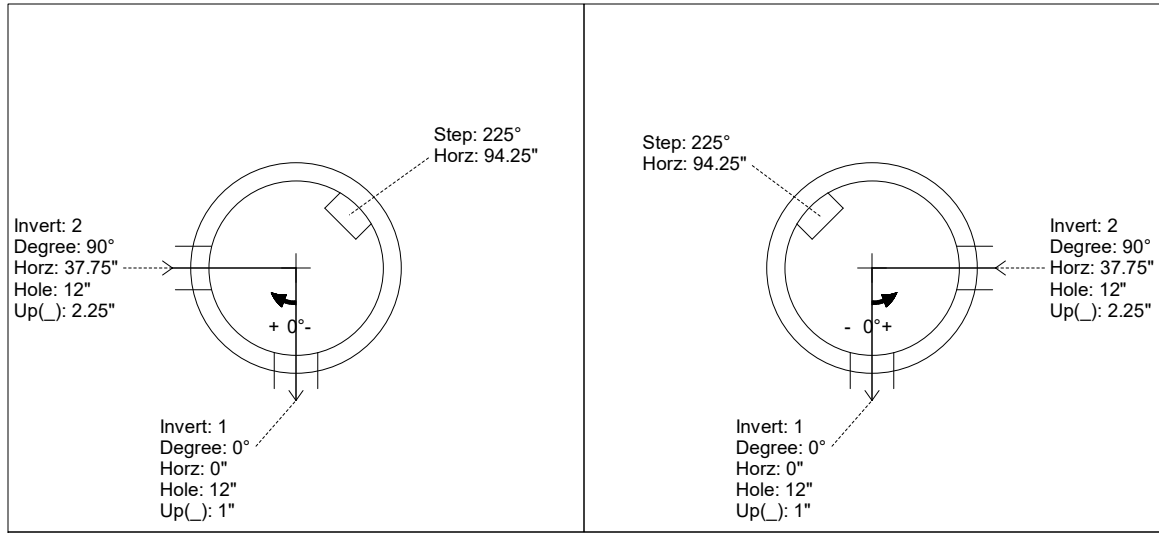

INSIDE WALL DIMENSIONS

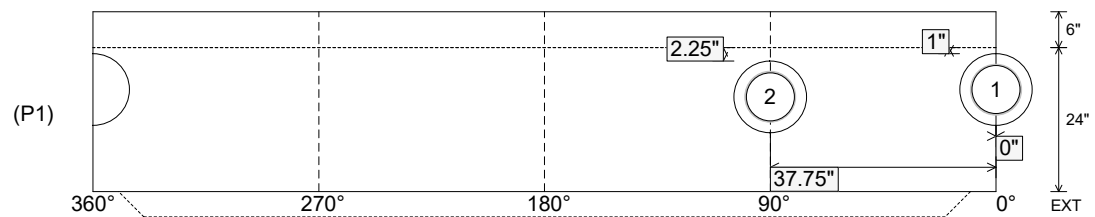

Coating (Int):
 Coating (Ext):

Seam Up: Tongue
 Seam Dn: n/a

Wall Thickness: 5"
 Floor Height: 6"

Height (Int): 24"
 Height (Ext): 30"

Weight (Net): 2911 lb
 Volume (Net): 0.74cu.yd

Job Name: 24-4112 - Ohio River Service Area Rehab
 Job Location: Louisville, KY 40222
 Contractor: TRC, LLC

Plant: Beaver Dam, KY

Tech: K. Cardwell

5/13/2026 2:57:20 PM

PC: A. Wells



Structure ID: 956

P1 MH048BA24

MH BASE T/n

- P3) 24" - CASTING HEIGHT - 7" 0 lb
- P2) 48" - MH FLAT TOP w/ 24" ECC Hole F/G - 12" 1561 lb
- P1) 48" - MH BASE T/n - 24" 2911 lb
- 1) JOINT WRAP PRIMER - CONSEAL CS-75 (1 gal.) 0 lb
- 1) JOINT WRAP - 0.065"x6"x50" CONSEAL CS212 0 lb
- 1) 48" - SAN. INV. CHANNEL - FULL HEIGHT 1440 lb
- 1) 48" - Conseal CS-102 1.00" (Double) 0 lb
- 1) 24" - Conseal CS-102 1.00" (Double) 0 lb
- 2) PSX - 12-08 NYLO 16 lb
- 1) MH Step ML-10-TDS-NCR - 10" 0 lb

Structure Total: 5928 lb

Structure Notes:

- STATION: 2+19.78 CLUB DR
1. PER MSD & ASTM C-478 SPECIFICATIONS
 2. CONCRETE: 5,000 PSI AT 28 DAYS
 3. REINFORCEMENT: PER ASTM A615
 4. INVERT CHANNEL REQUIRED
 5. STEPS AT 225 DEGREES
 6. 7" CASTING SUPPLIED BY OTHERS

Rim: 659.9' Rim to Invert: 3.51' Slack: 2.12" Sump: 3" Step Position: 225°

Position	Elev	Angle	Ext. (cw)	Pipe	Pipe OD	Connector	Hole	Horz Size	Up ()	Offset
Invert 1	656.39'	0°	0"	8" PVC SDR35	8.5"	PSX 12-08 NYLO	12"	12.129"	1"	0"
Invert 2	656.49'	90°	45.5"	8" PVC SDR35	8.5"	PSX 12-08 NYLO	12"	12.129"	2.25"	0"
Invert 3										
Invert 4										
Invert 5										
Invert 6										
Invert 7										
Invert 8										

RIGHT-SIDE UP VIEW (int. dimensions)

UPSIDE-DOWN VIEW (int. dimenions)

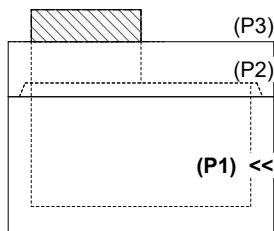
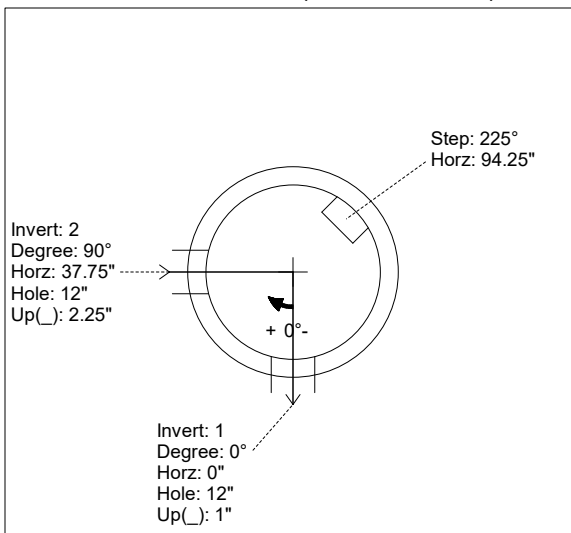

INVERT CHANNEL DRAWING

INSIDE WALL DIMENSIONS

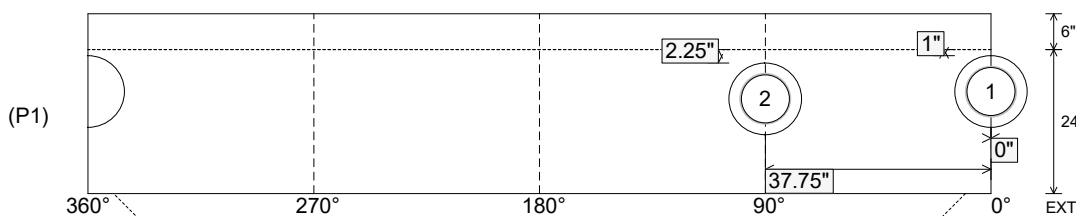

Coating (Int):
 Coating (Ext):

Seam Up: Tongue
 Seam Dn: n/a

Wall Thickness: 5"
 Floor Height: 6"

Height (Int): 24"
 Height (Ext): 30"

Weight (Net): 2911 lb
 Volume (Net): 0.74cu.yd