

Job Name: 24-4112 - Ohio River Service Area Rehab
 Job Location: Louisville, KY 40222
 Contractor: TRC, LLC

Plant: Beaver Dam, KY
 5/13/2026 2:58:11 PM

Tech: K. Cardwell
 PC: A. Wells



Structure ID: 952

P3 MH048CN36

ECC CONE w/ 24" HOLE F/G

- P5) 24" - CASTING HEIGHT - 7"
- P4) 24" - GRADE RING F/F - 4"
- P3) 48" - ECC CONE w/ 24" HOLE F/G - 36"
- P2) 48" - MH RISER T/G - 36"
- P1) 48" - MH BASE T/n - 42"
- 1) JOINT WRAP PRIMER - CONSEAL CS-75 (1 gal.)
- 1) JOINT WRAP - 0.065"x6"x50' CONSEAL CS212
- 1) 48" - SAN. INV. CHANNEL - FULL HEIGHT
- 2) 48" - Conseal CS-102 1.00" (Double)
- 2) 24" - Conseal CS-102 1.00" (Double)
- 3) PSX - 12-08 NYLO
- 9) MH Step ML-10-TDS-NCR - 10"

0 lb
 270 lb
 3000 lb
 2515 lb
 4121 lb
 0 lb
 0 lb
 1440 lb
 0 lb
 0 lb
 24 lb
 0 lb

Structure Total: 11369 lb

Structure Notes:
 STATION: 4+44.12 CLUB DR
 1. PER MSD & ASTM C-478 SPECIFICATIONS
 2. CONCRETE: 5,000 PSI AT 28 DAYS
 3. REINFORCEMENT: PER ASTM A615
 4. STEPS REQUIRED
 5. 7" CASTING SUPPLIED BY OTHERS

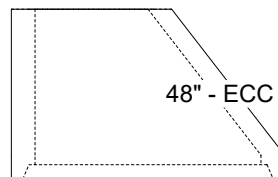
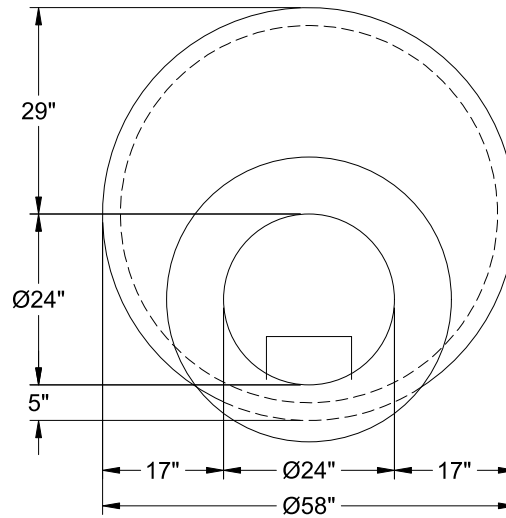

48" - ECC CONE w/ 24" HOLE F/G - 36" - (P3)

Coating (Int):
 Coating (Ext):

Seam Up: Flat
 Seam Dn: Groove

Wall Thickness: 5"

Height (Ext): 36"

Weight (Net): 3000 lb
 Volume (Net): 0.5cu.yd