

Job Name: 25-4508 - Georgetown Commons Target
 Job Location: Georgetown, KY
 Contractor: Winwater Hartford KY Co.

Plant: 100
 5/27/2026 8:36:45 PM

Tech: Jared - F
 PC: A. Chambers



Structure ID: SSMH 2 (3)

P1 MH048BA36

MH BASE T/n

- P4) 24" - CASTING HEIGHT - 7"
- P3) 24" - GRADE RING F/F - 3"
- P2) 48" - ECC CONE w/ 24" HOLE F/G - 42"
- P1) 48" - MH BASE T/n - 36"
- 1) JOINT WRAP - 12" WD x 048" MAC WRAP
- 1) 48" - MH INVERT CHANNEL - FULL HEIGHT
- 1) Inflow Dish FOR MC-375
- 1) CASTING - HOE MC-375 F/C GMWSS
- 1) 48" - Conseal CS-102 1.00" (Double)
- 2) A-Lok - 0285

- 0 lb
- 202 lb
- 3200 lb
- 3782 lb
- 0 lb
- 1440 lb
- 2 lb
- 271 lb
- 0 lb
- 2 lb
-
- Structure Total: 8900 lb

Structure Notes:
 1. PER ASTM C478 SPECIFICATIONS.
 2. CONCRETE = 4,000 PSI AT 28 DAYS.
 3. NO STEPS.
 4. CASTING BY ICAST (HOE MC-375 F/C GMWSS).

 REINFORCING PER ASTM A615 (GRADE 60).
 - CONE (As .12)
 - RISER/WALLS (As .12)
 - FLOOR (As .31) #5 BARS AT 12" C.C.E.W.

Rim: 874' Rim to Invert: 7.2' Slack: 0.4" Sump: 2" Step Position:

Position	Elev	Angle	Ext. (cw)	Pipe	Pipe OD	Connector	Hole	Horz Size	Up ()	Offset
Invert 1	866.8'	0°	0"	8" PVC SDR35	8.5"	A-Lok 0285	9.75"	9.818"	1.125"	0"
Invert 2	866.9'	270°	136.625"	8" PVC SDR35	8.5"	A-Lok 0285	9.75"	9.818"	2.375"	0"
Invert 3										
Invert 4										
Invert 5										
Invert 6										
Invert 7										
Invert 8										

RIGHT-SIDE UP VIEW (int. dimensions)

UPSIDE-DOWN VIEW (int. dimenions)

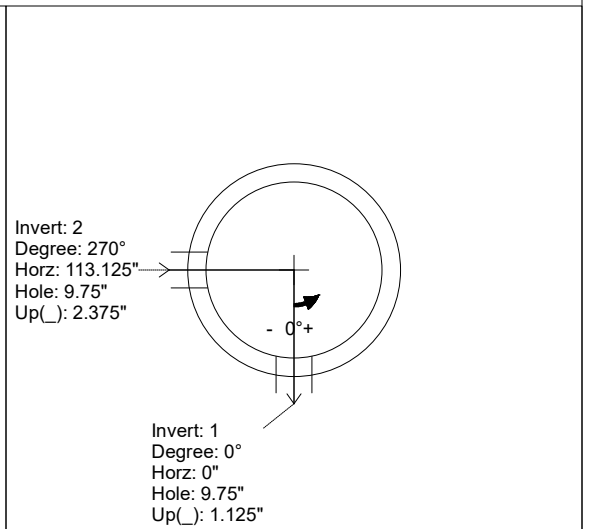
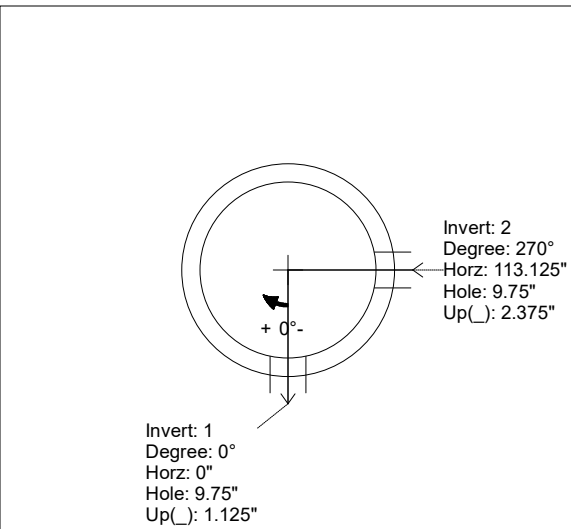
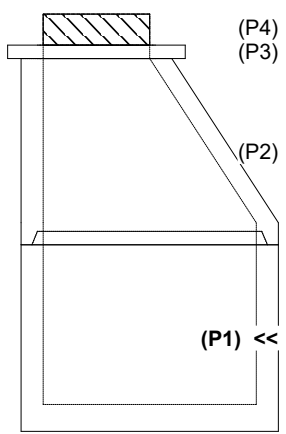

INSIDE WALL DIMENSIONS

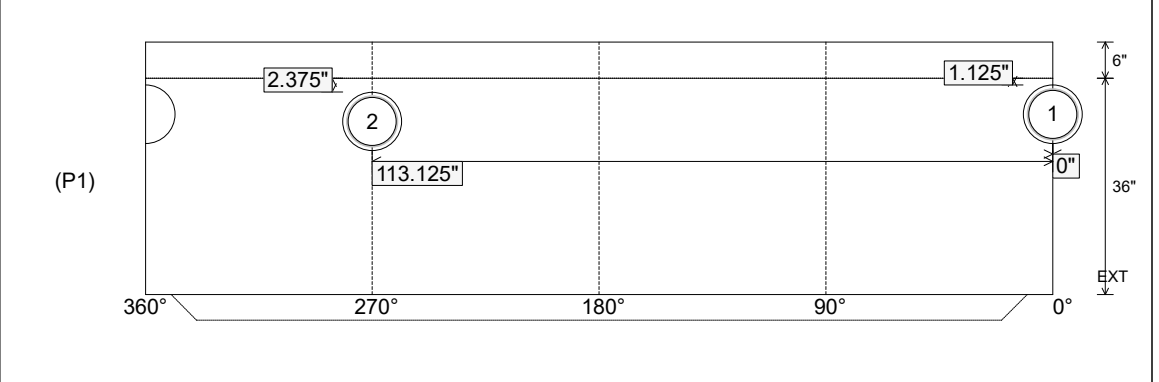

Coating (Int): Coating (Ext):	Seam Up: Tongue Seam Dn: n/a	Wall Thickness: 5" Floor Height: 6"	Height (Int): 36" Height (Ext): 42"	Weight (Net): 3782 lb Volume (Net): 0.97cu.yd
----------------------------------	---------------------------------	--	--	--

Job Name: 25-4508 - Georgetown Commons Target
 Job Location: Georgetown, KY
 Contractor: Winwater Hartford KY Co.

Plant: 100
 5/27/2026 8:36:45 PM

Tech: Jared - F
 PC: A. Chambers



Structure ID: SSMH 2 (3)

P1 MH048BA36

MH BASE T/n

- P4) 24" - CASTING HEIGHT - 7"
- P3) 24" - GRADE RING F/F - 3"
- P2) 48" - ECC CONE w/ 24" HOLE F/G - 42"
- P1) 48" - MH BASE T/n - 36"
- 1) JOINT WRAP - 12" WD x 048" MAC WRAP
- 1) 48" - MH INVERT CHANNEL - FULL HEIGHT
- 1) Inflow Dish FOR MC-375
- 1) CASTING - HOE MC-375 F/C GMWSS
- 1) 48" - Conseal CS-102 1.00" (Double)
- 2) A-Lok - 0285

0 lb
 202 lb
 3200 lb
 3782 lb
 0 lb
 1440 lb
 2 lb
 271 lb
 0 lb
 2 lb

 Structure Total: 8900 lb

- Structure Notes:**
1. PER ASTM C478 SPECIFICATIONS.
 2. CONCRETE = 4,000 PSI AT 28 DAYS.
 3. NO STEPS.
 4. CASTING BY ICAST (HOE MC-375 F/C GMWSS).

REINFORCING PER ASTM A615 (GRADE 60).
 - CONE (As .12)
 - RISER/WALLS (As .12)
 - FLOOR (As .31) #5 BARS AT 12" C.C.E.W.

Rim: 874' Rim to Invert: 7.2' Slack: 0.4" Sump: 2" Step Position:

Position	Elev	Angle	Ext. (cw)	Pipe	Pipe OD	Connector	Hole	Horz Size	Up ()	Offset
Invert 1	866.8'	0°	0"	8" PVC SDR35	8.5"	A-Lok 0285	9.75"	9.818"	1.125"	0"
Invert 2	866.9'	270°	136.625"	8" PVC SDR35	8.5"	A-Lok 0285	9.75"	9.818"	2.375"	0"
Invert 3										
Invert 4										
Invert 5										
Invert 6										
Invert 7										
Invert 8										

RIGHT-SIDE UP VIEW (int. dimensions)

UPSIDE-DOWN VIEW (int. dimenions)

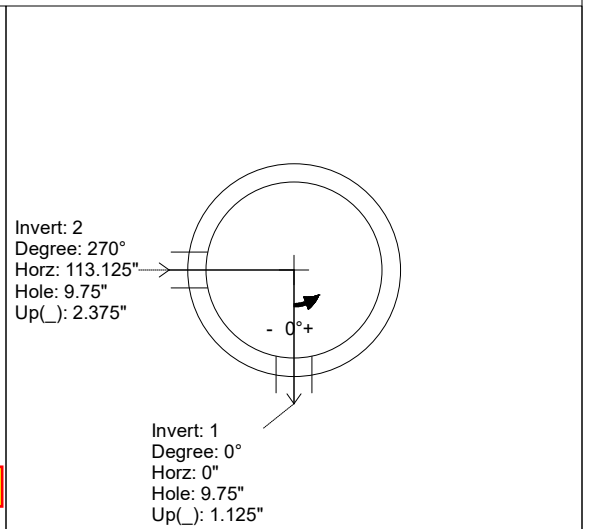
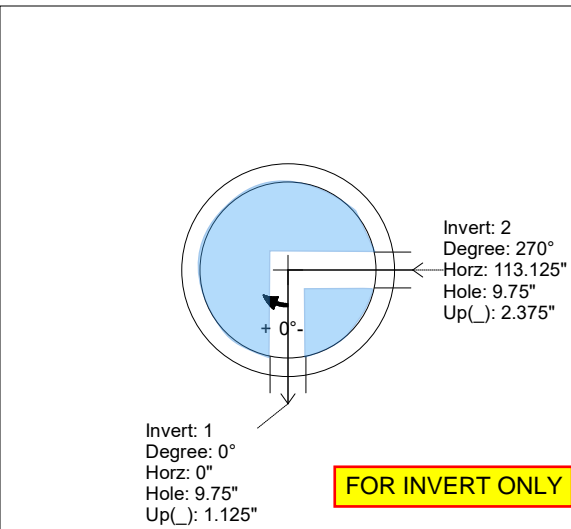
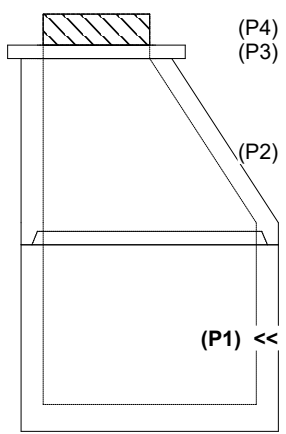

INSIDE WALL DIMENSIONS

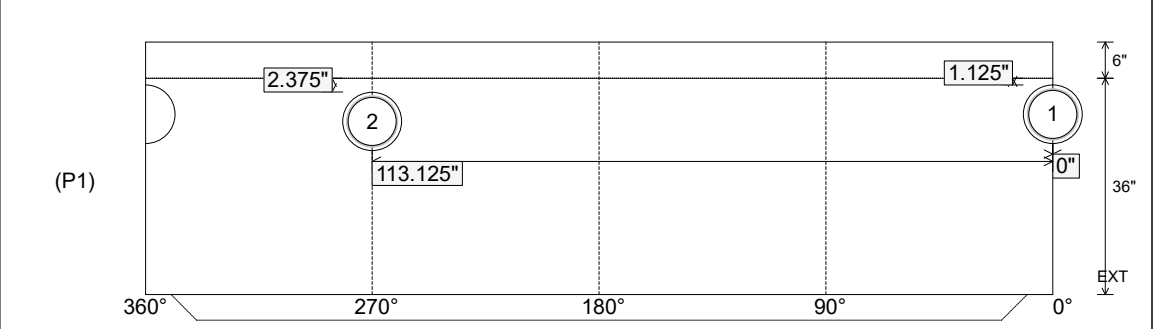

Coating (Int): Coating (Ext):	Seam Up: Tongue Seam Dn: n/a	Wall Thickness: 5" Floor Height: 6"	Height (Int): 36" Height (Ext): 42"	Weight (Net): 3782 lb Volume (Net): 0.97cu.yd
----------------------------------	---------------------------------	--	--	--