

Job Name: 25-4508 - Georgetown Commons Target
 Job Location: Georgetown, KY
 Contractor: Winwater Hartford KY Co.

Plant: 100
 5/28/2026 11:25:29 AM

Tech: Jared - F
 PC: A. Chambers



Structure ID: 5 (8)

P1 MH048BA36

MH BASE T/n

- P3) 24" x 36" - CASTING HEIGHT - 6"
- P2) 48" - MH FLAT TOP w/24"x36" Hole F/G - 12"
- P1) 48" - MH BASE T/n - 36"
- 1) CASTING - HOE 470 SET LV (F/G/H)
- 1) 48" - Conseal CS-102 1.00"
- 1) 24" x 36" - Conseal CS-102 1.00"
- 1) Hole - 30
- 1) Hole - 24

0 lb
 1300 lb
 3332 lb
 394 lb
 0 lb
 0 lb
 0 lb
 0 lb
 0 lb
 Structure Total: 5026 lb

Structure Notes:
 1. PER ASTM C478 SPECIFICATIONS.
 2. CONCRETE = 4,000 PSI AT 28 DAYS.
 3. NO STEPS AND NO INVERT CHANNEL.
 4. CASTING BY ICAST (HOE 470 SET LV (F/G/H)).

REINFORCING PER ASTM A615 (GRADE 60).
 - TOP SLAB (As .62) #5 BARS AT 6" C.C.E.W..
 - RISER/WALLS (As .12)
 - FLOOR (As .31) #5 BARS AT 12" C.C.E.W.

Rim: 871' Rim to Invert: 4.35' Slack: 0.1" Sump: 1.9" Step Position:

Position	Elev	Angle	Ext. (cw)	Pipe	Pipe OD	Connector	Hole	Horz Size	Up ()	Offset
Invert 1	866.65'	0°	0"	24" HDPE	27.8"	Hole 30	30"	32.406"	0"	0"
Invert 2	866.65'	180°	91.125"	18" HDPE	21.2"	Hole 24	24"	25.133"	0.25"	0"
Invert 3										
Invert 4										
Invert 5										
Invert 6										
Invert 7										
Invert 8										

RIGHT-SIDE UP VIEW (int. dimensions)

UPSIDE-DOWN VIEW (int. dimensions)

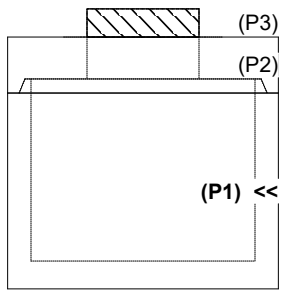
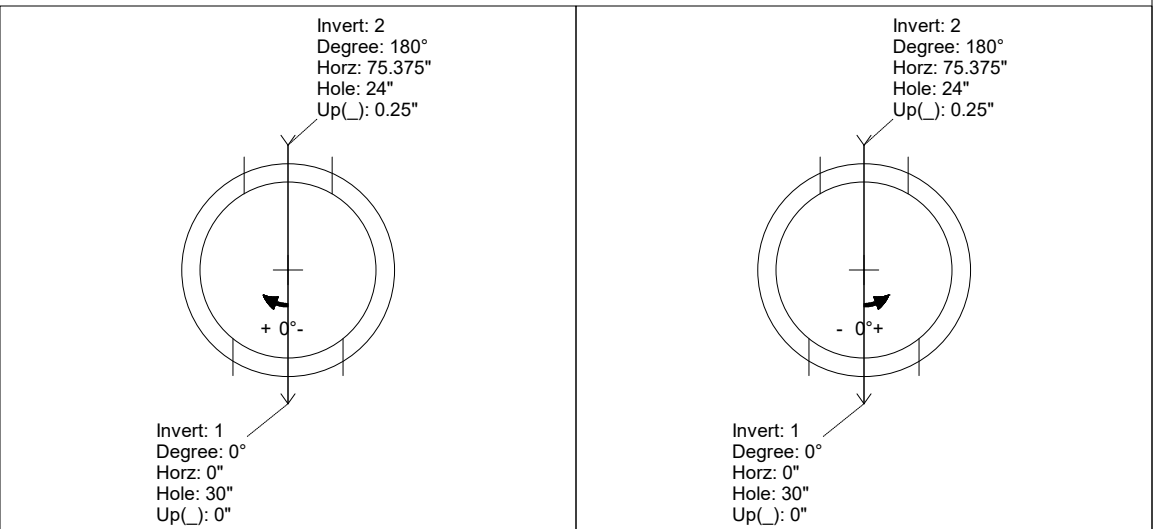

INSIDE WALL DIMENSIONS

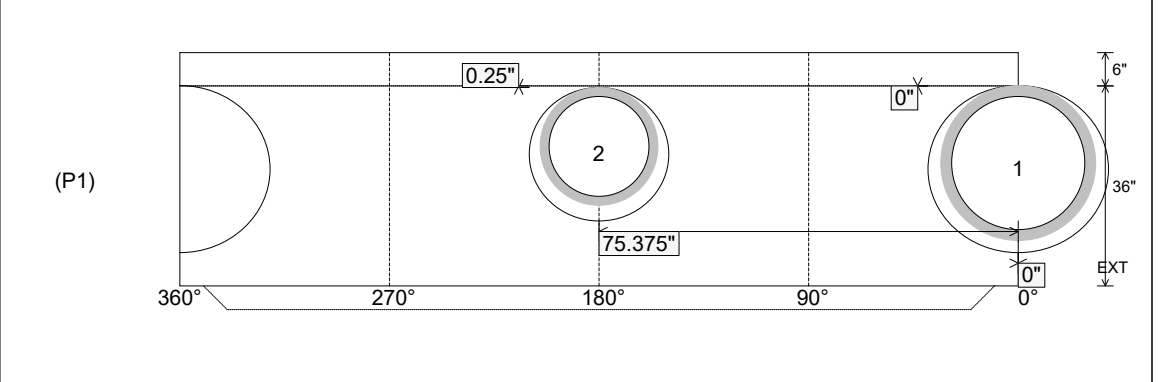

Coating (Int): Coating (Ext):	Seam Up: Tongue Seam Dn: n/a	Wall Thickness: 5" Floor Height: 6"	Height (Int): 36" Height (Ext): 42"	Weight (Net): 3332 lb Volume (Net): 0.85cu.yd
----------------------------------	---------------------------------	--	--	--