

Job Name: 25-4508 - Georgetown Commons Target
 Job Location: Georgetown, KY
 Contractor: Winwater Hartford KY Co.

Plant: 100
 5/28/2026 11:25:39 AM

Tech: Jared - F
 PC: A. Chambers



Structure ID: 105 (27)

P1 MH048BAVF

MH BASE Custom Ht T/n

- P3) 24" - CASTING HEIGHT - 7"
- P2) 48" - MH FLAT TOP w/ 24" ECC Hole F/G - 12"
- P1) 48" - MH BASE Custom Ht T/n - 69"
- 1) CASTING - HOE MC-375 F/C Storm
- 1) 48" - Conseal CS-102 1.00"
- 2) Hole - 30
- 1) Hole - 16
- 6) MH Step ML-10-TDS-NCR - 10"

0 lb
 1561 lb
 5433 lb
 271 lb
 0 lb
 0 lb
 0 lb
 0 lb
 0 lb
 Structure Total: 7265 lb

Structure Notes:
 1. PER ASTM C478 SPECIFICATIONS.
 2. CONCRETE = 4,000 PSI AT 28 DAYS.
 3. NO INVERT CHANNEL.
 4. CASTING BY ICAST (HOE MC-375 F/C STORM).
 REINFORCING PER ASTM A615 (GRADE 60).
 - TOP SLAB (As .62) #5 BARS AT 6" C.C.E.W..
 - RISER/WALLS (As .12)
 - FLOOR (As .31) #5 BARS AT 12" C.C.E.W.

Rim: 873.2' Rim to Invert: 7.2' Slack: 0.3" Sump: 1.9" Step Position: 270

Position	Elev	Angle	Ext. (cw)	Pipe	Pipe OD	Connector	Hole	Horz Size	Up ()	Offset
Invert 1	866'	0°	0"	24" HDPE	27.8"	Hole 30	30"	32.406"	0"	0"
Invert 2	867.65'	75°	38"	12" HDPE	14.5"	Hole 16	16"	16.312"	20.5"	0"
Invert 3	867.65'	167°	84.5"	24" HDPE	27.8"	Hole 30	30"	32.406"	19.75"	0"
Invert 4										
Invert 5										
Invert 6										
Invert 7										
Invert 8										

RIGHT-SIDE UP VIEW (int. dimensions)

UPSIDE-DOWN VIEW (int. dimensions)

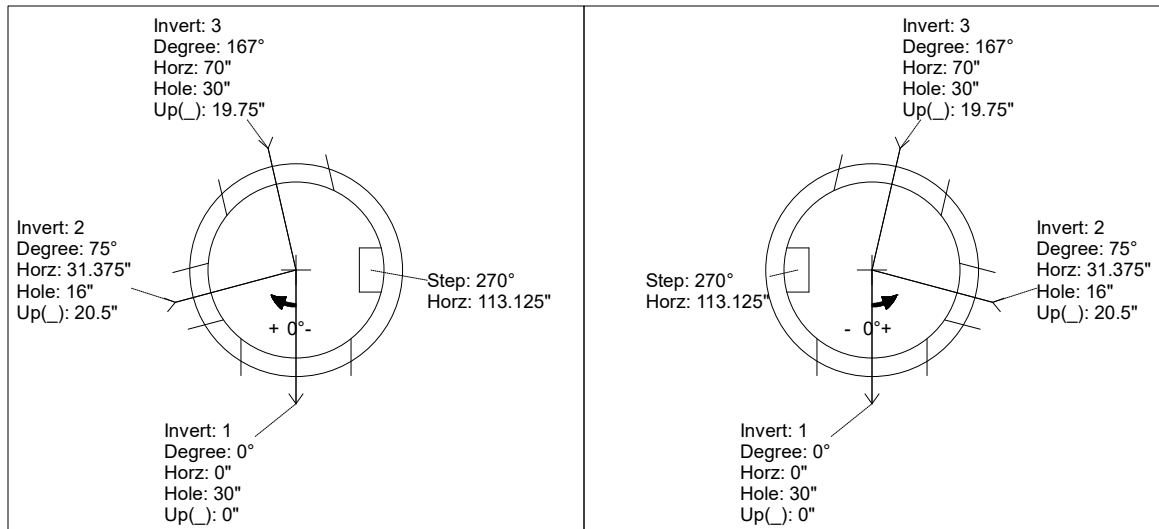

INSIDE WALL DIMENSIONS

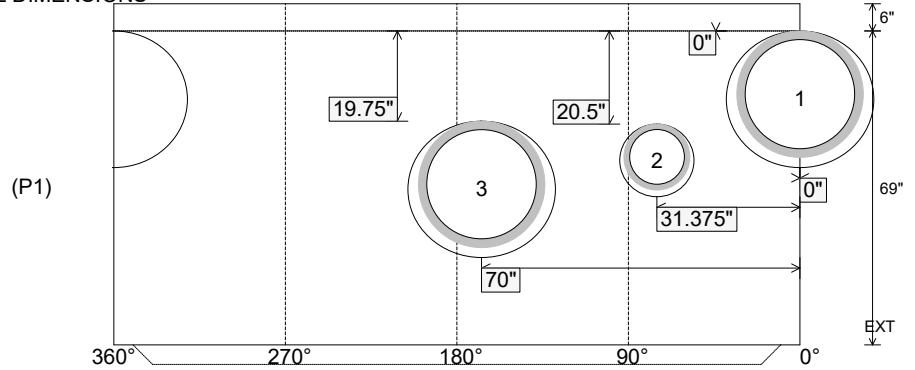

Coating (Int): Coating (Ext):	Seam Up: Tongue Seam Dn: n/a	Wall Thickness: 5" Floor Height: 6"	Height (Int): 69" Height (Ext): 75"	Weight (Net): 5433 lb Volume (Net): 1.39cu.yd
----------------------------------	---------------------------------	--	--	--