

Job Name: 25-2422 - Woodland Springs Section 3 (Sanitary)  
 Job Location: Clarksville, TN  
 Contractor: Byard Construction, LLC

Plant: 100

5/14/2026 2:16:06 PM

Tech: Jared - A

PC: A. Chambers



**Structure ID: A-10**

**P1 MH048BA30CDARED**

**MH BASE w/ConBlock-CDA Red T/n**

P4) 24" - CASTING HEIGHT - 6"	0 lb
P3) 48" - ECC CONE w/ 24" HOLE, w/ConBlock-CDA Red F/G - 30"	1961 lb
P2) 48" - MH RISER w/ConBlock-CDA Red T/G - 24"	1677 lb
P1) 48" - MH BASE w/ConBlock-CDA Red T/n - 30"	3336 lb
1) 48" - MH INVERT CHANNEL w/ConBlock-CDA Red - FULL HEIGHT	1440 lb
1) JOINT WRAP - 0.065"x6"x50' CONSEAL CS212	0 lb
1) JOINT WRAP PRIMER - CONSEAL CS-75 (1 gal.)	0 lb
1) ADMIXTURE CONBLOCK CDA RED	0 lb
1) CASTING - JBS 1155 F/C SANITARY	250 lb
2) 48" - Conseal CS-102 1.00" (Double)	0 lb
1) 24" - Conseal CS-102 1.00" (Double)	0 lb
1) PSX - 12-08 NYLO	8 lb
2) PSX - 8QRS-S NYLO	13 lb
7) MH Step ML-10-TDS-NCR - 10"	0 lb
<b>Structure Total:</b>	<b>8685 lb</b>

- Structure Notes:**
1. PER ASTM C-478 SPECIFICATIONS
  2. CONCRETE: 4,000 PSI AT 28 DAYS
  3. REINFORCEMENT: PER ASTM A615
  4. INVERT CHANNEL REQUIRED
  5. CONBLOCK CDA RED ADMIXTURE REQUIRED
  6. STEPS AT 180 DEGREES
  7. JBS 1155 FRAME & COVER "SANITARY" SUPPLIED BY ICAST

Rim: 469.8' Rim to Invert: 7.35' Slack: 0.2" Sump: 2" Step Position: 180°

Position	Elev	Angle	Ext. (cw)	Pipe	Pipe OD	Connector	Hole	Horz Size	Up ( )	Offset
Invert 1	462.45'	0°	0"	8" PVC SDR26	8.5"	PSX 12-08 NYLO	12"	12.129"	0"	0"
Invert 2	462.65'	115°	58.25"	4" PVC SDR35	4.25"	PSX 8QRS-S NYLO	8"	8.038"	2.375"	0"
Invert 3	462.65'	245°	124"	4" PVC SDR35	4.25"	PSX 8QRS-S NYLO	8"	8.038"	2.375"	0"
Invert 4										
Invert 5										
Invert 6										
Invert 7										
Invert 8										

RIGHT-SIDE UP VIEW (int. dimensions)

UPSIDE-DOWN VIEW (int. dimensions)

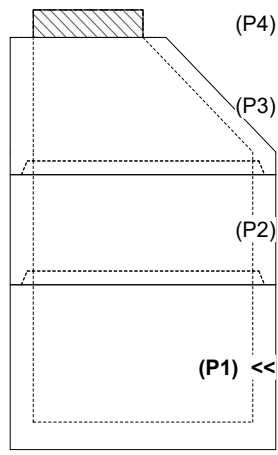
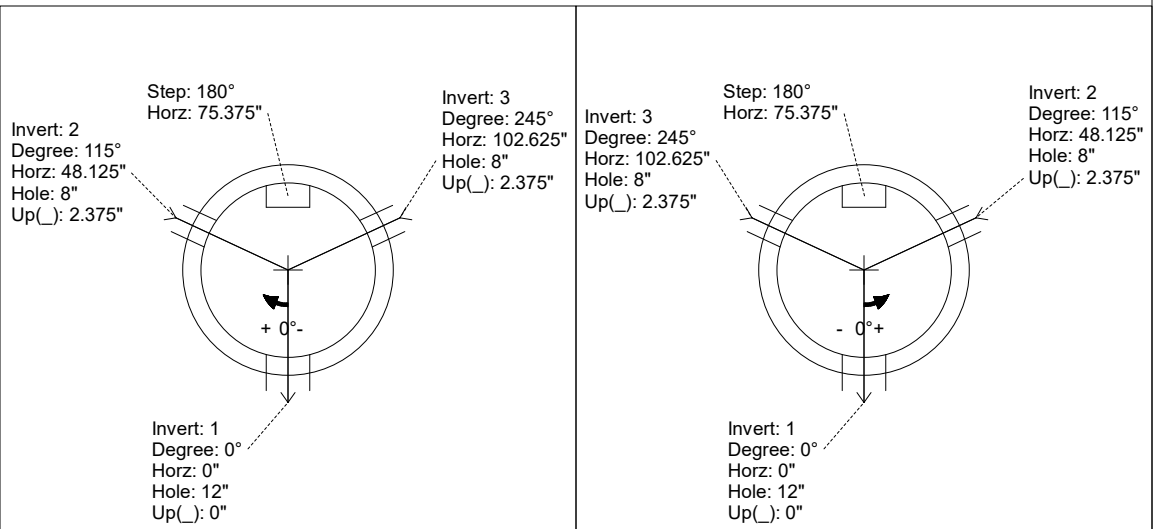

INSIDE WALL DIMENSIONS

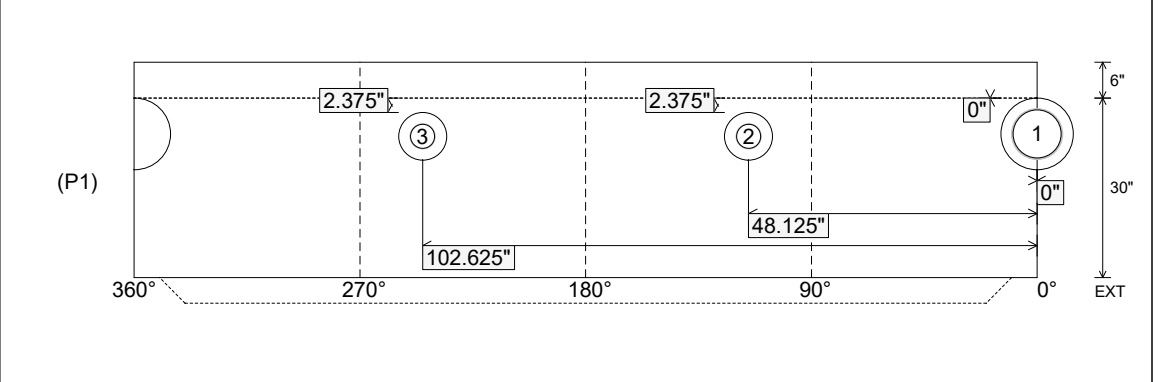

Coating (Int): Coating (Ext):	Seam Up: Tongue Seam Dn: n/a	Wall Thickness: 5" Floor Height: 6"	Height (Int): 30" Height (Ext): 36"	Weight (Net): 3336 lb Volume (Net): 0.85cu.yd
----------------------------------	---------------------------------	--	--	--

**Structure ID: A-10**

**P1 MH048BA30CDARED**

**MH BASE w/ConBlock-CDA Red T/n**

P4) 24" - CASTING HEIGHT - 6" P3) 48" - ECC CONE w/ 24" HOLE, w/ConBlock-CDA Red F/G - 30" P2) 48" - MH RISER w/ConBlock-CDA Red T/G - 24" P1) 48" - MH BASE w/ConBlock-CDA Red T/n - 30" 1) 48" - MH INVERT CHANNEL w/ConBlock-CDA Red - FULL HEIGHT 1) JOINT WRAP - 0.065"x6"x50' CONSEAL CS212 1) JOINT WRAP PRIMER - CONSEAL CS-75 (1 gal.) 1) ADMIXTURE CONBLOCK CDA RED 1) CASTING - JBS 1155 F/C SANITARY 2) 48" - Conseal CS-102 1.00" (Double) 1) 24" - Conseal CS-102 1.00" (Double) 1) PSX - 12-08 NYLO 2) PSX - 8QRS-S NYLO 7) MH Step ML-10-TDS-NCR - 10"	0 lb 1961 lb 1677 lb 3336 lb 1440 lb 0 lb 0 lb 0 lb 250 lb 0 lb 0 lb 8 lb 13 lb 0 lb
<b>Structure Total:</b>	<b>8685 lb</b>

- Structure Notes:**
1. PER ASTM C-478 SPECIFICATIONS
  2. CONCRETE: 4,000 PSI AT 28 DAYS
  3. REINFORCEMENT: PER ASTM A615
  4. INVERT CHANNEL REQUIRED
  5. CONBLOCK CDA RED ADMIXTURE REQUIRED
  6. STEPS AT 180 DEGREES
  7. JBS 1155 FRAME & COVER "SANITARY" SUPPLIED BY ICAST

Rim: 469.8'    Rim to Invert: 7.35'    Slack: 0.2"    Sump: 2"    Step Position: 180°

Position	Elev	Angle	Ext. (cw)	Pipe	Pipe OD	Connector	Hole	Horz Size	Up ( )	Offset
Invert 1	462.45'	0°	0"	8" PVC SDR26	8.5"	PSX 12-08 NYLO	12"	12.129"	0"	0"
Invert 2	462.65'	115°	58.25"	4" PVC SDR35	4.25"	PSX 8QRS-S NYLO	8"	8.038"	2.375"	0"
Invert 3	462.65'	245°	124"	4" PVC SDR35	4.25"	PSX 8QRS-S NYLO	8"	8.038"	2.375"	0"
Invert 4										
Invert 5										
Invert 6										
Invert 7										
Invert 8										

RIGHT-SIDE UP VIEW (int. dimensions)

UPSIDE-DOWN VIEW (int. dimensions)

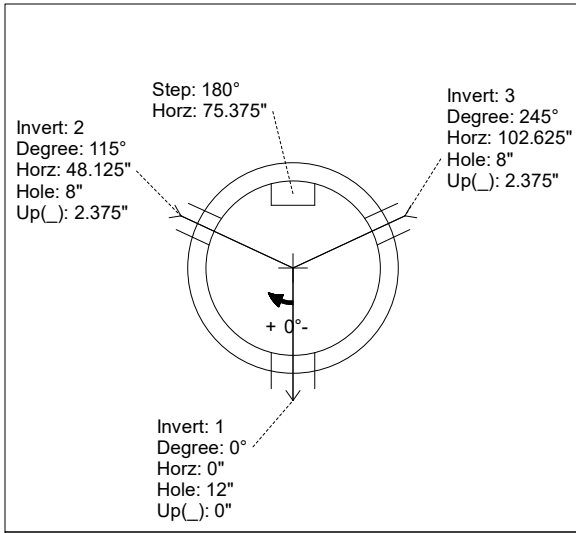
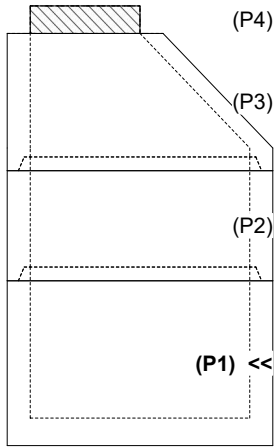

INVERT CHANNEL DRAWING

INSIDE WALL DIMENSIONS

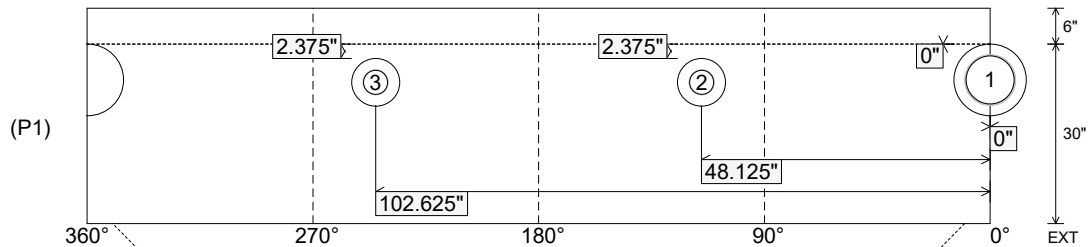

Coating (Int): Coating (Ext):	Seam Up: Tongue Seam Dn: n/a	Wall Thickness: 5" Floor Height: 6"	Height (Int): 30" Height (Ext): 36"	Weight (Net): 3336 lb Volume (Net): 0.85cu.yd
----------------------------------	---------------------------------	--	--	--