

Job Name: 26-1694 1212 Baptist World Center Dr
 Job Location: Nashville, TN
 Contractor: Hayes Pipe Supply

Plant: Beaver Dam
 5/19/2026 11:49:25 AM

Tech: S. Felletter
 PC: E. Bradley



Structure ID: MH-A0-2 SS-MH

P1 MH048BA24CDARED

MH BASE w/ConBlock-CDA Red T/n

- P4) 24" - CASTING HEIGHT - 7"
- P3) 48" - CON CONE w/24" HOLE, w/ConBlock-CDA Red F/G - 36"
- P2) 48" - MH RISER w/ConBlock-CDA Red T/G - 24"
- P1) 48" - MH BASE w/ConBlock-CDA Red T/n - 24"
- 1) 48" - MH INVERT CHANNEL w/ConBlock-CDA Red - FULL HEIGHT
- 1) JOINT WRAP - 0.065"x6"x50' CONSEAL CS212
- 1) JOINT WRAP PRIMER - CONSEAL CS-75 (1 gal.)
- 1) CASTING - JBS 1150 F/C SANITARY
- 2) 48" - Conseal CS-102 1.00" (Double)
- 1) PSX - 12-08 NYLO
- 7) MH Step ML-10-TDS-NCR - 10"

0 lb
 2251 lb
 1677 lb
 2959 lb
 1440 lb
 0 lb
 0 lb
 250 lb
 0 lb
 8 lb
 0 lb

 Structure Total: 8585 lb

Structure Notes:
 1. PER ASTM C478 SPECIFICATIONS.
 2. CONCRETE = 4,000 PSI AT 28 DAYS.
 3. ADMIXTURE = CONBLOCK CDA RED.
 4. CASTING BY ICAST (JBS 1150 F/C "SANITARY").

REINFORCING PER ASTM A615 (GRADE 60).
 - CONE (As .12)
 - RISER/WALLS (As .12)
 - FLOOR (As .31) #5 BARS AT 12" C.C.E.W.

Rim: 422.03' Rim to Invert: 7.63' Slack: 2.56" Sump: 2" Step Position: 180

Position	Elev	Angle	Ext. (cw)	Pipe	Pipe OD	Connector	Hole	Horz Size	Up ()	Offset
Invert 1	414.4'	0°	0"	8" PVC SDR35	8.5"	PSX 12-08 NYLO	12"	12.129"	0"	0"
Invert 2										
Invert 3										
Invert 4										
Invert 5										
Invert 6										
Invert 7										
Invert 8										

RIGHT-SIDE UP VIEW (int. dimensions)

UPSIDE-DOWN VIEW (int. dimensions)

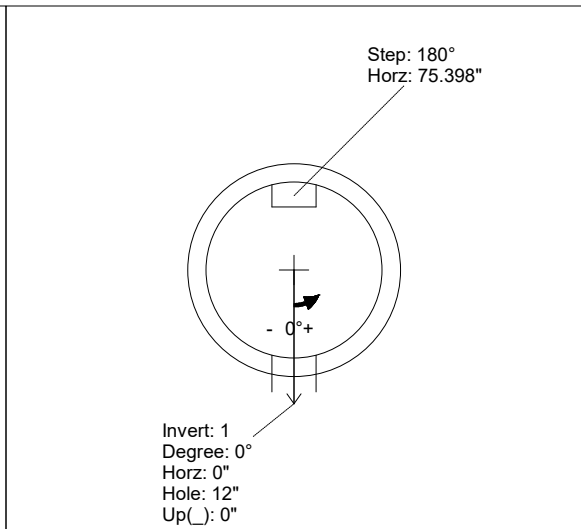
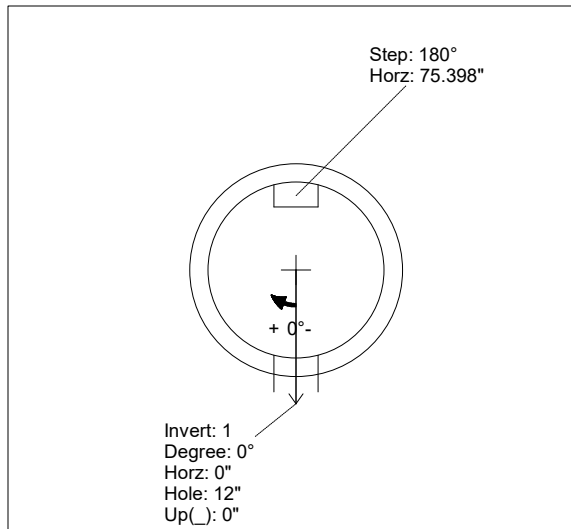
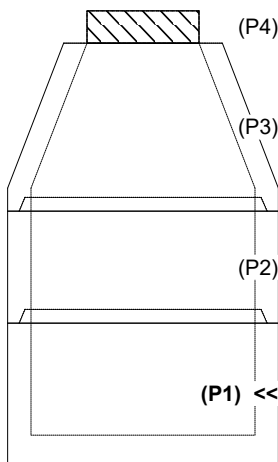

INSIDE WALL DIMENSIONS

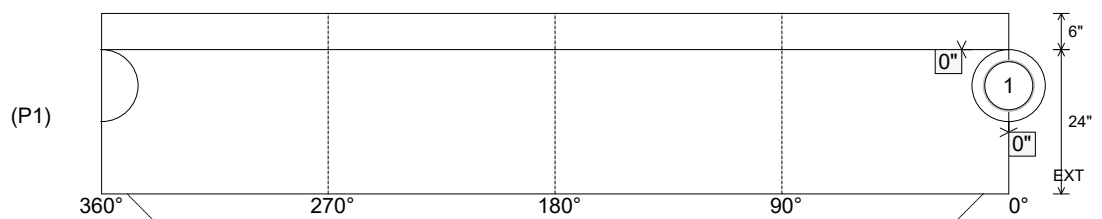

Coating (Int):
 Coating (Ext):

Seam Up: Tongue
 Seam Dn: n/a

Wall Thickness: 5"
 Floor Height: 6"

Height (Int): 24"
 Height (Ext): 30"

Weight (Net): 2959 lb
 Volume (Net): 0.76cu.yd

Job Name: 26-1694 1212 Baptist World Center Dr
 Job Location: Nashville, TN
 Contractor: Hayes Pipe Supply

Plant: Beaver Dam
 5/19/2026 11:49:25 AM

Tech: S. Felletter
 PC: E. Bradley



Structure ID: MH-A0-2 SS-MH

P1 MH048BA24CDARED

MH BASE w/ConBlock-CDA Red T/n

- P4) 24" - CASTING HEIGHT - 7"
- P3) 48" - CON CONE w/24" HOLE, w/ConBlock-CDA Red F/G - 36"
- P2) 48" - MH RISER w/ConBlock-CDA Red T/G - 24"
- P1) 48" - MH BASE w/ConBlock-CDA Red T/n - 24"
- 1) 48" - MH INVERT CHANNEL w/ConBlock-CDA Red - FULL HEIGHT
- 1) JOINT WRAP - 0.065"x6"x50' CONSEAL CS212
- 1) JOINT WRAP PRIMER - CONSEAL CS-75 (1 gal.)
- 1) CASTING - JBS 1150 F/C SANITARY
- 2) 48" - Conseal CS-102 1.00" (Double)
- 1) PSX - 12-08 NYLO
- 7) MH Step ML-10-TDS-NCR - 10"

0 lb
 2251 lb
 1677 lb
 2959 lb
 1440 lb
 0 lb
 0 lb
 250 lb
 0 lb
 8 lb
 0 lb

 Structure Total: 8585 lb

- Structure Notes:**
1. PER ASTM C478 SPECIFICATIONS.
 2. CONCRETE = 4,000 PSI AT 28 DAYS.
 3. ADMIXTURE = CONBLOCK CDA RED.
 4. CASTING BY ICAST (JBS 1150 F/C "SANITARY").

REINFORCING PER ASTM A615 (GRADE 60).
 - CONE (As .12)
 - RISER/WALLS (As .12)
 - FLOOR (As .31) #5 BARS AT 12" C.C.E.W.

Invert channel drawing
 Full height invert

Structure Total: 8585 lb

Rim: 422.03' Rim to Invert: 7.63' Slack: 2.56" Sump: 2" Step Position: 180

Position	Elev	Angle	Ext. (cw)	Pipe	Pipe OD	Connector	Hole	Horz Size	Up ()	Offset
Invert 1	414.4'	0°	0"	8" PVC SDR35	8.5"	PSX 12-08 NYLO	12"	12.129"	0"	0"
Invert 2										
Invert 3										
Invert 4										
Invert 5										
Invert 6										
Invert 7										
Invert 8										

RIGHT-SIDE UP VIEW (int. dimensions)

UPSIDE-DOWN VIEW (int. dimensions)

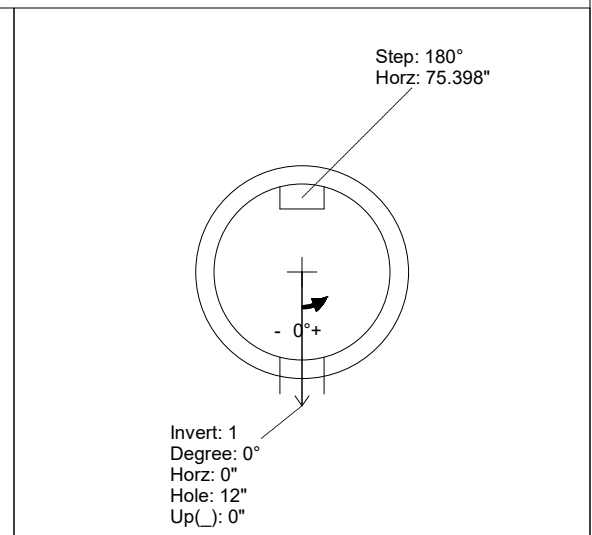
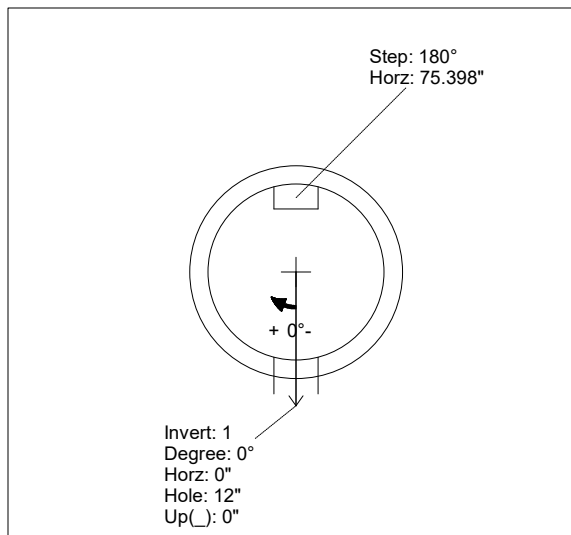
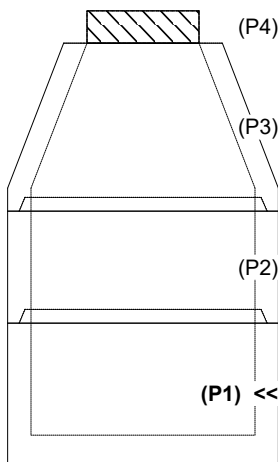

INSIDE WALL DIMENSIONS

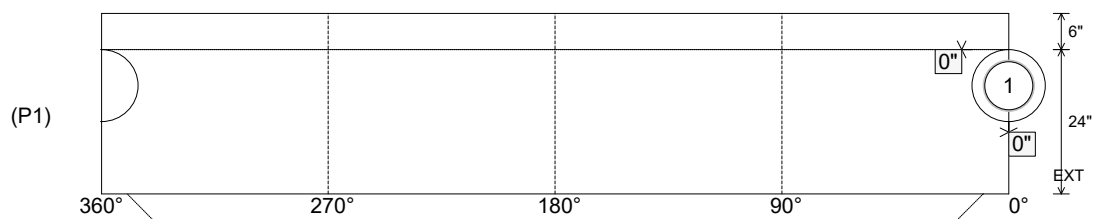

Coating (Int):
 Coating (Ext):

Seam Up: Tongue
 Seam Dn: n/a

Wall Thickness: 5"
 Floor Height: 6"

Height (Int): 24"
 Height (Ext): 30"

Weight (Net): 2959 lb
 Volume (Net): 0.76cu.yd