

Job Name: 25-2511B - Blue Sky Sec 1 (Storm)	Plant: 100	Tech: J. Horsley - F
Job Location: Clarksville, TN	11/17/2025 5:02:12 PM	PC: A. Chambers
Contractor: Byard Construction, LLC		

Structure ID: AG

P1 MH048BAVF

MH BASE Custom Ht F/n

P3) 24" x 36" - CASTING HEIGHT - 6"	0 lb
P2) 48" - MH FLAT TOP w/24"x36" Hole F/F - 7"	1044 lb
P1) 48" - MH BASE Custom Ht F/n - 38"	3353 lb
1) Conseal CS-102 1.00" (Single)	0 lb
1) CASTING - JBS 3080-V SET (F/G/H)	500 lb
2) Hole - 30	0 lb
Structure Total:	4897 lb

- Structure Notes:**
- PER ASTM C478 SPECIFICATIONS.
 - CONCRETE = 4,000 PSI AT 28 DAYS.
 - NO STEPS AND NO INVERT CHANNEL.
 - CASTING BY I-CAST (JBS 3080-V SET F/G/H).

- REINFORCING PER ASTM A615 (GRADE 60).**
- TOP SLAB (As .62) #5 BARS AT 6" C.C.E.W..
 - RISER/WALLS (As .12)
 - FLOOR (As .31) #5 BARS AT 12" C.C.E.W.

Rim: 504.12' Rim to Invert: 4.12' Slack: 0.34" Sump: 1.9" Step Position:

Position	Elev	Angle	Ext. (cw)	Pipe	Pipe OD	Connector	Hole	Horz Size	Up ()	Offset
Invert 1	500'	0°	0"	24" HDPE	27.8"	Hole 30	30"	32.406"	0"	0"
Invert 2	500.1'	237°	120"	24" HDPE	27.8"	Hole 30	30"	32.406"	1.25"	0"
Invert 3										
Invert 4										
Invert 5										
Invert 6										
Invert 7										
Invert 8										

RIGHT-SIDE UP VIEW (int. dimensions)

UPSIDE-DOWN VIEW (int. dimensions)

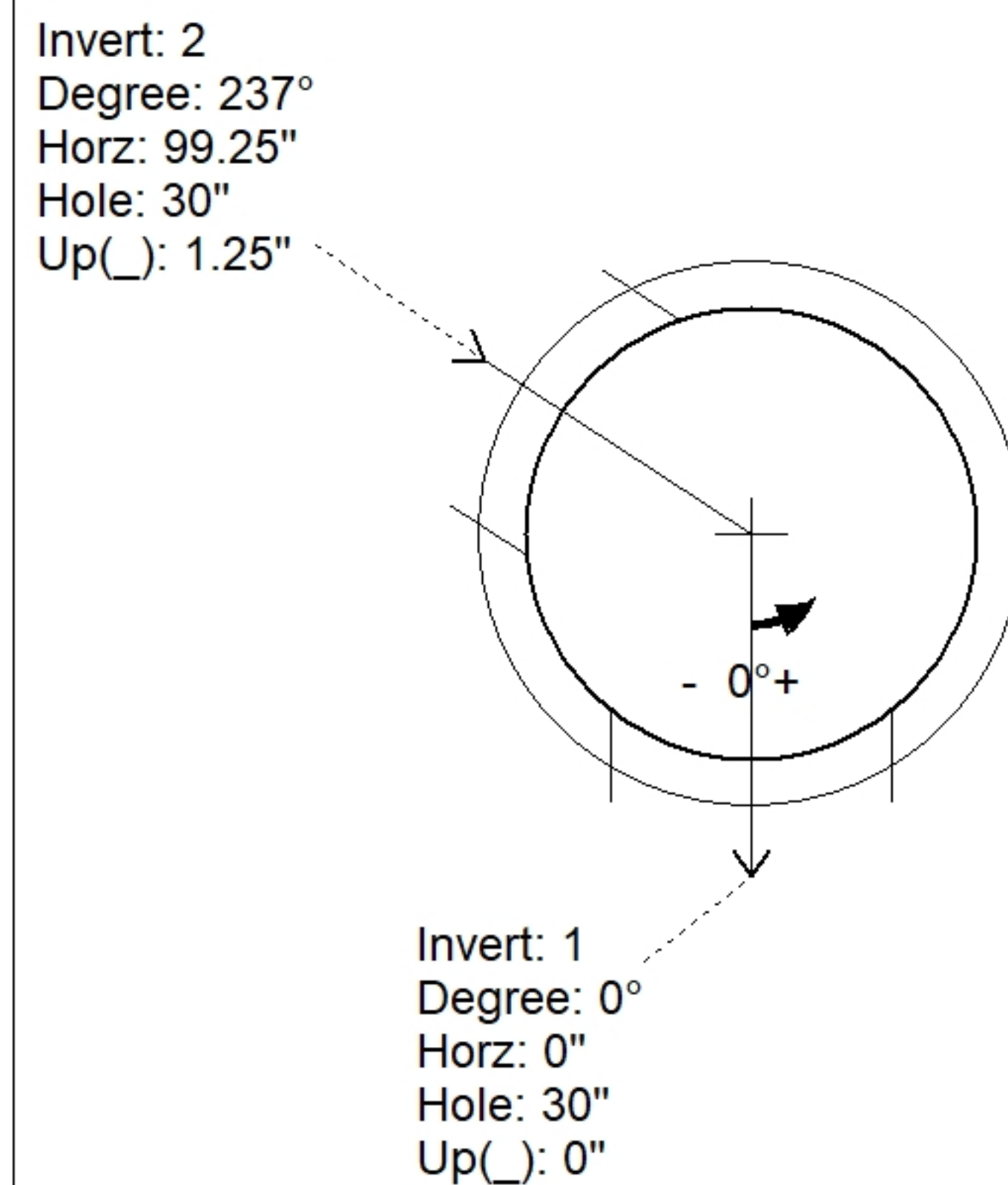
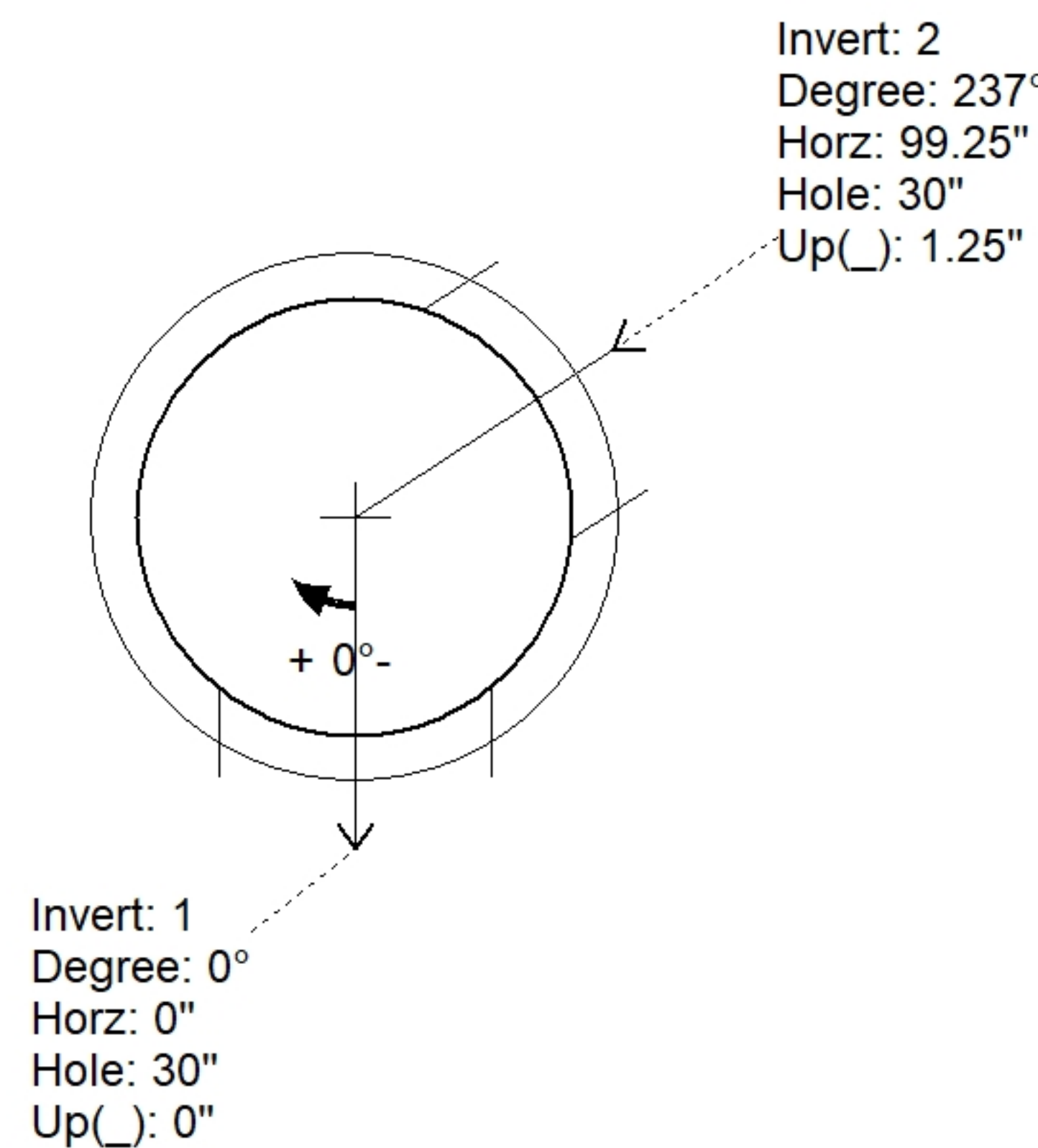
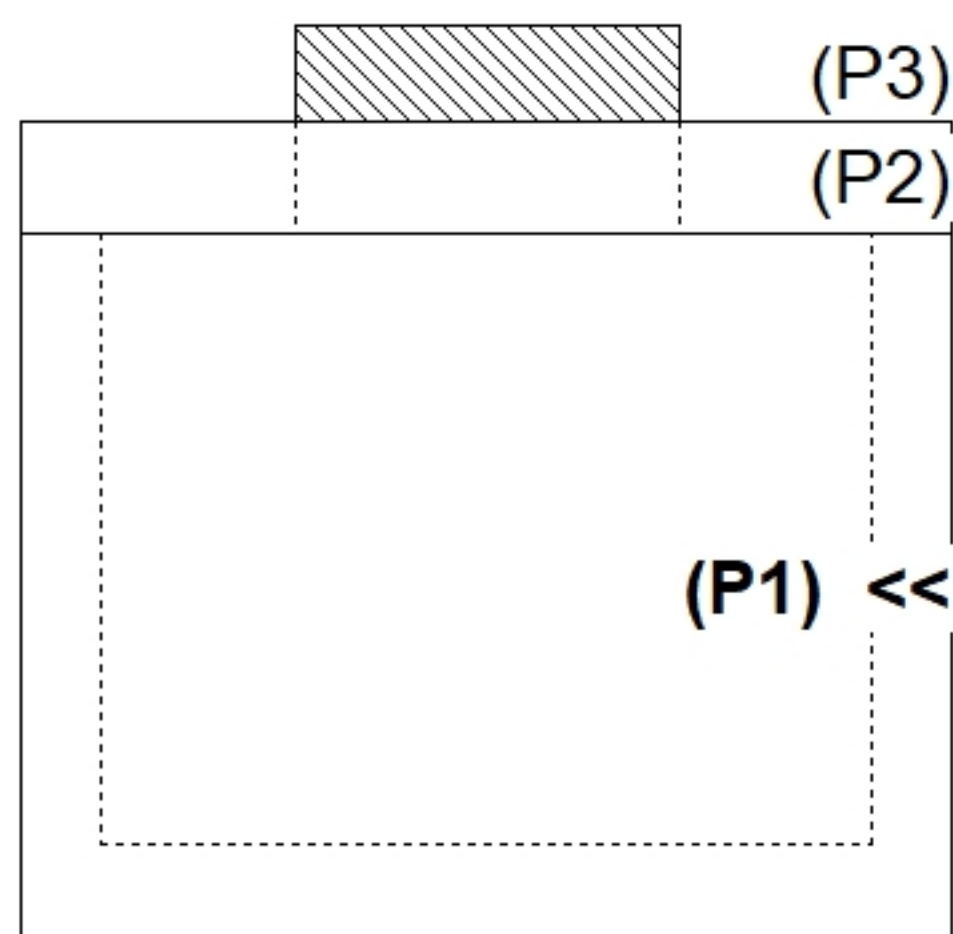

INSIDE WALL DIMENSIONS

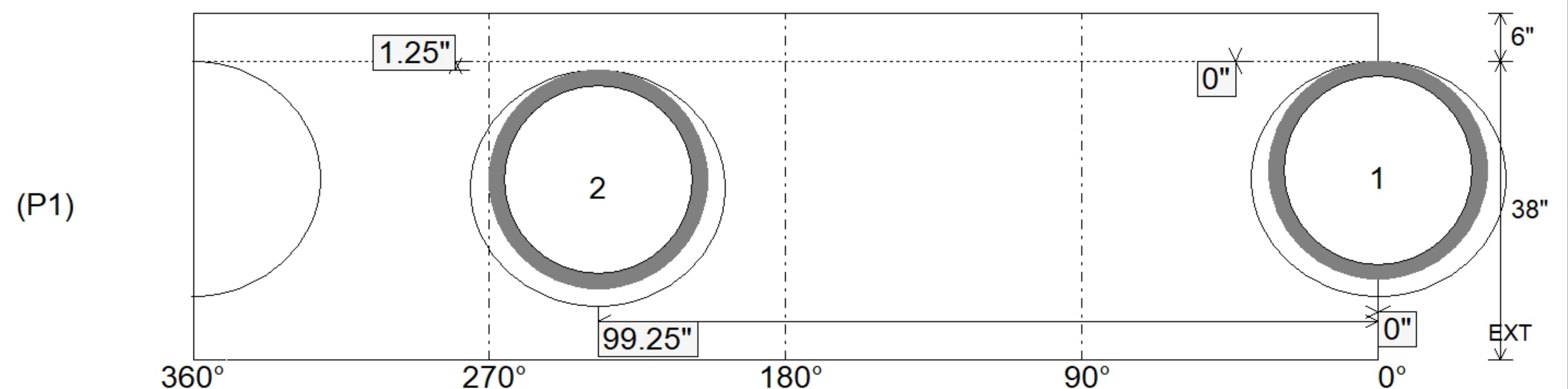

Coating (Int):	Seam Up: Flat	Wall Thickness: 5"	Height (Int): 38"	Weight (Net): 3353 lb
Coating (Ext):	Seam Dn: n/a	Floor Height: 6"	Height (Ext): 44"	Volume (Net): 0.86cu.yd