

Job Name: 26-1227 - Project Colt
 Job Location: Evansville, IN
 Contractor: Russell's Excavating

Plant: 100
 5/12/2026 11:30:15 AM

Tech: Jared - F
 PC: A. Chambers



Structure ID: 302-7 MHC

P1 MH048BAVF

MH BASE Custom Ht F/n

- P3) 24" x 36" - CASTING HEIGHT - 4"
- P2) 48" - MH FLAT TOP w/24"x36" Hole F/F - 7"
- P1) 48" - MH BASE Custom Ht F/n - 69"
- 1) CASTING - HOE 518 F/G
- 1) 48" - Conseal CS-102 1.00"
- 1) 24" x 36" - Conseal CS-102 1.00"
- 2) Hole - 24
- 1) Hole - 16
- 2) Hole - 6
- 6) MH Step ML-10-TDS-NCR - 10"

0 lb
 1044 lb
 5646 lb
 354 lb
 0 lb
 0 lb
 0 lb
 0 lb
 0 lb
 0 lb
 0 lb
 0 lb
 7045 lb

Structure Total: 7045 lb

Structure Notes:

1. INDOT MH TYPE C / ASTM C478 SPEC'S.
2. CONCRETE = 4,000 PSI AT 28 DAYS.
3. NO INVERT CHANNEL.
4. CASTING BY ICAST (HOE 518 F/G).

REINFORCING PER ASTM A615 (GRADE 60).
 - TOP SLAB (As .62) #5 BARS AT 6" C.C.E.W..
 - RISER/WALLS (As .12)
 - FLOOR (As .62) #5 BARS AT 6" C.C.E.W.

Rim: 381.59' Rim to Invert: 6.59' Slack: 0.705" Sump: 1.625" Step Position: 270°

Position	Elev	Angle	Ext. (cw)	Pipe	Pipe OD	Connector	Hole	Horz Size	Up ()	Offset
Invert 1	375'	0°	0"	18" HDPE	21.2"	Hole 24	24"	25.133"	0"	0"
Invert 2	375'	192°	97.125"	18" HDPE	21.2"	Hole 24	24"	25.133"	0"	0"
Invert 3	378'	118°	59.75"	12" HDPE	14.5"	Hole 16	16"	16.312"	36.375"	0"
Invert 4	379.55'	30°	15.125"	4" HDPE (perf pipe)	4.8"	Hole 6	6"	6.016"	55.875"	0"
Invert 5	379.55'	140°	70.875"	4" HDPE (perf pipe)	4.8"	Hole 6	6"	6.016"	55.875"	0"
Invert 6										
Invert 7										
Invert 8										

RIGHT-SIDE UP VIEW (int. dimensions)

UPSIDE-DOWN VIEW (int. dimensions)

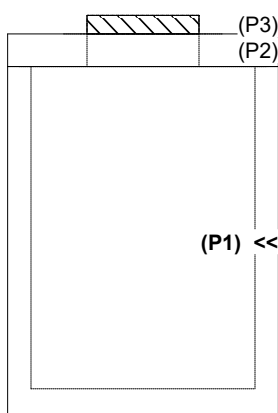
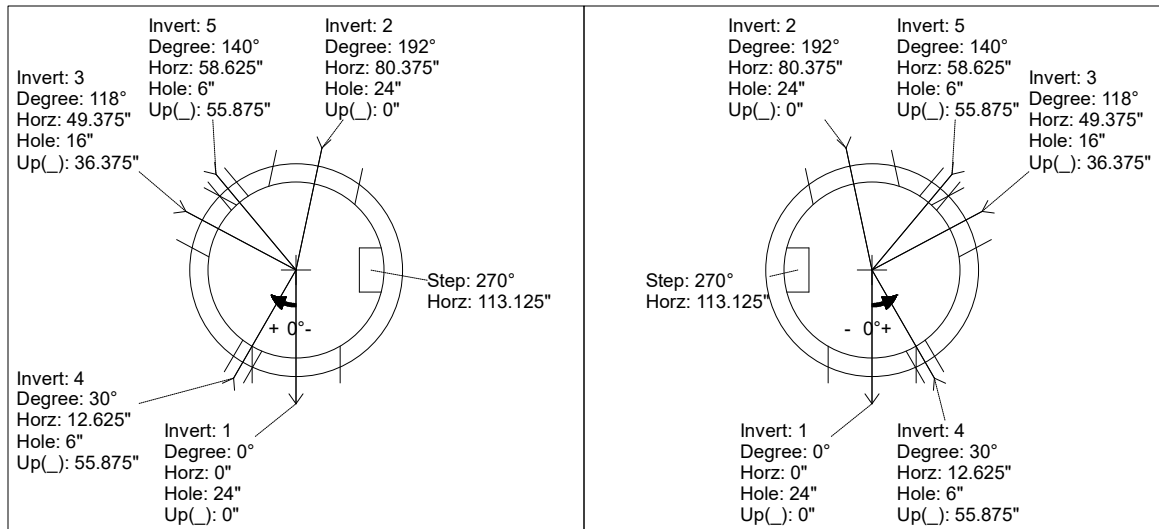

INSIDE WALL DIMENSIONS

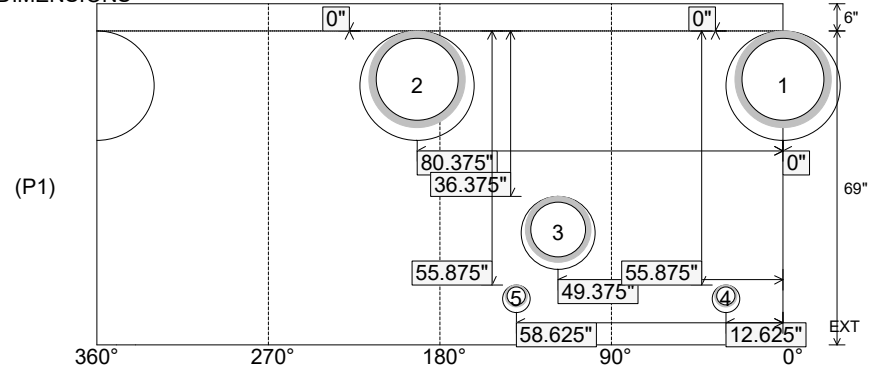

Coating (Int): Coating (Ext):	Seam Up: Flat Seam Dn: n/a	Wall Thickness: 5" Floor Height: 6"	Height (Int): 69" Height (Ext): 75"	Weight (Net): 5646 lb Volume (Net): 1.44cu.yd
----------------------------------	-------------------------------	--	--	--